

# **AGRO cable glands.** EMC cable glands for interference-free cable installations.

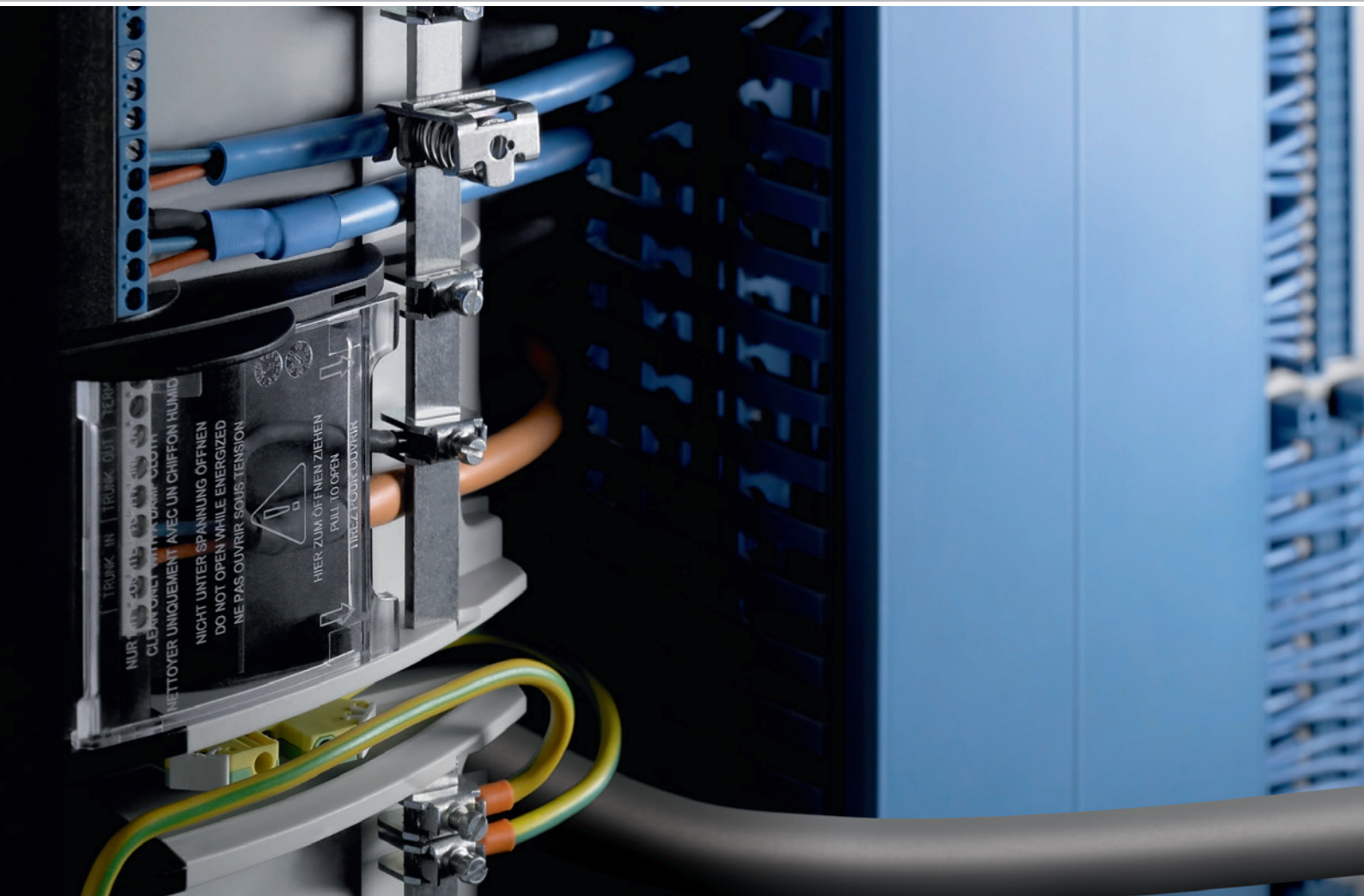



# EMC.

## A topic with serious consequences.

**Electromagnetic compatibility (EMC)** is something that everyone in our modern world is confronted with. For instance, if a bothersome tone in the radio alerts you that your mobile phone is ringing, this is a typical case of an electromagnetic interaction between two pieces of equipment.

In this context, disturbing noises are only the most harmless consequences of such unwanted interactions. When your expensive high-tech car won't move because of electromagnetic incompatibilities in the on-board computer, things become much more upsetting and expensive. This topic takes on a whole new meaning when the functions of entire industrial plants or medical devices are disrupted or even brought to a standstill because of EMC problems. The financial damages due to a manufacturing outage can quickly reach enormous amounts in the 5- to 7-digit Euro range – not to speak of possible loss of data or damage to the company's image arising from delayed deliveries.

**As our everyday lives and businesses tend to increasingly rely on technology**, the issue of EMC continually gains added importance. More and more electronic devices are being used in the home, industrial plants are becoming more complex, and it's hard to imagine life without new wireless technologies such as GPS, Bluetooth or WLANs. Just as the electronics industry is growing, so too is the level of electromagnetic interference because basically every piece of electrical equipment is susceptible to EMC and itself even creates such interference. Achieving 100 percent electromagnetic compatibility is the goal we want to achieve. In fact, it has become mandatory to address interference suppression / susceptibility to faults early in the planning and development phases of machines, systems and equipment and in doing so include all relevant components. In this way, expensive rework can be avoided. Specifically, statistics indicate that almost 40 percent of all electronic failures can be traced back to insufficient EMC measures.



Standards and regulations. EMC directives.	4
The most important things for interference-free operation. Shielding and contact.	5

	Requirements	Products	
<b>EMC cable glands</b>	Quick assembly.	<b>Progress® EMC Rapid Brass.</b>	6
	Quick, convenient installation.	<b>Progress® EMC easyCONNECT Brass.</b>	8
	Constant contact quality with low transfer impedance.	<b>Progress® EMC Brass.</b>	10
	Direct contact for high leakage currents, lowest transfer impedance.	<b>Progress® EMC powerCONNECT Brass.</b>	12
	For applications where high discharge values are needed.	<b>Progress® EMC Series 85 Brass.</b>	14
<b>Further products and accessories</b>	Enhanced requirements to EMC cable entry.	<b>Further EMC equipment.</b>	18
	Accessories for EMC cable entry.	<b>Accessories.</b>	18
	Technical overview.		19
	<b>AGRO</b> cable glands. Systems and solutions for professional cable entry.		20



# Standards and regulations.

## EMC directives.

**What, exactly, is EMC?** Every electrical device generates an electromagnetic field around itself, and this field in turn can induce currents and voltages in other electrical devices. Depending on the intensity of the mutual coupling, this effect can lead to malfunctions, reduced functionality or even total failure of the equipment.

**In European Standard EN 61000**, the term EMC is defined as follows: Electromagnetic compatibility is the ability of a piece of electrical equipment to function satisfactorily in an electromagnetic environment without influencing this same environment, in which other equipment is located, more than is permitted. The active and passive aspects of this definition can be more clearly illustrated with the example of a pacemaker. The operation of such a pacemaker should not in the least be compromised by environmental influences to ensure that the patient's life is not put in danger. On the other hand, the patient himself must not be harmed by the operation of the device itself.

**Basically, a distinction is drawn between electromagnetic influences in the low-frequency and high-frequency regions.** In the low-frequency region, interference arises due to the various forms of coupling (galvanic, inductive, capacitive) between two electrical circuits. In the high-

frequency region starting at 1 MHz and above, in contrast, there are additional field-related coupling effects that have an effect on susceptible equipment, which can act as a sink for the interference – in other words, on receivers, electrotechnical equipment or electrical systems. Furthermore, there is a distinction between natural sources of interference such as lightning and artificial causes such as TV and radio transmitters, frequency converters and switching operations.

**When it comes to EMC, not only technical issues are of interest but also legal aspects.** In general, electrical products, machines and systems are subject to various directives, laws, ordinances and regulations. The legal provisions applicable to EMC at the European level are intended to guarantee not only free movement of goods within the domestic markets but also to ensure the protection of health and safety for people as well as to protect the environment, radio operations and consumers. Therefore, within the EU, only those products can be brought to market which meet the protection regulations established in the EMC Directive (2014/30/EC). Accordingly, manufactures must design their products such that no unacceptable electromagnetic interference arises between two devices or systems, and this is to be verified with corresponding test procedures.

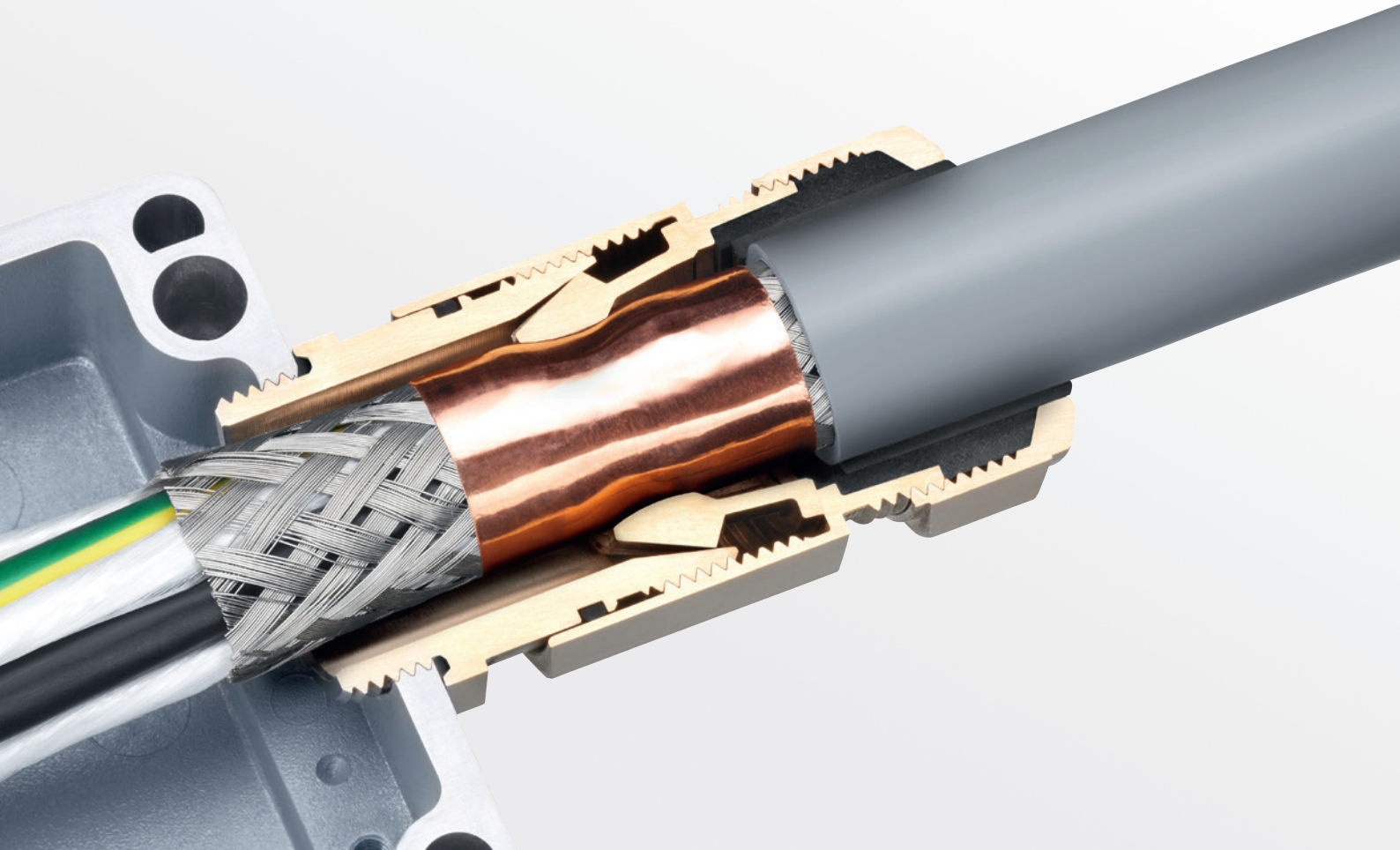

# The most important things for interference-free operation: Shielding and contact.

In the industrial sector, EMC plays a particularly key role because complex machines and systems are extremely susceptible to electromagnetic interference. Such undesired EMC effects, however, can be counteracted with the effective shielding of all components. On the one hand, good shielding reduces the amount of interference emitted by an electrical apparatus while at the same time reducing its susceptibility to impaired performance due to electromagnetic effects.

Not only cables themselves but also all other components that are part of the installation must provide shielding characteristics. Cable glands thus become active components and must ensure that the quality of the shielding at sensitive interconnection points remains intact and that there are no losses in shielding attenuation. For this reason, it's necessary to not only use a maximally shielded cable but also add EMC-compliant cable glands. Although there is no separate EMC standard for these components, they play a large contribution towards making it possible to meet the EMC characteristics prescribed by manufacturers.

**The effect of cable shielding depends on the shielding material, the type of shielding and the connection to electrical ground.** In order to achieve optimal effectiveness, the shielding should be connected to ground on both sides through a connection with both low resistivity and low

inductance. In other words, it must be led into the enclosure the shortest possible route and with a large contact surface. When subject to vibrations, a good contact must not result in an increased transfer resistance.

With five different EMC-compatible cable glands, AGRO offers its customers the appropriate product and the ideal types of contact for each type of application. With the new **Progress® EMC powerCONNECT Brass** cable gland (see pages 12/13), contact is established directly within the base part. Furthermore, AGRO offers the following proven series of products:

- **Progress® EMC Rapid Brass** (see pages 6/7)
- **Progress® EMC easyCONNECT Brass** (see pages 8/9)
- **Progress® EMC Brass** (see pages 10/11)
- **Progress® Series 85 Brass** (see pages 14/15)

**All these product lines stand out due to their easy assembly.** Furthermore, the renowned Swiss EMC laboratory MONTENA EMC SA has certified AGRO cable glands for lowest transfer impedance and high current carrying capacity. Both are established criteria for the quality of shielding. In order to achieve the best possible results, AGRO involves EMC specialists right from the start in the development of new products.

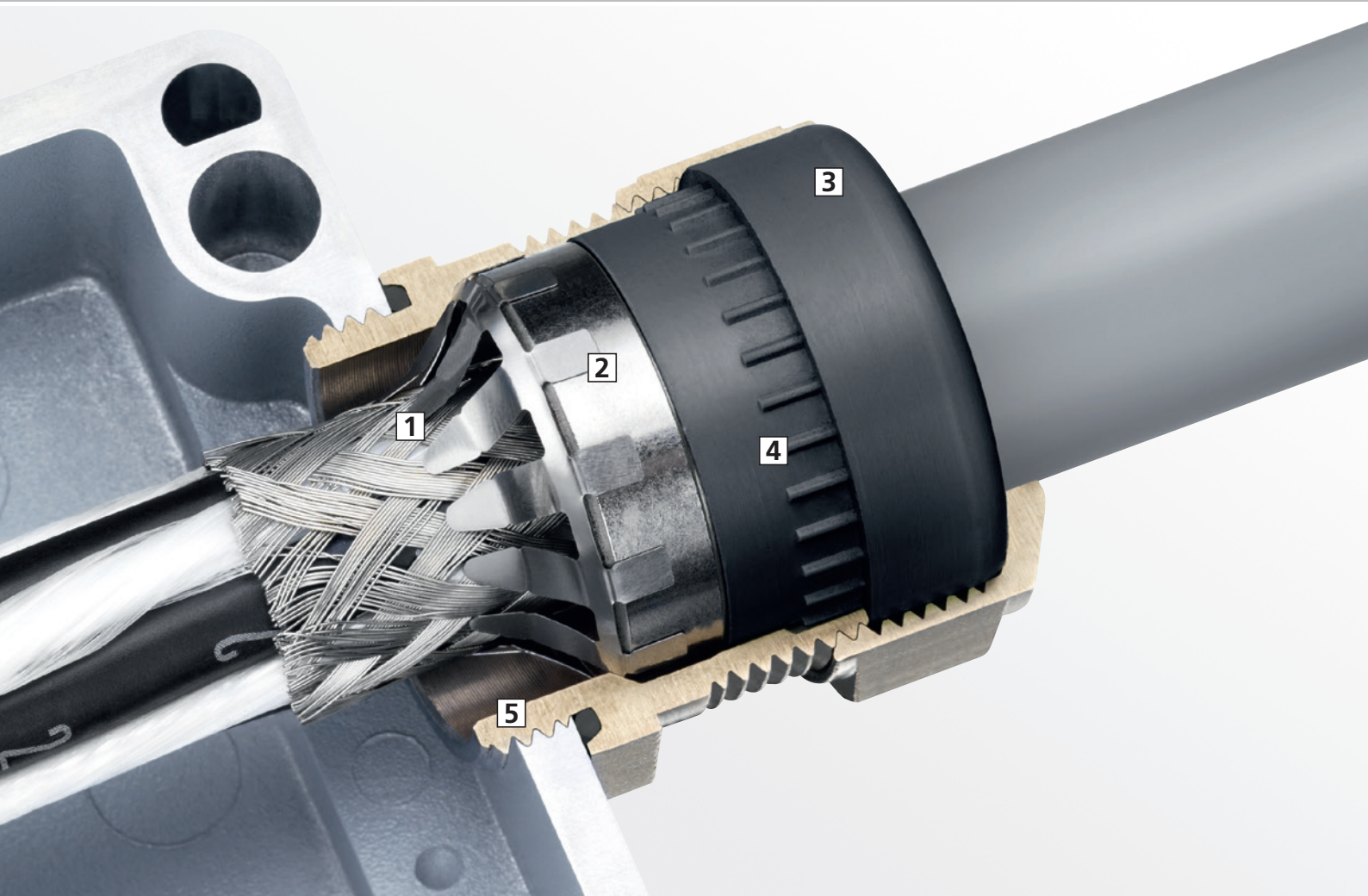

# Progress® EMC Rapid.

## For quick assembly.



The cable gland with two contact options. An integrated contact disc allows for easy and fast contact to the shield of partially stripped cables as well as of fully stripped cables which shields are being extended.

### 1 Low contact resistance

The flexible tongues on the contact disc, with their large surface area, maximise the gripping surface on the braided shield.

### 2 Flexible terminating methods

If a 360° contact is required, the contact disc can be extruded and the trimmed shield can be connected to the contact bushing.

### 2 Continuous contract pressure

The interlocking "sealing insert/contact sleeve" combination ensures that the contact washer continually presses on the bottom part.

### 3 Perfect sealing

Inner contours matched to the sealing insert ensure a targeted deformation of the insert and thus guarantee its tightness in compliance with protection class IP 68 / IP 69K / NEMA 4X.

### 4 High resistance to torsion

The integrated retaining grooves in the lower part and in the sealing insert grant against twisting.

### 5 Metric or PG entry threads

Progress® EMC Rapid cable glands are available with long or short entry threads metric or PG and can be screwed into existing threaded openings or be fixed with an EMC locknut.



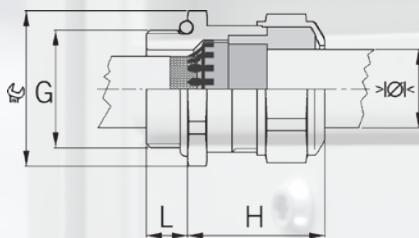
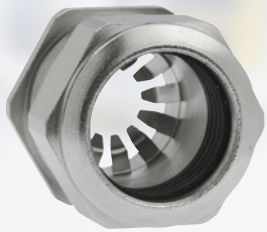

**Material:** Nickel-plated brass  
**Contact sleeve:** Nickel-plated brass  
**Contact washer:** Stainless steel A2  
**Seals:** TPE  
**O-ring:** NBR  
**Strain relief:** Version A acc. to EN 62444  
**Temperature range:** -40°C / +100°C  
**Protection class:** IP 68 (up to) / IP 69K / NEMA 4X

Short entry thread metric							
G	>Ø< min mm	>Ø< max mm	mm	H mm	L mm	Art.-No.	
M12x1.5	4.5	6.0	15	20	5	1081.12.060	50
M12x1.5	6.0	7.5	15	20	5	1081.12.075	50
M16x1.5	6.0	8.0	18	23	5	1081.17.080	50
M16x1.5	8.0	10.0	18	25	5	1081.17.100	50
M20x1.5	8.0	11.0	24	25	6	1081.20.110	50
M20x1.5	11.0	14.0	24	27	6	1081.20.140	50
M25x1.5	13.0	16.0	30	30	7	1081.25.160	25
M25x1.5	16.0	19.0	30	33	7	1081.25.190	25
M32x1.5	18.0	21.0	36	32	8	1081.32.210	25
M32x1.5	21.0	25.0	36	32	8	1081.32.250	25

Long entry thread metric							
G	>Ø< min mm	>Ø< max mm	mm	H mm	L mm	Art.-No.	
M12x1.5	4.5	6.0	15	20	10	1181.12.060	50
M12x1.5	6.0	7.5	15	20	10	1181.12.075	50
M16x1.5	6.0	8.0	18	23	10	1181.17.080	50
M16x1.5	8.0	10.0	18	25	10	1181.17.100	50
M20x1.5	8.0	11.0	24	25	10	1181.20.110	50
M20x1.5	11.0	14.0	24	27	10	1181.20.140	50
M25x1.5	13.0	16.0	30	30	11	1181.25.160	25
M25x1.5	16.0	19.0	30	33	11	1181.25.190	25
M32x1.5	18.0	21.0	36	32	13	1181.32.210	25
M32x1.5	21.0	25.0	36	32	13	1181.32.250	25

Short entry thread Pg							
G	>Ø< min mm	>Ø< max mm	mm	H mm	L mm	Art.-No.	
Pg 7	4.5	6.0	15	20	6	1081.07.060	50
Pg 7	6.0	7.5	15	20	6	1081.07.075	50
Pg 9	6.0	8.0	18	23	6	1081.09.080	50
Pg 9	8.0	10.0	18	25	6	1081.09.100	50
Pg 11	5.5	8.5	21	25	6	1081.11.085	50
Pg 11	8.5	12.0	21	25	6	1081.11.120	50
Pg 13	8.0	11.0	24	25	6	1081.13.110	50
Pg 13	11.0	14.0	24	27	6	1081.13.140	50
Pg 16	8.0	11.0	24	24	6	1081.16.110	50
Pg 16	11.0	14.0	24	27	6	1081.16.140	50
Pg 21	13.0	16.0	30	30	7	1081.21.160	25
Pg 21	16.0	19.0	30	33	7	1081.21.190	25
Pg 29	19.0	23.0	38	33	8	1081.29.230	25
Pg 29	23.0	25.5	38	32	8	1081.29.255	25

Long Entry thread Pg							
G	>Ø< min mm	>Ø< max mm	mm	H mm	L mm	Art.-No.	
Pg 7	4.5	6.0	15	20	10	1181.07.060	50
Pg 7	6.0	7.5	15	20	10	1181.07.075	50
Pg 9	6.0	8.0	18	23	10	1181.09.080	50
Pg 9	8.0	10.0	18	25	10	1181.09.100	50
Pg 11	5.5	8.5	21	25	10	1181.11.085	50
Pg 11	8.5	12.0	21	25	10	1181.11.120	50
Pg 13	8.0	11.0	24	25	10	1181.13.110	50
Pg 13	11.0	14.0	24	27	10	1181.13.140	50
Pg 16	8.0	11.0	24	24	10	1181.16.110	50
Pg 16	11.0	14.0	24	27	10	1181.16.140	50
Pg 21	13.0	16.0	30	30	12	1181.21.160	25
Pg 21	16.0	19.0	30	33	12	1181.21.190	25
Pg 29	19.0	23.0	38	33	12	1181.29.230	25
Pg 29	23.0	25.5	38	32	12	1181.29.255	25

Model for Ex applications available.  
 SEV approval for metric threads only.

Technical details are subject to change.

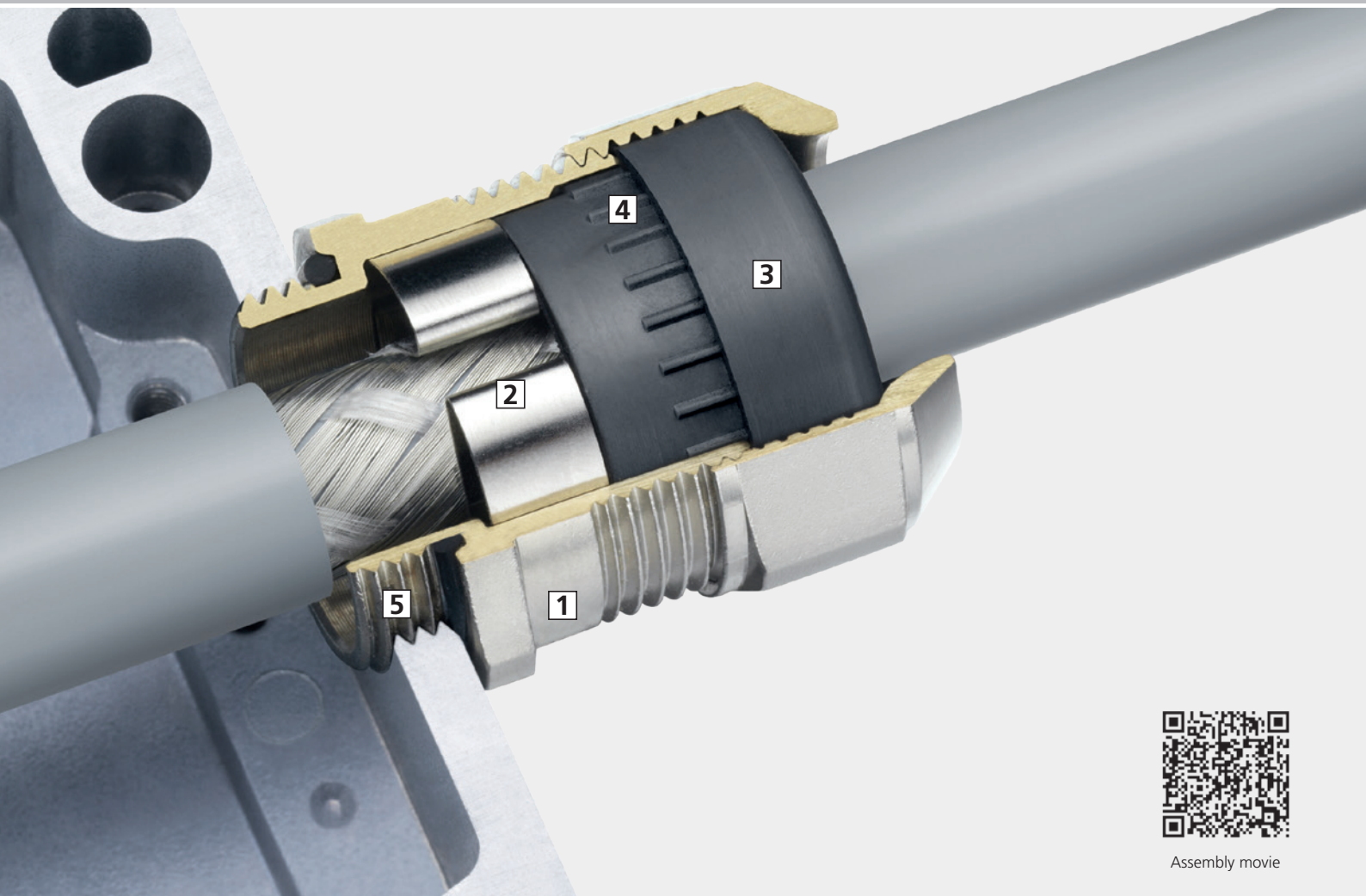

Assembly movie

# Progress® EMC easyCONNECT.

## Quick, convenient installation thanks to an innovative contact spring.



The cable glands Progress® EMC easyCONNECT guarantees full control during installation and compensates for tolerances in shielding thicknesses to make a secure screened tap connection. The spring system provides for a very good contact of partially stripped shielding cables equally as well as for the contact of completely exposed cable shields which can be routed further.

### 1 Immediately recognisable

Thanks to the marking on the bottom section, the Progress® EMC easyCONNECT can be immediately identified by its EMC imprinting all around.

### 2 Optimal shield contact

The powerful, protective clamping of the cable shield guarantees excellent shield contact and provides for small transfer impedance. The shape of the contact spring not only allows for a large clamping range to the shield nut also for easy disassembly without damaging the cable braid.

### 3 Best possible sealing

Two-part sealing inserts can be adapted to the existing cable diameter on site in just seconds and guarantee perfect sealing in compliance with IP 68 and IP 69K / NEMA 4X.

### 4 High resistance to torsion

The integrated retaining grooves in the lower part and in the sealing insert grant against twisting.

### 5 Short or long entry threads

Short or long entry threads in metric or PG types allow secure anchoring of the cable gland with or without an EMC locknut.

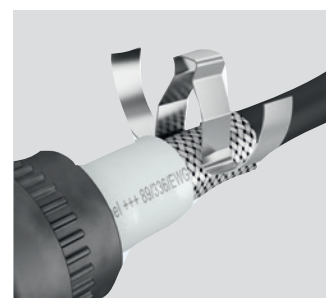
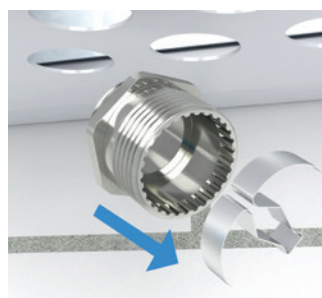



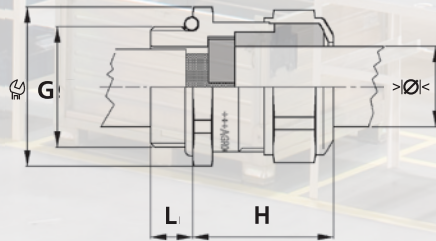

**Material:** Nickel-plated brass  
**Contact spring:** Spring steel 1.4310  
**Seals:** TPE  
**O-ring:** NBR  
**Strain relief:** Version A acc. to EN 62444  
**Temperature range:** -60°C / +100°C  
**Protection class:** IP 68 (up to 10 bar) / IP 69K

### Short entry thread metric

Two-piece sealing insert  
not overall length insulated

G	>Ø< min mm	>Ø< max mm	>Ø< min mm	>Ø< max mm	mm	H mm	L mm	i info	Art.No.	
M12x1.5	-	-	3.5	5.0	15	22	5	1	1083.12.050	50
M12x1.5	-	-	5.0	6.5	15	22	5	1	1083.12.065	50
M16x1.5	6.0	8.0	8.0	10.5	18	25	5	-	1083.17	50
M20x1.5	8.0	11.0	11.0	15.0	24	27	6	-	1083.20	50
M25x1.5	12.5	16.0	16.0	20.5	30	33	7	-	1083.25	25
M32x1.5	17.0	21.0	21.0	25.5	36	33	8	-	1083.32	25
M40x1.5	24.0	28.5	28.5	33.0	46	38	8	-	1083.40	10
M50x1.5	33.0	37.0	37.0	42.0	55	42	9	-	1083.50	10
M63x1.5	40.0	46.0	46.0	52.0	70	42	10	-	1083.63	5

### Long entry thread metric

Two-piece sealing insert  
not overall length insulated

G	>Ø< min mm	>Ø< max mm	>Ø< min mm	>Ø< max mm	mm	H mm	L mm	i info	Art.No.	
M12x1.5	-	-	3.5	5.0	15	22	10	1	1183.12.050	50
M12x1.5	-	-	5.0	6.5	15	22	10	1	1183.12.065	50
M16x1.5	6.0	8.0	8.0	10.5	18	25	10	-	1183.17	50
M20x1.5	8.0	11.0	11.0	15.0	24	27	10	-	1183.20	50
M25x1.5	12.5	16.0	16.0	20.5	30	33	11	-	1183.25	25
M32x1.5	17.0	21.0	21.0	25.5	36	33	13	-	1183.32	25
M40x1.5	24.0	28.5	28.5	33.0	46	38	13	-	1183.40	10
M50x1.5	33.0	37.0	37.0	42.0	55	42	14	-	1183.50	10
M63x1.5	40.0	46.0	46.0	52.0	70	42	14	-	1183.63	5

1 = One piece sealing insert

**Available on request:**

- With sealing inserts in conformity with EN 45545. When placing an order or an inquiry, prefix the article number by the capital F.
- Stainless steel A2 and A4
- PG and NPT entry threads

Technical details are subject to change.

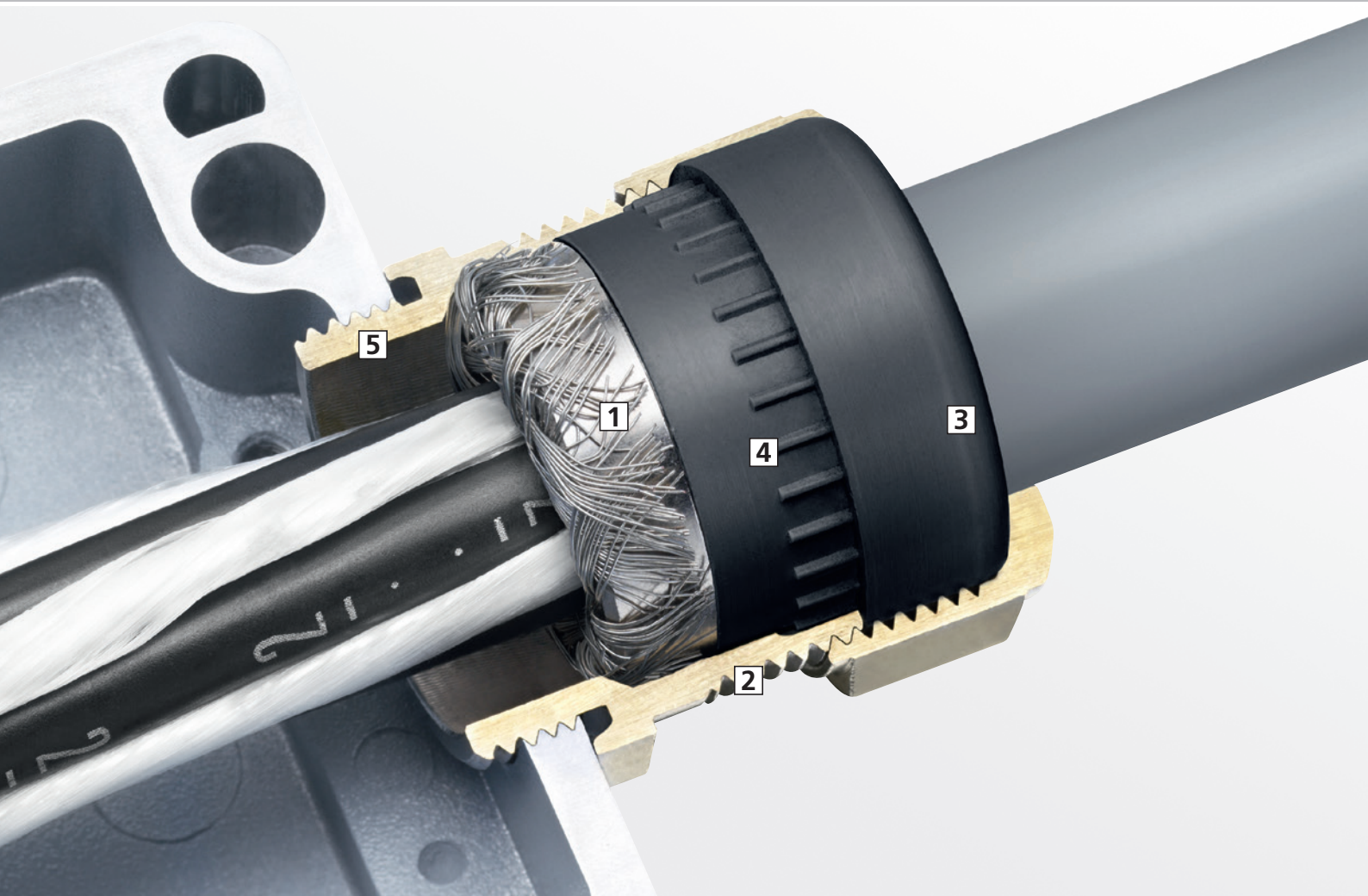

# Progress® EMC.

## Constant contact quality with low transfer impedance.



**Progress® EMC cable glands made of brass and with the time-proven contact sleeve** make 360° contact with braided shield which terminates at the cable gland. The decisive edge geometry of the contact sleeve prevents any shearing of the braided shield.

### 1 Low contact resistance

The immense 360° contact surface ensures low contact resistance.

### 2 Permanent contact pressure

The interlocking "sealing insert/contact sleeve" combination ensures permanent contact pressure of the braided shield against the lower part.

### 3 Optimal sealing and high temperature stability

Inner contours matched to the sealing insert ensure a targeted deformation of the insert and thus guarantee its tightness in compliance with protection class IP 68 / IP 69K. For applications at +200°C, FPM sealing inserts are available.

### 4 High resistance to torsion

The integrated retaining grooves in the lower part and in the sealing insert grant against twisting.

### 5 Short or long entry threads

Short or long entry threads in metric or PG types allow secure anchoring of the cable gland with or without an EMC locknut.

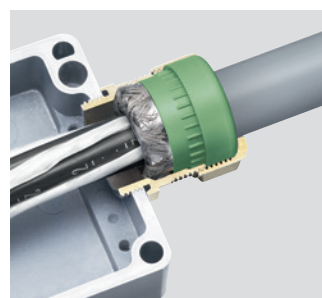

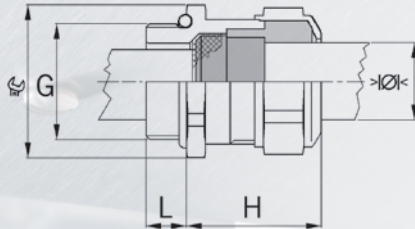

**Material:** Nickel-plated brass  
**Contact sleeve:** Nickel-plated brass  
**Seals:** TPE  
**O-ring:** NBR  
**Strain relief:** Version A acc. to EN 62444  
**Temperature range:** -40°C / +100°C  
**Protection class:** IP 68 (up to 10 bar) / IP 69K

Short entry thread metric							
G	>Ø< min mm	>Ø< max mm	mm	H mm	L mm	Art.-No.	
M8x1.25 <sup>1)</sup>	2.5	3.5	11	14	5	1080.08.035	50
M8x1.25 <sup>1)</sup>	3.0	4.0	11	14	5	1080.08.040	50
M10x1.5 <sup>1)</sup>	3.0	4.0	13	15	5	1080.10.040	50
M10x1.5 <sup>1)</sup>	4.0	6.0	13	15	5	1080.10.060	50
M12x1.5	4.5	6.0	15	17	5	1080.12.060	50
M12x1.5	6.0	7.5	15	17	5	1080.12.075	50
M16x1.5	6.0	8.0	18	20	5	1080.17.080	50
M16x1.5	8.0	10.0	18	22	5	1080.17.100	50
M20x1.5	8.0	11.0	24	21	6	1080.20.110	50
M20x1.5	11.0	14.0	24	23	6	1080.20.140	50
M25x1.5	13.0	16.0	30	25	7	1080.25.160	25
M25x1.5	16.0	19.0	30	28	7	1080.25.190	25
M32x1.5	18.0	21.0	36	29	8	1080.32.210	25
M32x1.5	21.0	25.0	36	29	8	1080.32.250	25
M40x1.5	24.0	28.5	46	31	8	1080.40.285	10
M40x1.5	28.5	32.0	46	31	8	1080.40.320	10
M50x1.5	33.0	37.0	55	34	9	1080.50.370	10
M50x1.5	37.0	41.0	55	34	9	1080.50.410	10
M63x1.5	40.0	46.0	70	37	10	1080.63.460	5
M63x1.5	46.0	50.0	70	37	10	1080.63.500	5
M75x1.5	50.0	56.0	80	40	11	1080.75.560	1
M80x2.0	56.0	65.0	95	45	18	1080.80.650	1
M85x2.0	63.0	70.0	95	45	18	1080.85.700	1
M95x2.0	68.0	75.0	110	52	20	1080.95.750	1

1) Metric coarse-pitch thread

Long entry thread metric							
G	>Ø< min mm	>Ø< max mm	mm	H mm	L mm	Art.-No.	
M8x1.25 <sup>1)</sup>	2.5	3.5	11	14	10	1180.08.035	50
M8x1.25 <sup>1)</sup>	3.0	4.0	11	14	10	1180.08.040	50
M10x1.5 <sup>1)</sup>	3.0	4.0	13	15	10	1180.10.040	50
M10x1.5 <sup>1)</sup>	4.0	6.0	13	15	10	1180.10.060	50
M12x1.5	4.5	6.0	15	17	10	1180.12.060	50
M12x1.5	6.0	7.5	15	17	10	1180.12.075	50
M16x1.5	6.0	8.0	18	20	10	1180.17.080	50
M16x1.5	8.0	10.0	18	22	10	1180.17.100	50
M20x1.5	8.0	11.0	24	21	10	1180.20.110	50
M20x1.5	11.0	14.0	24	23	10	1180.20.140	50
M25x1.5	13.0	16.0	30	25	11	1180.25.160	25
M25x1.5	16.0	19.0	30	28	11	1180.25.190	25
M32x1.5	18.0	21.0	36	29	13	1180.32.210	25
M32x1.5	21.0	25.0	36	29	13	1180.32.250	25
M40x1.5	24.0	28.5	46	31	13	1180.40.285	10
M40x1.5	28.5	32.0	46	31	13	1180.40.320	10
M50x1.5	33.0	37.0	55	34	14	1180.50.370	10
M50x1.5	37.0	41.0	55	34	14	1180.50.410	10
M63x1.5	40.0	46.0	70	37	14	1180.63.460	5
M63x1.5	46.0	50.0	70	37	14	1180.63.500	5

1) Metric coarse-pitch thread  
 Executions for Ex applications available.  
 SEV approval for metric threads only.

Short entry thread Pg							
G	>Ø< min mm	>Ø< max mm	mm	H mm	L mm	Art.-No.	
Pg 7	4.5	6.0	15	17	6	1080.07.060	50
Pg 7	6.0	7.5	15	17	6	1080.07.075	50
Pg 9	6.0	8.0	18	20	6	1080.09.080	50
Pg 9	8.0	10.0	18	22	6	1080.09.100	50
Pg 11	5.5	8.5	21	21	6	1080.11.085	50
Pg 11	8.5	12.0	21	21	6	1080.11.120	50
Pg 13	8.0	11.0	24	21	6	1080.13.110	50
Pg 13	11.0	14.0	24	23	6	1080.13.140	50
Pg 16	8.0	11.0	24	21	6	1080.16.110	50
Pg 16	11.0	14.0	24	23	6	1080.16.140	50
Pg 21	13.0	16.0	30	25	7.5	1080.21.160	25
Pg 21	16.0	19.0	30	28	7.5	1080.21.190	25
Pg 29	19.0	23.0	38	29	8	1080.29.230	25
Pg 29	23.0	25.5	38	29	8	1080.29.255	25
Pg 36	25.0	30.5	50	32	8	1080.36.305	10
Pg 36	30.5	35.0	50	32	8	1080.36.350	10
Pg 42	33.0	37.0	55	34	10	1080.42.370	10
Pg 42	37.0	41.0	55	34	10	1080.42.410	10
Pg 48	39.0	43.0	65	37	11	1080.48.430	10
Pg 48	43.0	46.5	65	37	11	1080.48.465	10

Long entry thread Pg							
G	>Ø< min mm	>Ø< max mm	mm	H mm	L mm	Art.-No.	
Pg 7	4.5	6.0	15	17	10	1180.07.060	50
Pg 7	6.0	7.5	15	17	10	1180.07.075	50
Pg 9	6.0	8.0	18	20	10	1180.09.080	50
Pg 9	8.0	10.0	18	22	10	1180.09.100	50
Pg 11	5.5	8.5	21	21	10	1180.11.085	50
Pg 11	8.5	12.0	21	21	10	1180.11.120	50
Pg 13	8.0	11.0	24	21	10	1180.13.110	50
Pg 13	11.0	14.0	24	23	10	1180.13.140	50
Pg 16	8.0	11.0	24	21	10	1180.16.110	50
Pg 16	11.0	14.0	24	23	10	1180.16.140	50
Pg 21	13.0	16.0	30	25	12	1180.21.160	25
Pg 21	16.0	19.0	30	28	12	1180.21.190	25
Pg 29	19.0	23.0	38	29	12	1180.29.230	25
Pg 29	23.0	25.5	38	29	12	1180.29.255	25
Pg 36	25.0	30.5	50	32	15	1180.36.305	10
Pg 36	30.5	35.0	50	32	15	1180.36.350	10
Pg 42	33.0	37.0	55	34	15	1180.42.370	10
Pg 42	37.0	41.0	55	34	15	1180.42.410	10
Pg 48	39.0	43.0	65	37	15	1180.48.430	10
Pg 48	43.0	46.5	65	37	15	1180.48.465	10

**Available on request:**

- FPM Sealing insert for high temperatures.
  - With sealing inserts in conformity with EN 45545 / NFPA130. When placing an order or an inquiry, prefix the article number by the capital F.
- Technical details are subject to change.

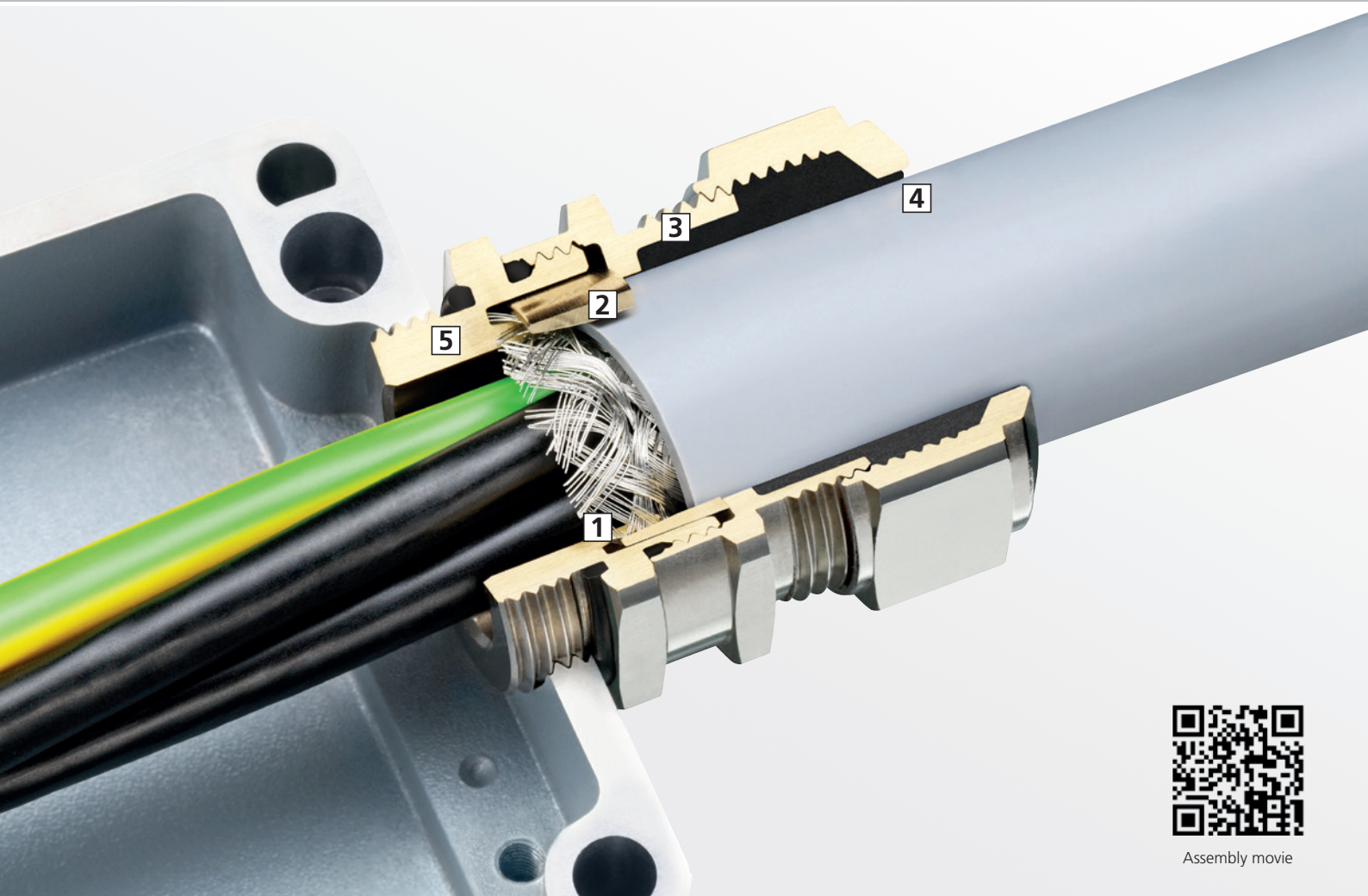

Assembly movie

# Progress® EMC powerCONNECT.

## Direct connection for high leakage currents.

**Progress® EMC powerCONNECT**, with its new, advanced compression sleeve, ensures reliable 360° shield contact in a very compact unit. This method of shield contacting has been used for many years in communications engineering and is now also available in industry. The direct transfer from the shielding to the cable gland's lower part ensures extremely low transfer resistance.

### 1 Lowest transfer resistance

As a result of the direct contact between the cable's shielding and the cable gland's cone, transfer resistance is extremely low and the transfer impedance of the system is reduced.

### 2 High leakage currents

Lasting high contact pressure, which results from the fixed compression sleeve and the complete tightening of the middle piece, maximises grounding of leakage currents, the extent of which is limited only by the shield's cross-sectional area.

### 3 Special middle piece

The complete tightening of the middle piece clamps the shield braid properly without mechanically loading the cable's electricity-transmitting wires.

### 4 High flexibility

Excellent sealing performance with high flexibility. The two-part sealing inserts facilitate a large spectrum in the clamping range at a particular protection class (IP 68 / IP 69K / NEMA 4X).

### 5 Diverse entry threads

Progress® EMC powerCONNECT cable glands can be supplied with short or long entry threads. Metric threads facilitate installation in threaded holes or with EMC locknuts.



M	min. L mm
M16	≥ 13
M20	≥ 14
M25	≥ 15
M32	≥ 17
M40	≥ 18
M50/63	≥ 20
M75/80/85	≥ 22

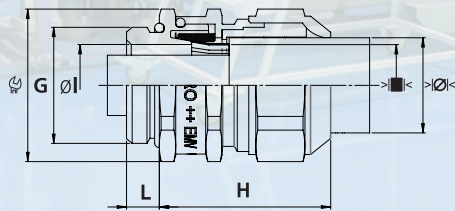

**Material:** Nickel-plated brass  
**Seals:** TPE  
**O-ring:** NBR  
**Strain relief:** Version A acc. to EN 62444  
**Temperature range:** -60°C / +100°C  
**Protection class:** IP 68 (up to 10 bar) / IP 69K / NEMA 4X

**Short entry thread metric**

G	$\gt;\text{Ø}\text{<}$ min mm	$\gt;\text{Ø}\text{<}$ max mm	$\gt;\text{Ø}\text{<}$ min mm	$\gt;\text{Ø}\text{<}$ max mm	$\gt;\blacksquare\text{<}$ max mm	ØI mm	$\text{⌀}$ mm	H mm	L mm	i info	Art.-No.	
M16x1.5	6.0	8.0	8.0	10.5	9.3	8.2	18	28	5	-	1084.17	25
M20x1.5	8.0	11.0	11.0	15.0	13.4	11.9	24	32	6	-	1084.20	25
M25x1.5	12.5	16.0	16.0	20.5	18.7	17.9	30	36.5	7	-	1084.25	25
M32x1.5	17.0	21.0	21.0	25.5	23.8	22.1	36	39	8	-	1084.32	25
M40x1.5	24.0	28.5	28.5	33.0	30.4	29.5	46	42	8	-	1084.40	10
M50x1.5	33.0	37.0	37.0	42.0	38.7	37.7	55	44.5	9	-	1084.50	10
M63x1.5	40.0	46.0	46.0	52.0	48.6	46.6	70	49	10	-	1084.63	5
M75x1.5	50.0	56.0	56.0	63.0	59.7	57.9	80	51	11	-	1084.75	1
M80x2.0	-	-	58.0	65.0	62.0	59.8	95	58	12	1	1084.80.650	1
M85x2.0	-	-	63.0	75.0	67.0	64.7	95	58	12	1	1084.85.700	1

**Long entry thread metric**

G	$\gt;\text{Ø}\text{<}$ min mm	$\gt;\text{Ø}\text{<}$ max mm	$\gt;\text{Ø}\text{<}$ min mm	$\gt;\text{Ø}\text{<}$ max mm	$\gt;\blacksquare\text{<}$ max mm	ØI mm	$\text{⌀}$ mm	H mm	L mm	i info	Art.-No.	
M16x1.5	6.0	8.0	8.0	10.5	9.3	8.2	18	28	10	-	1184.17	25
M20x1.5	8.0	11.0	11.0	15.0	13.4	11.9	24	32	10	-	1184.20	25
M25x1.5	12.5	16.0	16.0	20.5	18.7	17.6	30	36.5	11	-	1184.25	25
M32x1.5	17.0	21.0	21.0	25.5	23.8	22.1	36	39	13	-	1184.32	25
M40x1.5	24.0	28.5	28.5	33.0	30.4	29.5	46	42	13	-	1184.40	10
M50x1.5	33.0	37.0	37.0	42.0	38.7	37.7	55	44.5	14	-	1184.50	10
M63x1.5	40.0	46.0	46.0	52.0	48.6	46.6	70	49	14	-	1184.63	5
M75x1.5	50.0	56.0	56.0	63.0	59.7	57.9	80	51	15	-	1184.75	1
M80x2.0	-	-	58.0	65.0	62.0	59.8	95	58	18	1	1184.80.650	1
M85x2.0	-	-	63.0	70.0	67.0	64.7	95	58	18	1	1184.85.700	1

- 1 = One piece sealing insert
- $\gt;\text{Ø}\text{<}$  = maximum shield diameter
- $\text{⌀I}$  = maximum diameter of lower gland part

**Available on request:**

- With sealing inserts in conformity with EN 45545 / NFPA130. When placing an order or an inquiry, prefix the article number by the capital F.
- Stainless steel A2 and A4
- PG and NPT entry threads

Technical details are subject to change.



# Progress® EMC Series 85.

## Concentric screened tap connection for high leakage currents.



**Cable glands Progress® EMC Series 85** made of brass provide an especially low-impedance connection between the braided shield and the metal housing and a safe cable routing.

### 5 Metric or PG entry threads

Progress® EMC Series 85 cable glands with metric or PG entry threads can be screwed into existing threaded openings or be used with EMC locknuts.

### 1 Optimal shield contact

The connector piece, which is secured with the help of large wrenching surfaces, enables perfect contact of the braided shield by means of a collet chuck with segments that slide together around 360°. The copper tap grants equal transmission of the compression power.

### 2 Highest leakage currents

The massive collet guarantees a concentric, low-impedance screened tap connection and handles leakage currents of up to 1,600 A continuous – and short term to 3 kA.

### 3 Great flexibility

Two-part sealing inserts can be adapted to the existing cable diameter on site in just seconds.

### 4 Perfect sealing

Inner contours matched to the sealing insert ensure a targeted deformation of the insert and thus guarantee its tightness in compliance with protection class IP 68 / IP 69 / NEMA 4X.



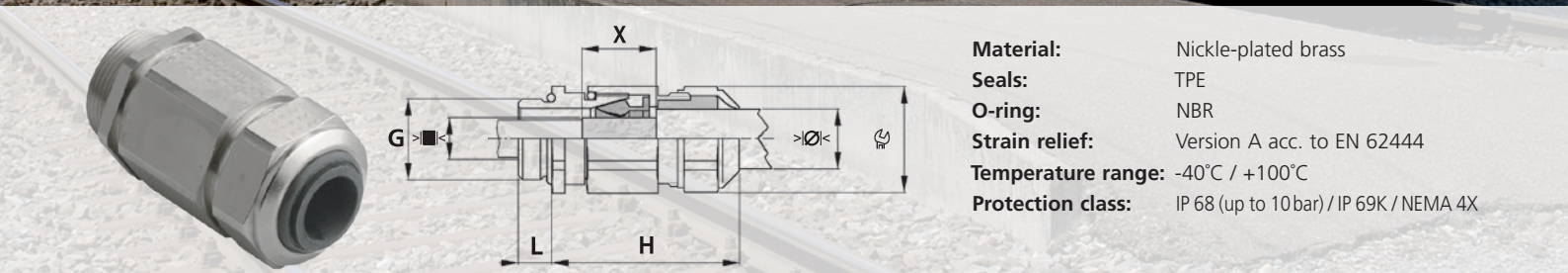

**Material:** Nickel-plated brass  
**Seals:** TPE  
**O-ring:** NBR  
**Strain relief:** Version A acc. to EN 62444  
**Temperature range:** -40°C / +100°C  
**Protection class:** IP 68 (up to 10 bar) / IP 69K / NEMA 4X

Entry thread metric											
G	$\begin{matrix} \text{>}\varnothing\text{<} \\ \text{min mm} \end{matrix}$	$\begin{matrix} \text{>}\varnothing\text{<} \\ \text{max mm} \end{matrix}$	$\begin{matrix} \text{>}\varnothing\text{<} \\ \text{min mm} \end{matrix}$	$\begin{matrix} \text{>}\varnothing\text{<} \\ \text{max mm} \end{matrix}$	$\begin{matrix} \text{>}\blacksquare\text{<} \\ \text{max mm} \end{matrix}$	$\begin{matrix} \varnothing \\ \text{mm} \end{matrix}$	H	L	X	Art.-No.	
M16x1.5	-	-	4.5	6.0	3.0-4.5	18	40	6	14	1000.17.85.045	25
M16x1.5	6.0	8.0	8.0	10.5	4.5-8.0	18	42	8	16	1000.17.85.080	25
M16x1.5	8.0	11.0	11.0	15.0	7.5-10.0	24	47	8	20	1000.17.85.100	25
M20x1.5	8.0	11.0	11.0	15.0	7.5-12.0	24	47	8	20	1000.20.85.120	25
M20x1.5	12.5	16.0	16.0	20.5	10.0-14.0	30	59	8	21	1000.20.85.140	20
M25x1.5	12.5	16.0	16.0	20.5	10.0-16.0	30	59	8	21	1000.25.85.160	20
M25x1.5	17.0	21.0	21.0	25.5	14.0-19.0	36	66	8	24	1000.25.85.190	25
M32x1.5	17.0	21.0	21.0	25.5	14.0-22.0	36	66	10	24	1000.32.85.220	25
M32x1.5	24.0	28.5	28.5	33.0	21.0-25.0	46	68	10	24	1000.32.85.250	5
M40x1.5	24.0	28.5	28.5	33.0	21.0-30.0	46	68	12	24	1000.40.85.300	5
M50x1.5	33.0	37.0	37.0	42.0	29.0-38.0	55	77	13	25	1000.50.85.380	5
M63x1.5	33.0	37.0	37.0	42.0	29.0-38.0	70/55	77	15	25	1000.63.85.380	5
M63x1.5	40.0	46.0	46.0	52.0	35.0-44.0	70	78	15	26	1000.63.85.440	1

Entry thread metric Pg											
G	$\begin{matrix} \text{>}\varnothing\text{<} \\ \text{min mm} \end{matrix}$	$\begin{matrix} \text{>}\varnothing\text{<} \\ \text{max mm} \end{matrix}$	$\begin{matrix} \text{>}\varnothing\text{<} \\ \text{min mm} \end{matrix}$	$\begin{matrix} \text{>}\varnothing\text{<} \\ \text{max mm} \end{matrix}$	$\begin{matrix} \text{>}\blacksquare\text{<} \\ \text{max mm} \end{matrix}$	$\begin{matrix} \varnothing \\ \text{mm} \end{matrix}$	H	L	X	Art.-No.	
Pg 11	6.0	8.0	8.0	10.5	4.5-8.0	21/18	42	8	16	1000.11.85.080	25
Pg 11	8.0	11.0	11.0	15.0	7.5-12.0	24	47	8	20	1000.11.85.120	25
Pg 16	8.0	11.0	11.0	15.0	7.5-12.0	24	47	8	20	1000.16.85.120	25
Pg 16	12.5	16.0	16.0	20.5	10.0-15.0	30	59	8	21	1000.16.85.150	25
Pg 21	12.5	16.0	16.0	20.5	10.0-16.0	30	59	8	21	1000.21.85.160	20
Pg 21	17.0	21.0	21.0	25.5	14.0-19.0	36	66	8	24	1000.21.85.190	25
Pg 29	17.0	21.0	21.0	25.5	14.0-22.0	38/36	66	10	24	1000.29.85.220	20
Pg 29	24.0	28.5	28.5	33.0	21.0-25.0	46	68	10	24	1000.29.85.250	5

$\begin{matrix} \text{>}\blacksquare\text{<} \\ \text{max mm} \end{matrix}$  = maximum shield diameter

**Available on request:**

· With sealing inserts in conformity with EN 45545 / NFPA130. When placing an order or an inquiry, prefix the article number by the capital F.

Technical details are subject to change.

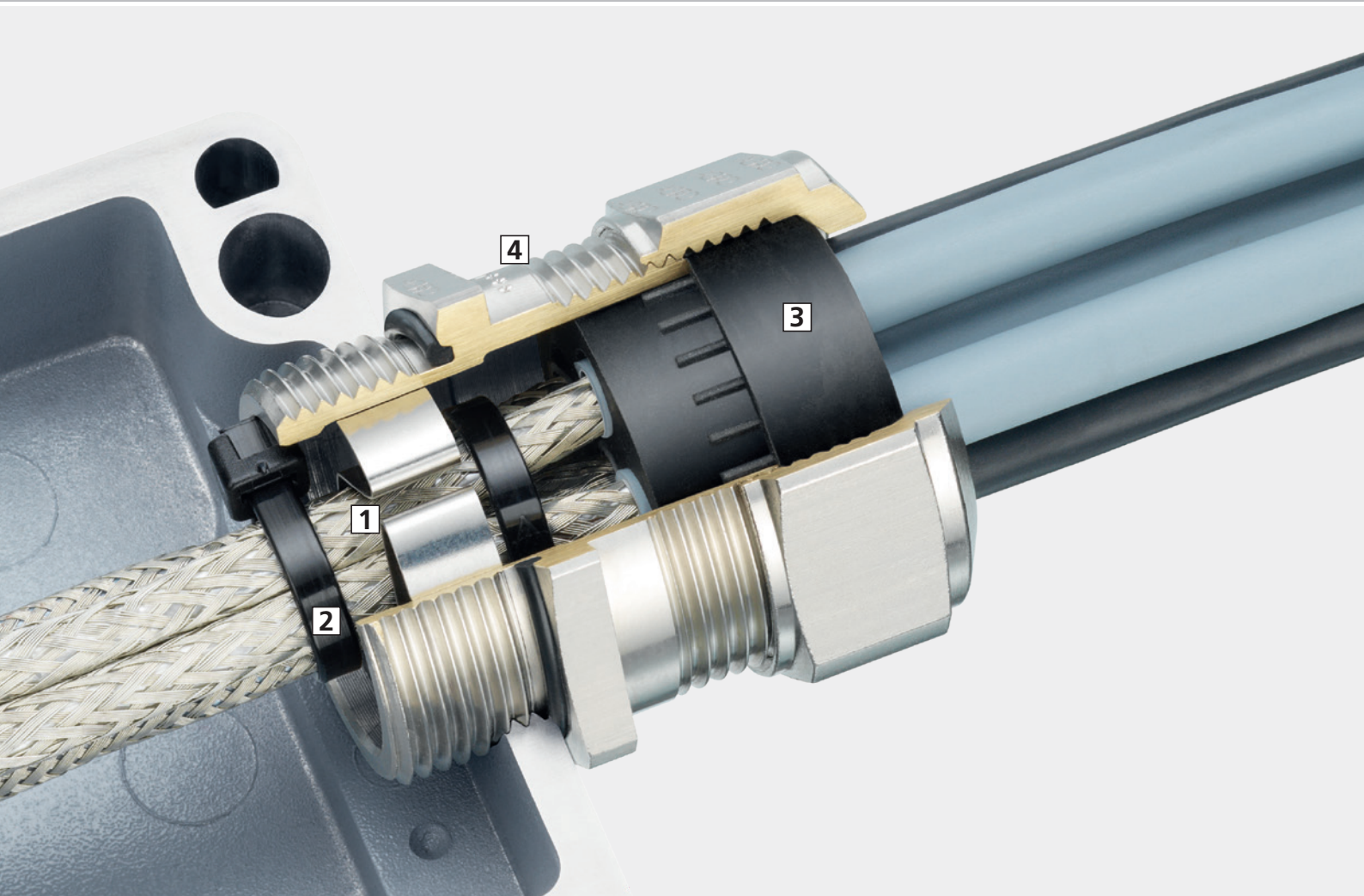

# Progress® EMC easyCONNECT Multi.

## Innovative contact spring for safe contact of several shielded cables.

The Progress® easyCONNECT Multi is the first cable gland that facilitates the entry of several shielded cables into a cabinet - and this with strong, reliable shield grips.

### 1 Protective clamping

The contact spring can be easily, reliably and quickly applied, avoiding any damage to the shield braiding. For continuous, discontinuous or partially exposed shielding.

### 2 Low transfer resistance

The additional holding together of the individual shield braidings by cable binders ensures excellent discharge values.

### 3 MULTI Sealing inserts

Multi sealing inserts can be used for cables of the same or different diameters, and ensure flawless sealing for protection classes IP 68 / IP 69.

### 4 Easily recognisable

The Progress EMC easyCONNECT Multi can be immediately identified from its EMV/EMC markings.

### Available on request:

- In A2 or A4 steel
- With PG or NPT entry threads
- With FPM sealing inserts
- With sealing inserts of type F in accordance with EN 45545 / NFPA 130

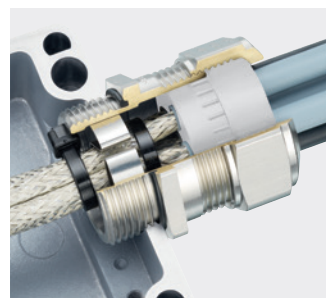



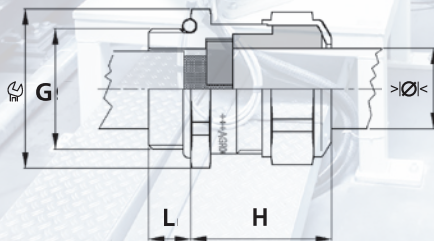
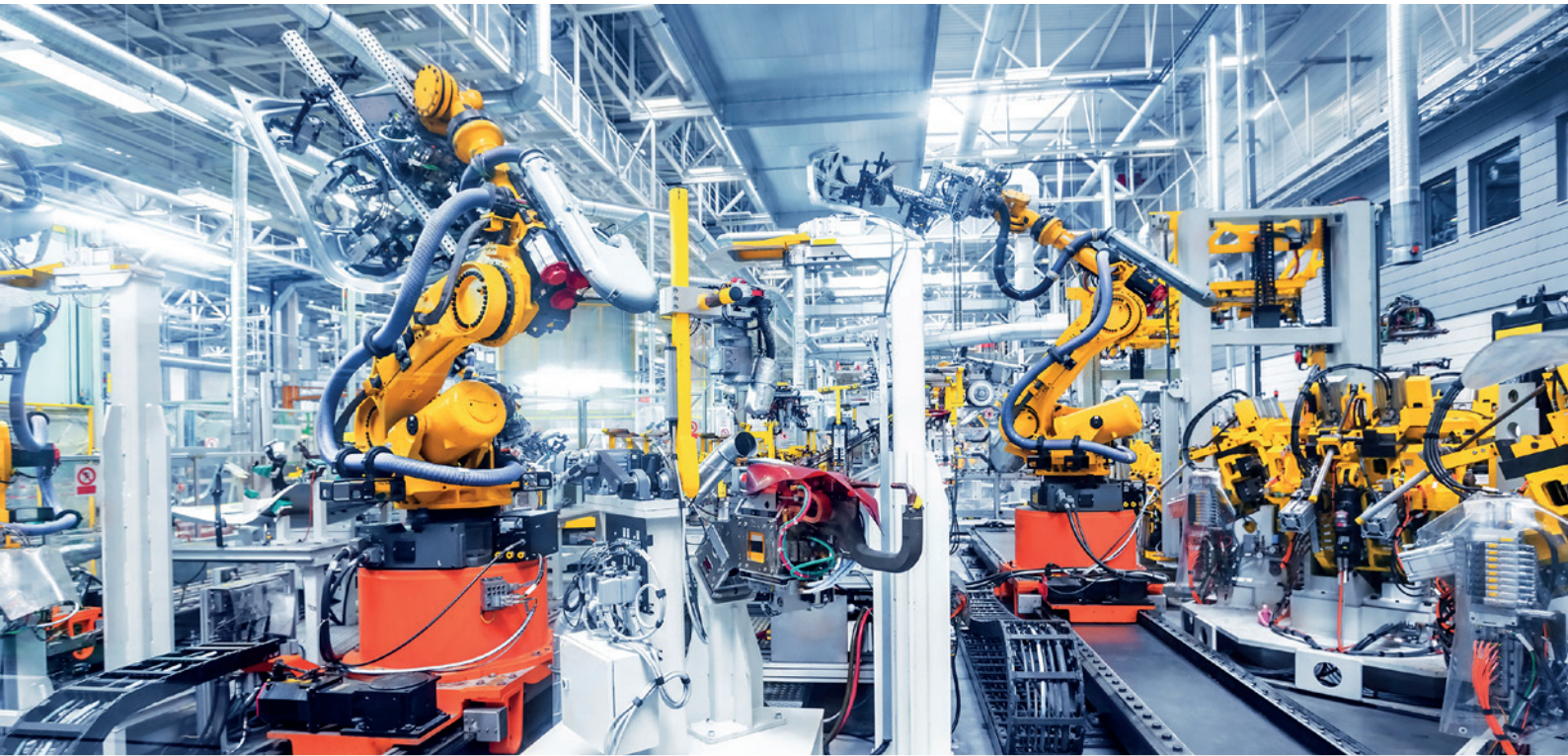

- Material:** Nickel-plated brass
- Contact spring:** Spring steel 1.4310
- Seals:** TPE
- O-ring:** NBR
- Strain relief:** Version A acc. to EN 62444
- Temperature range:** -40°C / +100°C
- Protection class:** IP 68 (up to 10 bar) / IP 69

For shielded cables in limited space conditions, Progress EMV easyConnect Multi is the perfect solution. Whether for cables of the same or differing diameters, or for preassembled, non-preassembled or hybrid cables: The innovative contact spring facilitates problem-free earthing. The presented pictures show only a small selection of the many possibilities.



With standard hole layouts

With customised hole layouts



You specify the number of cable entries and the relevant diameters, and we will supply the EMC Multi cable gland to meet your needs.

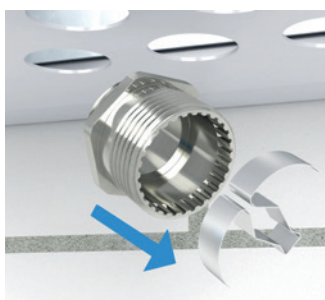

## Further EMC products from our range

			
<b>EMC cable glands with anti-kink spring</b> Art.-No. 1080...52...	<b>Sealing inserts for high temperatures</b> Art.-No. 11080...91...	<b>Combination conduit glands with integrated cable gland Progress® EMC</b> Art.-No. 1710.80...	<b>EMC adapter</b> Art.-No. 1165.84...
			
<b>Combination EMC conduit glands for copper braidings</b> Art.-No. 1165.80...	<b>EMC Rapid with contact disc for increased safety Ex e II</b> Art.-No. EX1081...	<b>EMC with contact sleeve for increased safety Ex e II</b> Art.-No. EX1080...	<b>EMC with contact sleeve and clamps for increased safety Ex e II</b> Art.-No. EX1803.80...

## On request, EMC can be delivered in the following designs

				
<b>Short entry thread</b> • metric • PG • NPT	<b>Long entry thread</b> • metric • PG • NPT	<b>One-piece sealing insert</b> <b>One-piece sealing insert</b> acc. to EN 45545	<b>Two-piece sealing insert</b>	<b>Sealing inserts and o-rings for high temperature applications</b>

Executions in stainless steel:

**A2** (CrNi) steel and acid proof stainless steel **A4** (CrNiMo). For details see our list of materials in the catalogue or on the website.

Available with sealing inserts conformity with EN 45545. When placing an inquiry or an order, prefix the article number by the capital F.

## Accessories

			
<b>EMC locks nut nickel-plated brass with cutting teeth</b> Art.-No. 80...85	<b>Grounding strap for cable glands</b> Art.-No. 10...80.01	<b>Blind discs for cable glands Progress®</b> Art.-No. 10...00.19	<b>Assembly tool for cable glands under cramped confines</b> Art.-No. 4800...

Please find our complete product range and technical details in our catalogue "Cable Glands" or on our Website [www.agro.ch](http://www.agro.ch).

	Progress® nickel-plated brass	EMC Rapid	EMC easyCONNECT	EMC easyCONNECT Multi	EMC Standard	EMC powerCONNECT	EMC Series 85	EMC with anti-kink spring	EMC for high temperatures	EMC combination conduit gland in tapered cable gland	EMC combination conduit gland with copper braiding	EMC Adapter	EMC Accessories	Lock nut with cutting teeth	Grounding straps
<b>Execution</b>															
Compression technology	•	•	•	•	•	•	•	•	•	-	•		-	-	
<b>EMC bonding technology</b>															
Contact disc	•	-	-	-	-	-	-	-	-	-	-		-	-	
Contact spring	-	•	-	-	-	-	-	-	-	-	-		-	-	
Contact sleeve	•	-	•	-	-	•	•	•	•	•	•		-	-	
Compression sleeve	-	-	-	•	-	-	-	-	-	-	-		-	-	
Collet	-	-	-	-	•	-	-	-	-	-	-		-	-	
<b>Characteristics</b>															
Strain relief	•	•	•	•	•	•	•	•	•	-	•		-	-	
Anti-kink protection	-	-	-	-	-	•	-	-	-	-	-		-	-	
Continuation of braided shield	•	•	-	-	•	-	-	-	-	-	-		-	-	
Without continuation of braided shield	•	•	•	•	•	•	•	•	•	•	•		-	-	
Extent of clamping range for the shield	++	+++	+	+++	+	+	+	+	+	+	+		-	-	
Minimal transfer impedance	+	++	++	+++	+++	++	++	++	++	++	++		-	-	
High electrical leakage capacity	-	-	-	+++	+++	-	-	-	-	-	-		-	-	
Can be dismantled without damaging the shield	-	+++	+	++	++	+	+	-	-	-	-		-	-	
Easy installation (quick assembly)	+++	++	+	+	+	+	+	+	+	+	+		-	-	
<b>Entry thread</b>															
Entry thread, metric	•	•	•	•	•	•	•	•	•	•	•		•	•	
Entry thread, PG	•	A	•	A	A	•	•	•	A	•	•		•	•	
Short entry thread (standard)	•	•	•	•	•	•	•	A	A	-	-		-	-	
Short entry thread (standard)	•	•	•	•	A	A	•	•	•	•	•		-	-	
<b>Sealing insert</b>															
for round cables	•	•	•	•	•	•	•	•	•	•	•		-	-	
for conduits	-	-	-	-	-	-	-	•	•	•	•		-	-	
one-piece sealing insert	•	A	•	A	A	•	•	•	A	•	•		-	-	
two-piece sealing	-	•	-	•	•	-	-	-	-	-	-		-	-	
sealing insert for several cables	-	•	-	-	-	-	A	-	-	-	-		-	-	
standard TPE sealing insert	•	•	•	•	•	•	-	•	-	•	•		-	-	
FPM sealing insert	A	A	-	A	A	A	•	A	-	A	•		-	-	
Sealing insert acc. to. EN 45545	A	A	A	A	A	A	-	-	-	-	A		-	-	

- = applicable / available
- = not applicable / not available
- +++ = very well suited
- ++ = well suited
- + = suited
- A = upon request

# Systems and solutions for professional cable routing.



## Cable glands.

Progress® and Syntec® cable glands. For cables, the best.



## Protective cable conduits.

Products for applications in mechanical engineering, facilities construction, automobile and rolling stock manufacture, automation and energy engineering.



## E-Mobility.

The Evolution EMC cable gland – developed for the most demanding electromobility applications.

### Technical information and advice

For further information about our products, system solutions and communication media, please visit our website: [www.agro.ch](http://www.agro.ch)

Our team of technical advisors will be happy to answer any questions you may have or provide further information, and looks forward to speaking with you: **+41 (0)62 889 47 47**



**AGRO AG**  
CH-5502 Hunzenschwil  
Tel. +41(0)62 889 47 47 · Fax +41(0)62 889 47 50  
[www.agro.ch](http://www.agro.ch) · [info@agro.ch](mailto:info@agro.ch)  
Member of KAISER GROUP

 **AGRO**  
... your quality-connection