

WAIN Connector

*The certification icons shown on the cover only represent the certifications covered by the entire catalog.
For the certifications of each product, please refer to the technical characteristics of the product in the catalog.

WAIN is not only **manufacturing**, but also **creating**!

Any questions and ideas related to industrial connectors,
we welcome to discuss with you.

WAIN Heavy duty connector

Heavy-duty connector is designed for modular production pre-wiring and satisfying severe environmental conditions, which is mainly applied in rail transit, industrial automation and equipment manufacturing fields.

Compared with traditional wiring methods, use of heavy-duty connector can reduce site wiring operation after equipment or vehicle leaves the workshop, enhance production efficiency and reduce quality risk of site wiring.

Flexible production is core reflection of Industrial 4.0 modular design, production and application of all functional modules of equipment can lay solid foundation for flexible production. With deep development of industrial automation, equipment has witnessed more renovation. For example, a large amount of equipment has adopted module design whose functions have been constantly increased according to application demand.

Use of heavy-duty connectors including pneumatic modules, large current modules, electromagnetic shielding modules and D-Sub modules has not only achieved accessible and rapid connection among module equipment, but also has guaranteed transmission of signal and power supply. As for manufacturers of machinery equipment, they can not only obtain safe and reliable connection, but also save installation time and reduce comprehensive production costs. As for end users, they can easily install operation equipment without instructions of any professional personnel, and maintenance also becomes easier. It can not only increase effectiveness and practicality of machinery equipment, but also reduce installation time and reduced equipment repair time.

WAIN is a comprehensive professional enterprise with integration of R&D, manufacture and sales of heavy-duty connectors. The company has modernized work places including injection molding workshop, hardware workshop, casting workshop, electroplating workshop, assembly and mould workshop. In addition, the company has product R&D and product performance testing laboratory and several technical patents. We are dedicated to providing high-quality product for industrial connection system. WAIN connector product has thousands of portfolios and can satisfy electric and signal connection requirements of different fields and different situations.



Contents

Rectangular connector -Inserts

	Rated voltage	Rated current	Number of contacts	Wire Connection	Page
HA Series -the slim inserts	230/400V 250V	10A 16A	3, 4, 10, 16, 32	Crimp / Screw Spring	P01-01 ~ P01-07
HE Series -compact inserts	500V	16A	6, 10, 16, 24, 32, 48	Crimp / Screw Spring	P02-01 ~ P02-10
HVE Series -high voltage inserts	830V 400/690V	16A 16A	3, 6, 10, 12, 20, 16, 32	Screw Crimp	P03-01 ~ P03-12
HVES Series -high voltage inserts	830V	16A	3, 6, 10, 12, 20	Spring	P04-01 ~ P04-08
HEE Series -high density inserts	500V *690V,1000V	16A	10, 18, 32, 46, 40, 64, 92	Crimp	P05-01 ~ P05-11
HEEE Series -high density inserts	400V	16A	32, 72	Crimp	P05E-01 ~ P05E-04
HD&HDD Series -ultra-high density inserts	-120V/~50V 250V *400V, 500V	10A 10A	8 7-216	Crimp	P06-01 ~ P06-24
HSB Series -high heavy-current inserts	400/690V	35A	6, 12	Screw	P07-01 ~ P07-07
HK Series -combination inserts	160-830V	10A-100A	4,4+2,4+4,4+8,6+6,6+12, 6+36,8,8+24,12+2,12+0,	Crimp Screw	P08-01 ~ P08-29
HE AV Series -extendible inserts HD AV Series -extendible inserts	500V 250V	16A 10A	6, 10, 16, 24 40, 64	Screw Screw	P09-01 ~ P09-07 P09-08 ~ P09-14
HM Series -flexible and combined inserts	50-5000V Fiber Optic / Pneumatic	5A-200A	1-42	Crimp / Screw Spring	P10-01 ~ P10-71
HQ Series -compact inserts	230-690V	10A, 16A, 40A	2-17	Crimp Screw	P11-01 ~ P11-19
HC Series -high heavy-current inserts	1150-4000V	200A-1000A	1-4	Crimp Screw	P12-01 ~ P12-28
HCM Series -small sized solder insert	50V	5A	15, 18, 21	Crimp Solder	P12H-01 ~ P12H-06

Rectangular connector-Crimp contacts

Type	Page
5A、10A、16A、40A、70A、100A、200A、250A、350A、650A Crimp	P13-01~P13-07

Rectangular connector-Accessories

Type	Page
PCB-adapter	P14-02~P14-11
Rail bracket	P14-12~P14-13
Ground terminal/Docking frame	P14-14~P14-16
Code pin	P14-17~P14-18
Cable clamp	P14-19
D-Sub adapter	P14-20

Rectangular connector-Hoods/Housings

Size	Type	Page
3A	Hoods/Housings (Plastic, Metal, EMC, Corrosion resistance, H version Pressure tight)	P15-06 ~ P15-16.1
10A	Hoods/Housings(Plastic, Metal)	P15-17 ~ P15-18.1
16A	Metal Hoods/Housings	P15-19 ~ P15-20
32A	Metal Hoods/Housings	P15-21 ~ P15-24
6B	Hoods/Housings (Plastic, Metal, Corrosion resistance, EMC, W version, H version, C version Pressure tight, WW/HV)	P15-25 ~ P15-38.2
10B	Hoods/Housings (Plastic, Metal, Corrosion resistance, EMC, W version, H version, C version Pressure tight, WW/HV)	P15-39 ~ P15-69
16B	Hoods/Housings (Plastic, Metal, Corrosion resistance, EMC, W version, H version, C version Pressure tight, WW/HV)	P15-70 ~ P15-107.1
24B	Hoods/Housings (Plastic, Metal, Corrosion resistance, EMC, W version, H version, C version Pressure tight, WW/HV)	P15-108 ~ P15-150
32B	Hoods/Housings (Metal, WW/HV)	P15-151 ~ P15-159
48B	Hoods/Housings (Metal, WW/HV)	P15-160 ~ P15-162
HC	Hoods/Housings (Plastic, Metal)	P15-163 ~ P15-168
Thickened seal part	(H series BK housing)	P15-169 ~ P15-170

*By adjusting the layout of contacts, they could be applied up to 690V or 1000V.
By adjusting the layout of contacts, they could be applied up to 400V or 500V.

To users: Part of the data pictures in this product manual may be updated. Please refer to the latest data provided by the technical department of our company while selecting the model. For the details, please call 400-882-5885, confirm with the sales personnel of our company or inquire via info@wainconnector.com.

Contents

PCB Connector

Type	Rated voltage	Rated current	Number of contacts	Terminal	Page
	1.5V	6A	48	Crimp, Solder	P15F-01 ~ P15F-06

Circular connector

	Rated voltage	Rated current	Number of contacts	Terminal	Page
Technical characteristics					P16-02 ~ P16-10
M8	30V,60V	4A	3,4,5	screw clamp connection, solder,dip solder, moulded	P17-01 ~ P17-22
M12-A	60V, 125V, 250V	2A, 4A, 8A	3,4,5,8,12	screw clamp connection, solder,dip solder, moulded,single wires	P18-01 ~ P18-41
M12-B	125V, 250V	4A, 8A	2,3,4,5	screw clamp connection, solder,dip solder, moulded,single wires	P18B-01 ~ P18B-28
M12-D	250V	4A	4	screw clamp connection, solder,dip solder, moulded,single wires	P19-01 ~ P19-16
M12-S ★	630V	16A, 12A	3, 4	crimp terminal	P19S-01 ~ P19S-16
M12-X	250V	4A	8	crimp terminal,single wires	P19X-01 ~ P19X-09
M8/M12 Distributor M8/M12 Sensor junction box	60/250V 10~30V DC	4A 2A, 9A	4,5 4,5	- pluggable M23	P20-01 ~ P20-05
7/8	300V	8A, 9A, 10A, 12A	3(2+PE),4(3+PE),5(4+PE)	screw clamp connection,	P21-01 ~ P21-08
M17	32V, 60V, 630V	3.6A, 7A, 14A	7,12,17	crimp terminal	P21S-01 ~ P21S-11
HR23(M23)	25V~/60V-	7A, 15A	6,9,12,17,19	crimp terminal, (PCB)solder terminal screw clamp connection	P22-01 ~ P22-14
MR23	25V~/60V-	7A	12,17	crimp terminal	P23-01 ~ P23-07
M23	250V, 630V	9A, 30A	6,8	crimp terminal	P24-01~ P24-10
M40	250V	20A, 60A	4/4	crimp terminal	P25-01~ P25-05
Q38 ★	250V	13A, 30A	12+19, 32 (28+4), 48	Quick connect card slot	P25Q-01~ P25Q-06
Power electrical connector	220V, 250V	1A, 13A, 20A, 25A, 40A	4,5,6,10,26,RJ45&3	crimp terminal, solder terminal	P26-01~ P26-08
Customized product-HW	1000V	800A	1	crimp terminal	P27-01~ P27-04
Customized product-MI	400/30V	6/1A	6+6(5+PE)	crimp terminal	P27-05~ P27-06

Personalized product

	Rated voltage	Rated current	Number of contacts	Terminal	Page
HCC Series-single row inserts	500V	30A	10	Screw terminal	P28-01 ~ P28-02
HV Series-single row inserts	400V	20A	8	Screw terminal	P29-01 ~ P29-04
The State Grid Anti-Open Connector	500V/250V	40A, 10A	24+8 (anti-open circuit) +1 (grounding) 8+8 (anti-open circuit)+40 6+PE	crimp terminal, (PCB)solder terminal screw clamp connection	P29-05 ~ P29-08.6
D-Sub-044 Series		3A	44	crimp terminal	P29-09 ~ P29-12
Charging socket / Test Tool (TL-DZ)	500V/12V	150A, 2A	8/2	crimp terminal	P29-13 ~ P29-18
IO / WP Series ★	100V (IO)	0.5A(IO)	18(IO)		P29-19 ~ P29-22
wiring harness					P30-01 ~ P30-14
Optical fiber					P31-01 ~ P31-04

Tools/Cable gland

	Page
Tools/Cable gland	P32-01 ~ P32-25
List of part no.	P33-01 ~ P33-33

Certification

System certificates



ISO 14001 Certification



ISO 9001 EN(TUV)Certification



ISO 9001 中文 (TUV)Certification



IRIS Certification

Product certificates



VDE Certification



UL Certification



CE Certification



CQC Certification



EAC Certification

Introduction to IRIS: IRIS, standing for International Railway Industry Standard, is an initiative led by the Union of the European Railway Industries (UNIFE). It is mainly used to ensure the high quality of the whole railway industry and make the manufacturers of railway equipment meet the requirements of global railways for high-quality railway parts and increase their competitiveness in the world. IRIS aims to develop and implement a universal system to evaluate the quality management systems of railway industry. IRIS adds railway specific requirements into ISO 9001; in short, IRIS is the extension of ISO 9001 for railway industry.

EUROMAP WAIN is one of the recommended suppliers of EUROMAP, the Europe's Association for plastics and rubber machinery manufacturers.

EUROMAP recommendations:

The inserts and the relevant enclosures meet the EUROMAP Recommendations (European Committee of machinery manufacturers for the plastic and rubber industry) EUROMAP 12, 13, 14.1, 14.2, 16, 27.1, 28, 29, 62, 67, 67.1, 70, 73, 74, 78

For more information, please visit WAIN's homepage: www.wainconnector.com

WAIN "WU" single module connector series

The innovative products of WAIN in 2016 combine dozens of modules (large current, signal current, optical fiber, gas, Ethernet and so on) into an independent unit with EMC performance and a protection level of IP65.

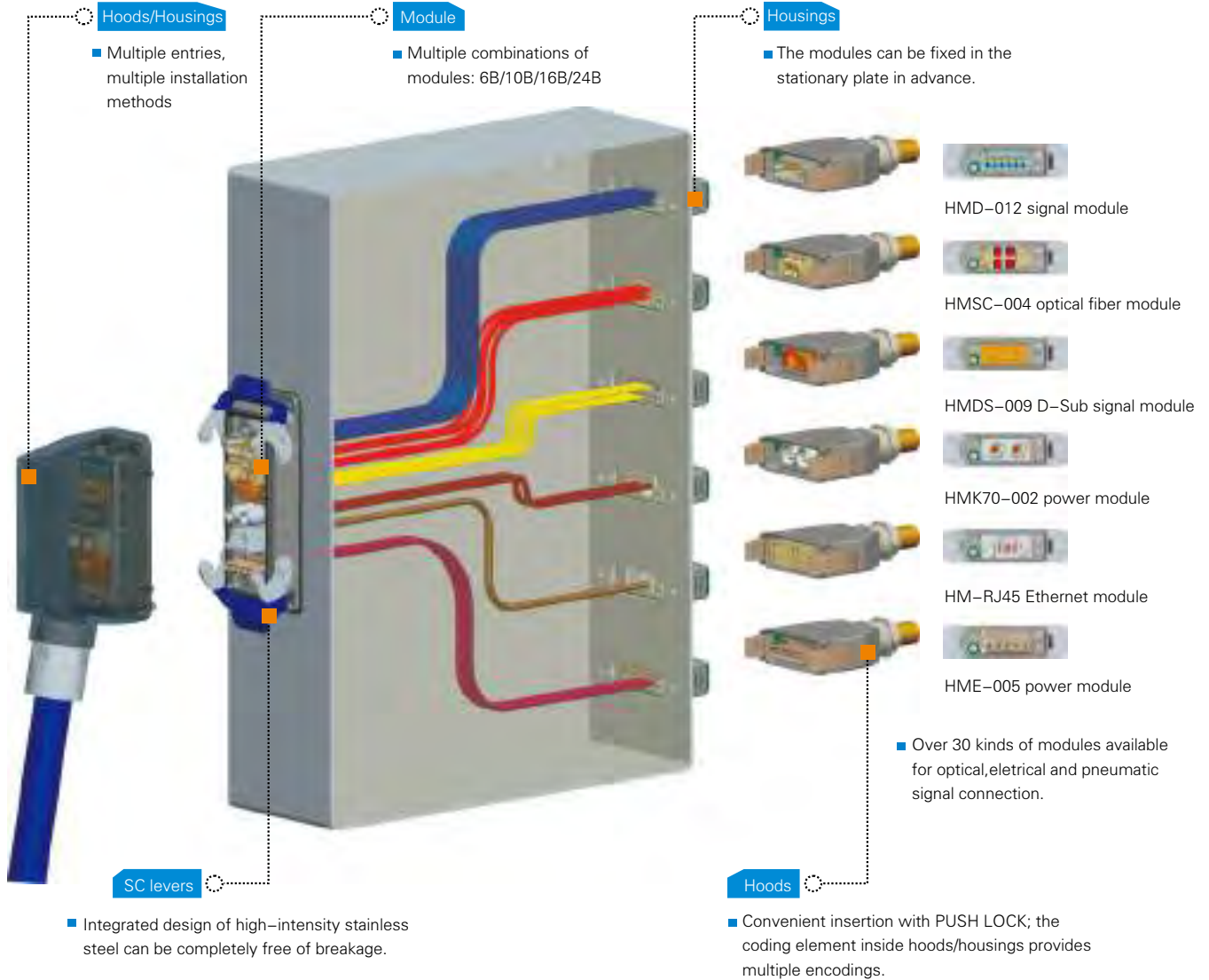

WAIN provides solutions for various branching integration demands!

Characteristics

- smaller width, more compact, space-saving;
- convenient locks save time during assembly;
- encoder inside hoods/housings provides multiple encodings;
- modules can be fixed in the stationary plate in advance;
- With grounding function;
- Grounding screw is in vertical direction, which does not interfere with the face plate so that operation space is large;
- It is matched with multiple single module slugs;
- EMC function;

For more information about the hoods, housings and modules of "WU" Series, please refer to HM Series.

WAIN joins the EPLAN Data Portal

We are glad to inform you that WAIN products are now available in the EPLAN Data Portal. There are more than 3500 components online for your reference. In this way, customers can select WAIN products more quickly and conveniently so as to save the time of design and production, furthermore, improve efficiency.



- WAIN has more than **26578**^[1] products, which are applicable in most of the industrial application scenarios!
- Wain offers also customization service for industrial connectors!

[1] Data sourced from WAIN-ERP System, statistics time: 2023.07.01.



WAIN new hoods/housings (IP67)

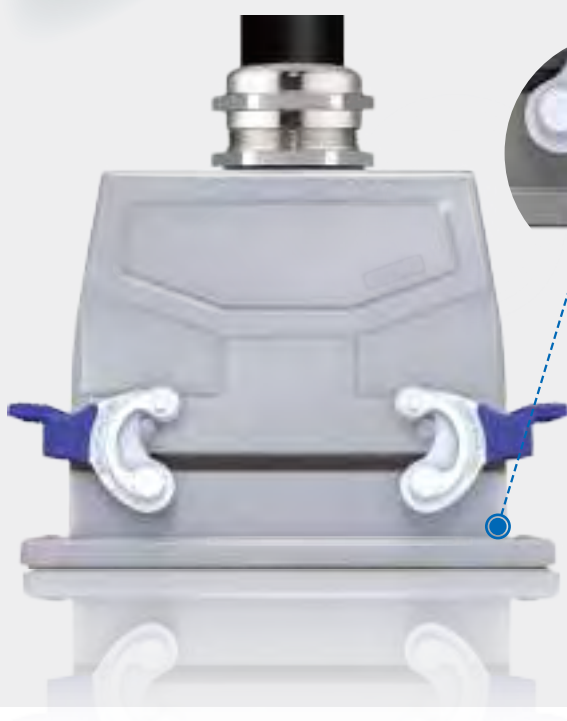

■ Glue-free bottom base

Hidden base pad, better corrosion resistance!

Characteristics

- New appearance by independent development.
- Degree of protection IP67.
- The hidden glue-free bottom base provides better corrosion resistance.
- Compatible with the old-designed hoods/housings.

WAIN metal docking frame

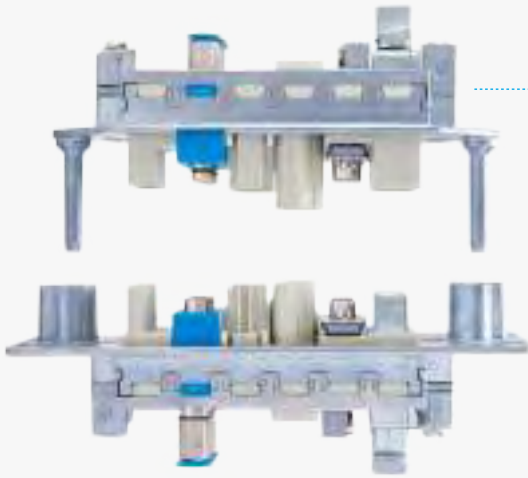

Direct installation without hood and housing

Characteristics

- Easy assembly and disassembly with hanging type half-threaded screws.
- Putting guiding pins into conical holes to realize guiding.
- Using the floating washers to increase gaps, it helps to increase guiding function.
- Guiding through crown spring improves the safety performance greatly.
- Direct installation and no need to match with hoods/housings.

WAIN metal pneumatic module



Characteristics

- Easy assembly and disassembly of contacts and modules by using contact removal tools.
- Quick connection and disconnection of the air tube.
- Metal pneumatic contact increases strength and service life of the module.

WAIN MR23 circular connector

- Efficient mounting and removal of contacts through Push-Pull mounting technology



Characteristics

- Crimp connection stabilizes the signal transmission in vibration environment.
- Push-Pull mounting technology realizes efficient mounting and removal without any tool.
- Reverse coding is also available.

WAIN extra large plastic hood



- Largest wire diameter of $\Phi 47\text{mm}$



Characteristics

- The hood is designed as a separate structure, easy assembly and disassembly with screws
- Enlarged space inside the hood makes it convenient to connect and install large cables
- Mating hood and housing with locking levers, the connector will not easily fall apart
- Excellent electrical insulating property (Insulating resistance $> 10 \Omega$)
- High performance material suits the harsh environment
- Light weight, high mechanical properties and economical
- Widely used in various applications, compatible with regular inserts, frames, etc.

WAIN 32 pin anti-open circuit connector



Assembly and welding of two-stage welding pins
The stress relief structure of PCB electrical connection can release the stress, so as to protect PCB from damage.



Characteristics

- The stress relief structure of PCB electrical connection can release the stress, so as to protect PCB from damage.
- Assembly and welding of two-stage welding pins: one or more pins and PCB at male end welded with female plug at the same time; better protection of welding points; more effective and reliable operation of the system; easy installation and maintainance.

WAIN modular type plastic hoods/housings



- Snap-in type, easy to operate.

- Compared with metal frame, there is one more module space.



Characteristics

- The hoods and housings are connected by special latch design, which prevents from falling off.
- High performance materials are adapted to harsh environment.
- Light weight, high mechanical strength and low costs.

WAIN 7/8 Circular connector

- Screw terminal, Easy assembly on site.



Characteristics

- Original anti-loosing joint to avoid accidental loosening, with superior performance in shock resistance and vibration load.
- 7/8 flange seat with fixed cable wiring design, greatly improving cable life and connection stability.
- Screw terminal, easy to maintain and operate! Easy assembly on site.
- Patented design with sleeve pin to improve mechanical life.
- Superior waterproof, dustproof and explosion-proof performance, with protection grade up to IP67.
- The connector is made of high temperature resistant material, with the maximum temperature of 125 °C, and the fire rating of UL94V0

WAIN enlarge metal hood

- Internal space up to 63mm wide
Large cable, easier wiring and installation!



Characteristics

- The internal space of the conventional 24B high structure hood is only 34mm, and the internal space of this extra large shell can reach 63mm.
- Increase the internal space to ensure that the cable with large cable outer diameter can also be wired.
- It is made of aluminum alloy metal with high strength and long service life!
- It can be compatible with conventional insert, frame and other usage, and has a wide range of uses.
- Wiring methods: side entry/top entry.

WAIN new and upgraded modules



The max is up to 2.5mm² terminal connection

Open cover up and down.
Simple insertion in the corresponding insert
hole position when installing.
Easy operation.

Limiting stopper buckle, design of the cover against falling off.



Function of coding pin.

Characteristics

- There is a cover barrier between the insert and shell, which ensures sufficient creepage distance and reliable electrical performance.
- The top outlet avoids folding the wire to 90° then upwards, as by side outlet. The operation is convenient by wiring.
- The protective cover has a reliable structure. The cover will not fall off when pushed up and down.
- It has the function of coding pin, including 4 encoding modes.

WAIN independently developed "TL-DZ Contact retention test tool"

The indicator

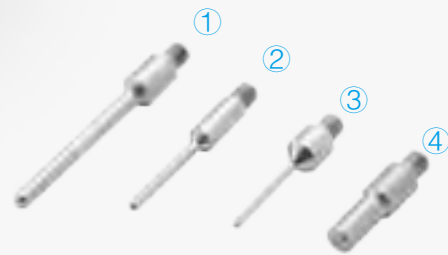
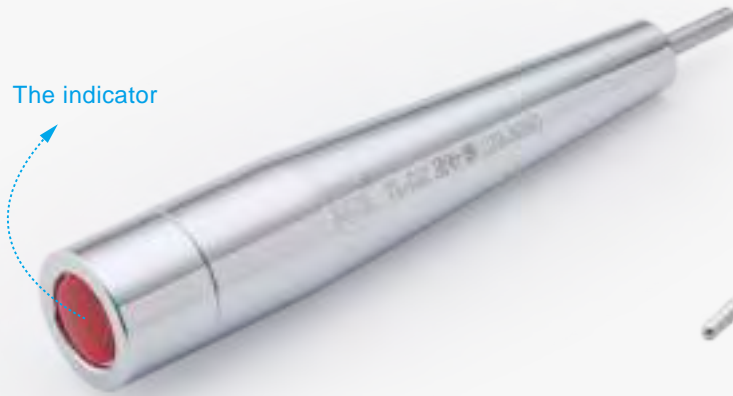

WAIN TL-DZ Contact retention test tool is a kind of tool for detecting contact retention, using the LED indicator function to visualise the test results. The tool is compact and simple to operate, chrome-plated and fine in appearance. It has a mechanical life of over 100,000 times, a variety of free replaceable heads and is compatible with various contact detection, whose detection strength is customizable!

*Please refer to P31-05~P31-06 for selection and operation.

- ① Female head: used for the detection of 16A female contact (optional)
- ② Female head: used for the detection of 10A female contact (standard)
- ③ Female head: used for the detection of 5A female contact (standard)
- ④ male head: used for the detection of 5A/10A/16A male contact detection (standard)

WAIN M12 circular connector,X-coded



The high data transmission speed is up to 10Gbps.

Characteristics

- High data transmission speed, up to 10Gbps.
- Full metal shell, effectively anti-electromagnetic interference.
- Cold-pressed contacts, effectively anti-vibration and highly data transmission stabilizing.
- Fixition of contacts into inserts by side press, easy assembly and maintainance without tools.

WAIN 1440 shell



The neutral salt spray test
is up to **1440** hours
(C5H grade)

1440 Shell

- Adopting the special treatment process.
- The neutral salt spray test is up to 1440 hours (C5H grade).
- Applicable to all the aluminum alloy shell.
- Applicable in the environment with high anti-corrosion requirements.

WAIN metal docking frame with Single module



Characteristics

- Easy assembly and disassembly with hanging type half-threaded screws.
- Putting guiding pins into conical holes to realize guiding.
- Using the floating washers to increase gaps, it helps to increase guiding function.
- Guiding through crown spring improves the safety performance greatly.
- Direct installation and no need to match with hoods/housings.

WAIN HM-RJ45-M/F module

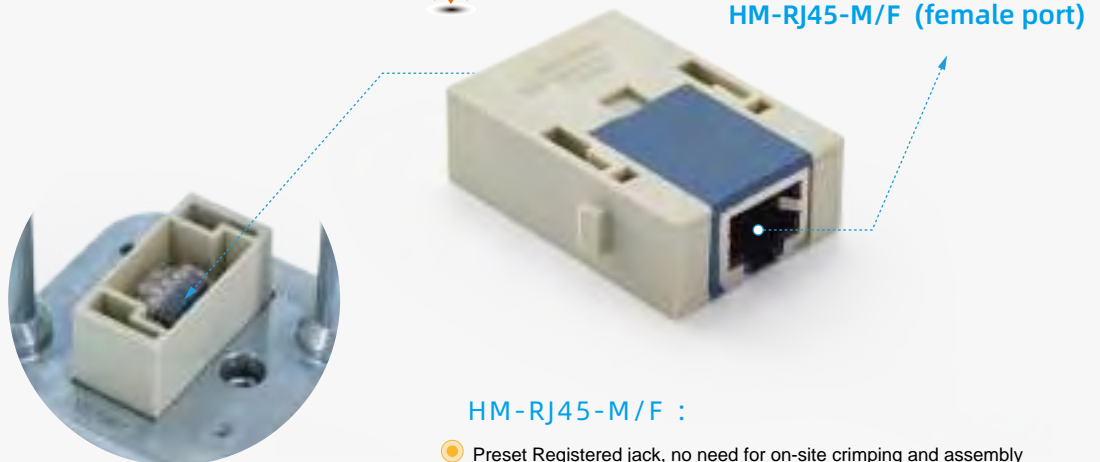

HM-RJ45-M/F (male port)

HM-RJ45-M/F (female port)

HM-RJ45-M/F :

- Preset Registered jack, no need for on-site crimping and assembly
- The male module does not require additional adapter assembly
- Suitable for WAIN standard framework or single module framework
- Transmission features : Category 6 /Class E up to 500 MHz

Note: For single module metal frame, please refer to P10-06.1, and for HM-RJ45-M/F module, please refer to P10-49.1

WAIN quick-in wiring technology series

80%

● Reduced about 80% time compared with traditional wiring.



■ Characteristics

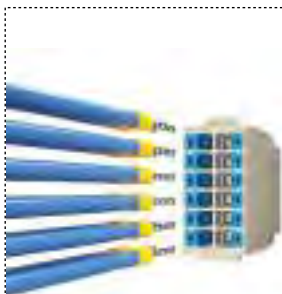

Save time

Reduced about 80% time compared with traditional wiring.



Fast lock

Straight-in spring, unique lock design



Support a variety of wires

Hard wire cable
Wire with terminal
Flexible cable



Vibration-proof

Strong connection

WAIN New Spring Version Quick-in Insert



- Integrated jumping ports
- Integrated jumping ports
- Mating cycle of terminal jumper ≥ 500 times

■ Characteristics

● **Insert directly for quick-in wiring**
Wire with the ferrule hard wire tin-soaked wire

● **Varieties of jumpers**
Free combination

● **Vibration-proof**
Interference point design

● **Application in hot runner injection Molding machine and other industries**

● **With test port**
The test port diameter is 1.95mm, while the test lead has a diameter of 2.00mm.
The slightly smaller test port reduces shaking of the test lead and increase the test stability.

WAIN underwater connector technology

7000 m

● High reliability **wet mating** underwater at **7000m**.



■ Characteristics



High compression resistance and corrosion resistance.
Adoption of high-strength titanium alloy.

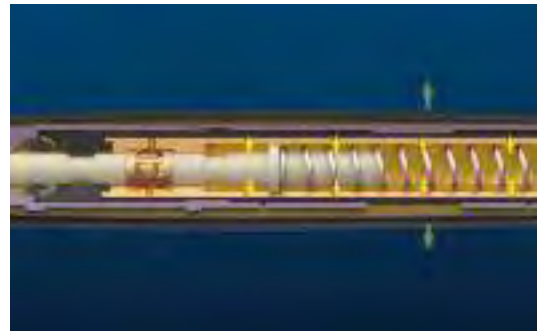

Double layer oil sealing.
Automatic flushing and purification when mating.
Pressure balance under deep sea.

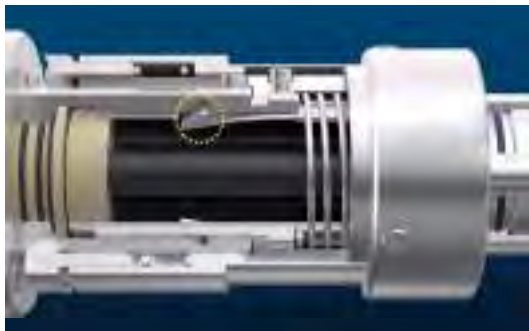

Male and female mating self-locking function.
Self-locking completed when unplugged.



Safe and reliable connection.

WAIN high voltage connection system of new energy vehicle



High voltage interconnection diagram of EV

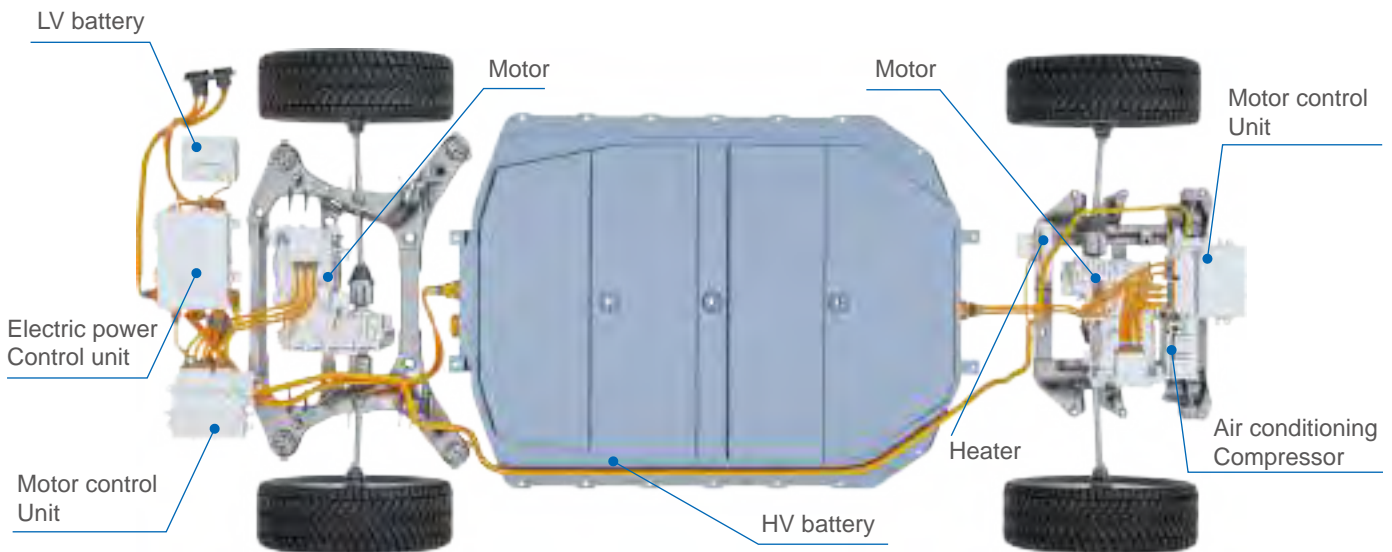

WAIN high current connector

- Quick mating Dafe and reliable Patented design

Quick nut reversing device

Color coded for 3-phase identification



Rapid fastening



Contraction gap
Prevent connector damage



Double crown spring to
Increase contact surface



Super load-bearing tensile strength



Electric shock proof

WAIN m12 junction box

- Compact structure, elegant appearance, convenient wiring, strong scalability.



**Prefabricated cables, on-site wiring.
Meeting the needs of different customers.**



Led power and signal indicators give real-time feedback of product status.



Forming 90° angle to each other. Adapted to straight, bent and other connectors.



Compatible with a variety of small distributors.

WAIN PCB connector

- Connecting PCB for signal transmission

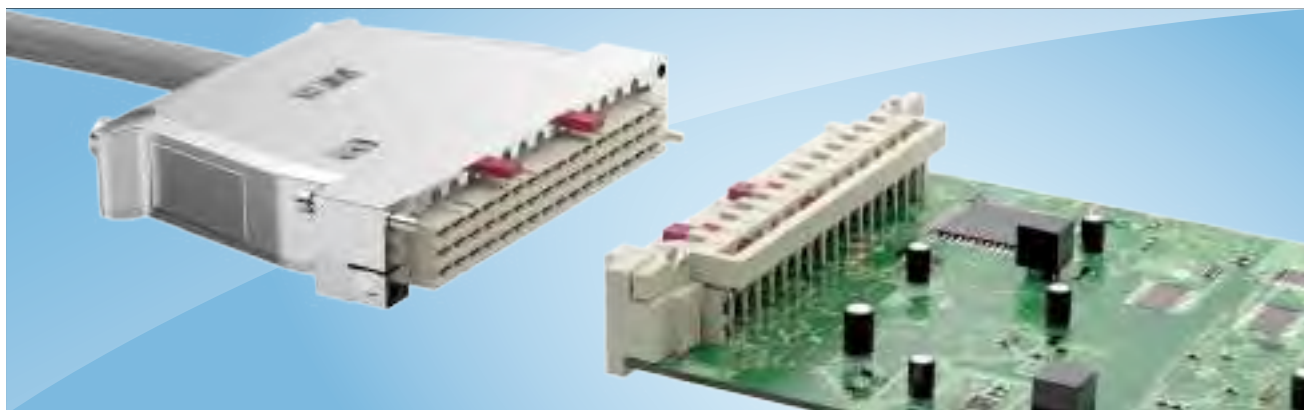

■ Characteristics



Full metal shell, rugged and durable



4 optional cable outlet methods



Reversible cable clamp, flexible and convenient



Supports coding fool-proof mechanism

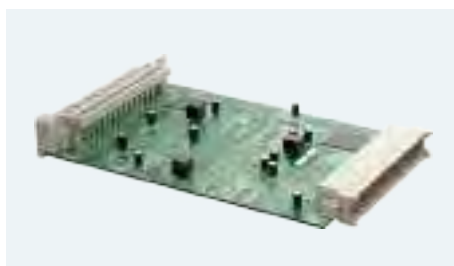

PCB welded used for signal transmission



Perfect for rail transit applications

WAIN PCB connector

- Perfect for electric control cabinet of construction. Machinery applications and so on.

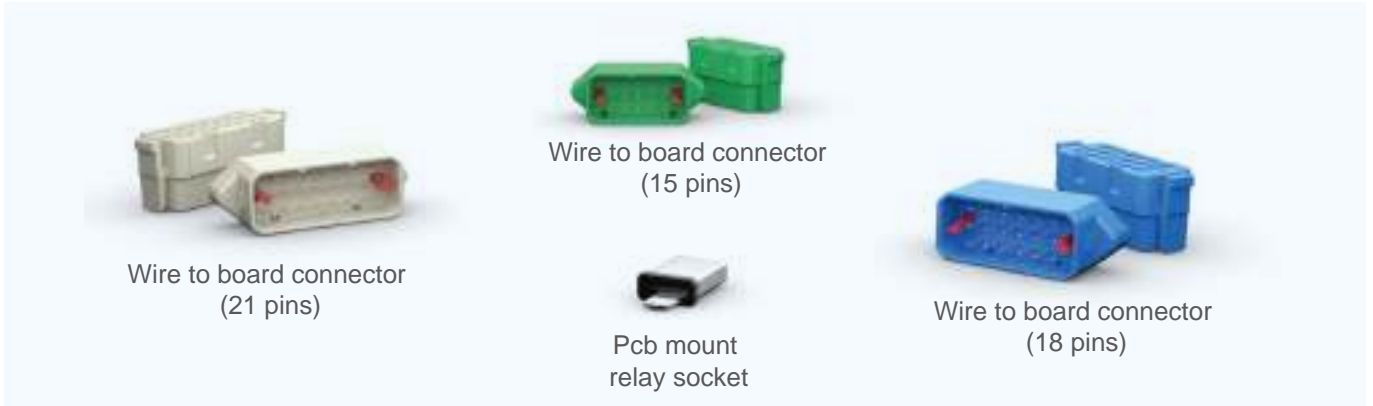

Wire to board connector

For signal transmission



Pcb mount relay socket

For relay pcb mounting



Intuitive double row spring contact

Double contact surface

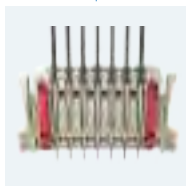

Pin coded fool-proof



Color coded fool-proof

Engineered for rapid connectivity between circuits



Integrated rubber shock absorber

Preventing pcb board from crushing



Easy to install

Reliable soldered installation

WAIN terminal block type connector

WAIN terminal block type that extends into the cabinet can be applied to not only wiring installation in the control cabinet in the industrial industry, but also to guide rail connection. The connector is convenient for on-site operation, repair and maintenance. The wiring process is simplified by prefabricated cables, which is fast and effective.

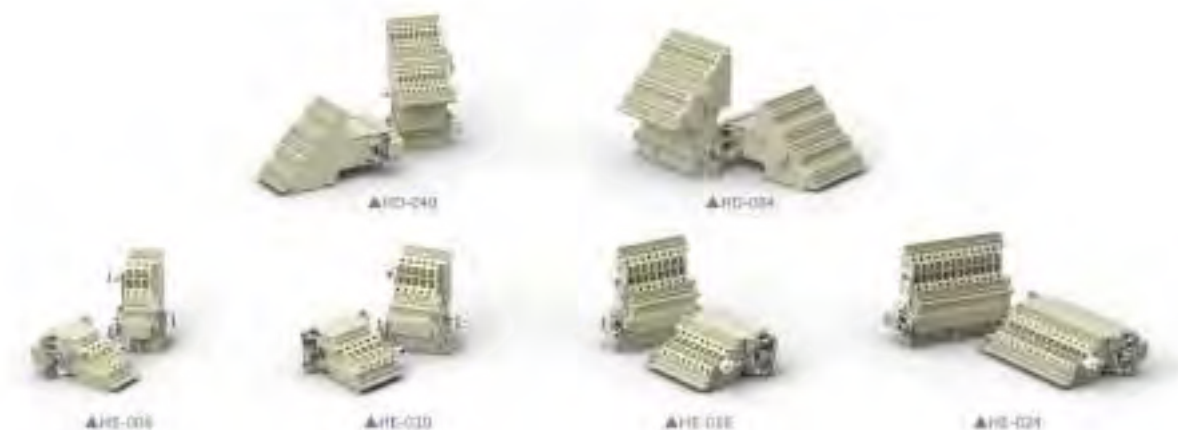

■ Characteristics



Installation outside the cabinet

Wiring in the cabinet is convenient for on-site operation, repair and maintenance.

Non-PE side terminal first into the bulkhead mounted housing.

Installation inside the cabinet

Prefabricated cables, fast and effective wiring



Easy connection outside the cabinet



Extensive application

Matched with locking elements, the connector can be directly applied to the guide rail.

WAIN PCB connector

- High density insert 108 pins

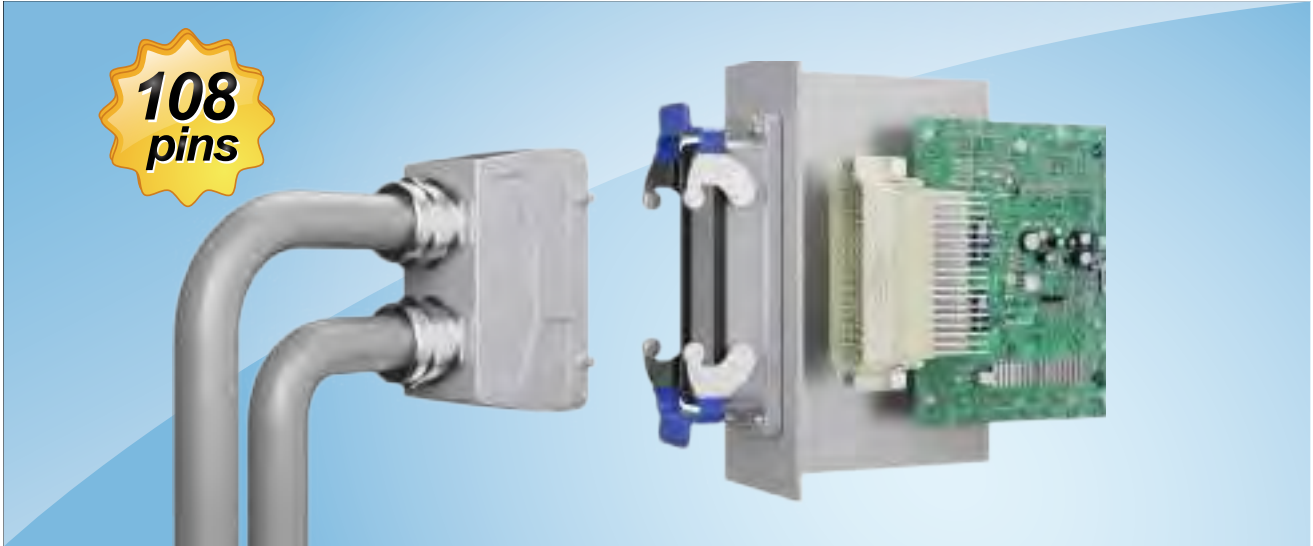

90° angle wire-to-board connector

Used with different PCB layout, either 90° or 180°

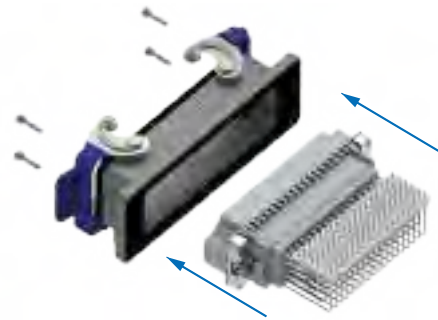

Advance method

Reverse insert assembly
 Assembly and disassembly outside the cabinet
 Convenient installation and maintenance



Pcb overall soldering wiring;

High assembly efficiency



108 pins with fixing plate

Quick and easy insertion

WAIN CCAB rail bracket

- Convenient assembly and flexible position change



Technical information

Applicable rail specification (DIN BN60715: 35*7.5 or 35*15)

Minimum supporting force on supporting rail $\geq 450\text{N}$

Material: PC

Flame retardant rating: V0 (according to UL94)

Operating temperature range: $-40^{\circ}\text{C}\sim 125^{\circ}\text{C}$

Application: Inserts and modular frames of all compatible with B size shells.



Suitable for modular frames and inserts with different specifications



**Adjustable construction
Compatible with 6B 10B 16B 24B.**



Secure and reliable insert locking mechanism, easy disassembly.

Cables can be locked with cable clamps.

Snap-in docking mechanism, easy handling.



Compatible with horizontal and vertical rails, ideal for flexible field installation.

The protection cover protects the cables against dust deposits and unnecessary contact.

Easy Identification Tag.

WAIN LED display connector

- Providing signal and power connection

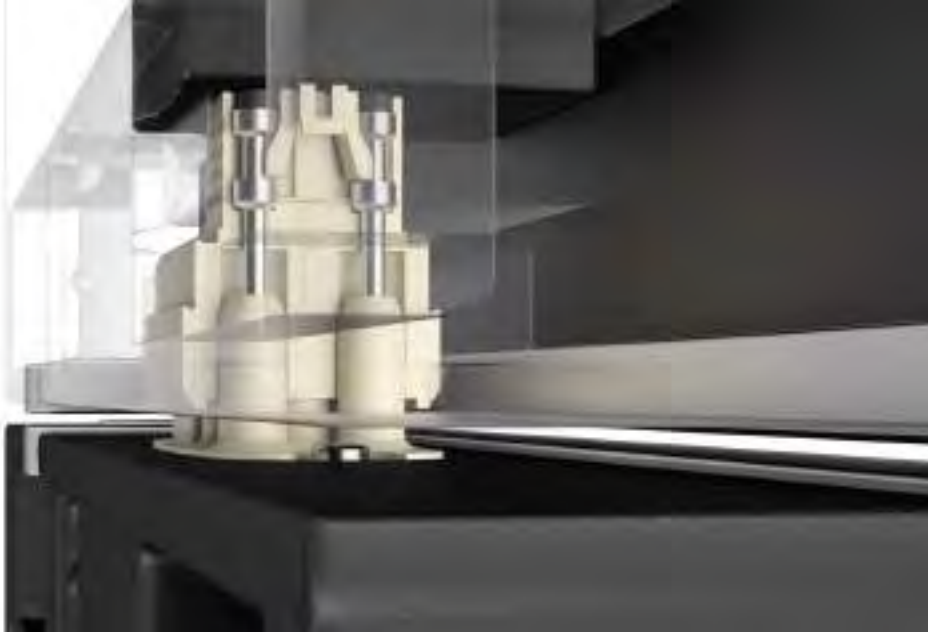

■ Characteristics



With signal and power transmission



The screws are pre-hung and do not fall off



High mating and good reliability

Suitable for standard metal shielded RJ45 crystal head



Easy assembly and disassembly, good stability

Metal shielding module



Mating fast and safe

Fool-proofing mating chamfering guide



Floating docking

WAIN 24 contacts shielding module

● Small space, big satisfaction.



Technical information

HMSB-024-MC/FC(Signal Module)

Number of contacts: 24+Shielding

Rated current: 4A

Rated voltage: 32V

■ Characteristics



**Single module
Metal EMC shielding**



**EMC electromagnetic
shielding**



**Single module
24 signal contacts**



**Flexible match with other
modules**



Innovative foolproof design



**A wide range of cable
clamping capacity,
a variety of wire gauge
available.**

WAIN coaxial module

- Designed for RF communication equipment

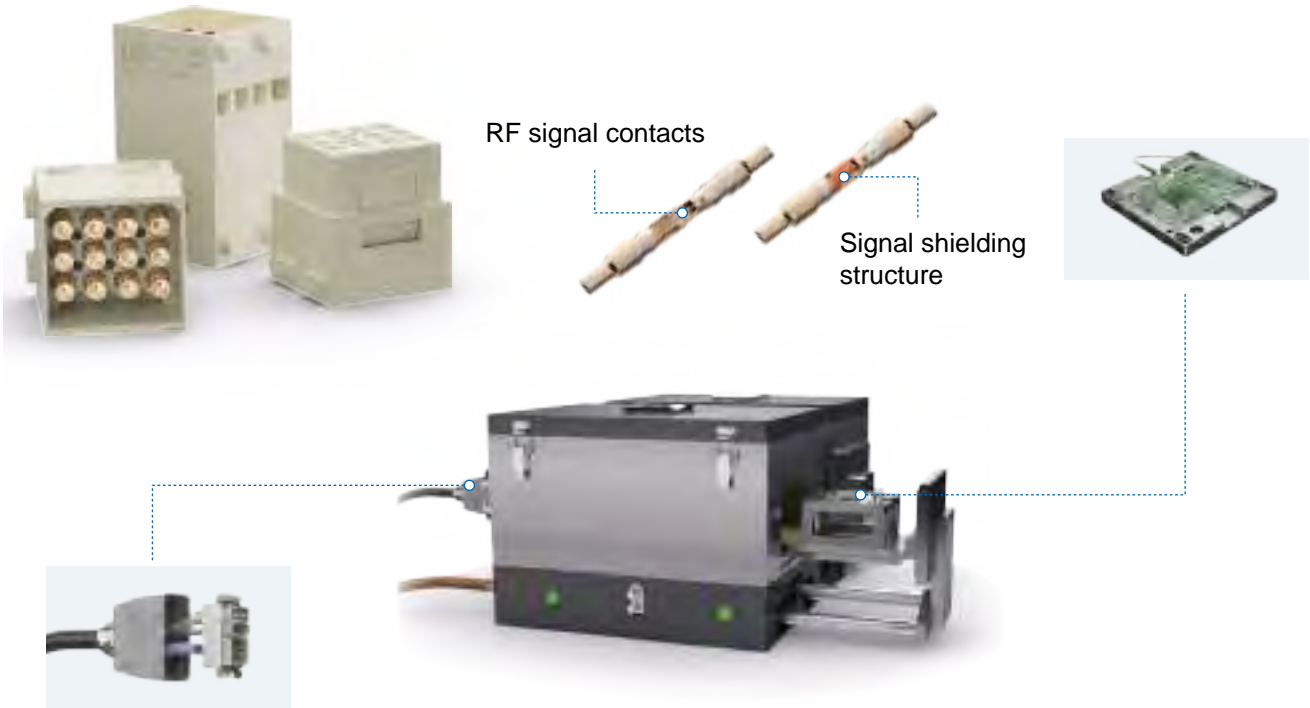

Characteristics



For RF signal transmission



Easy assembly by pushing contacts direct from insert bottom



Foolproof design



One module supports up to 12 channels



Quick and easy disassembly with contact removal tools



Flexible combination with other modules

WAIN modular connector

- Connecting unlimited possibilities.

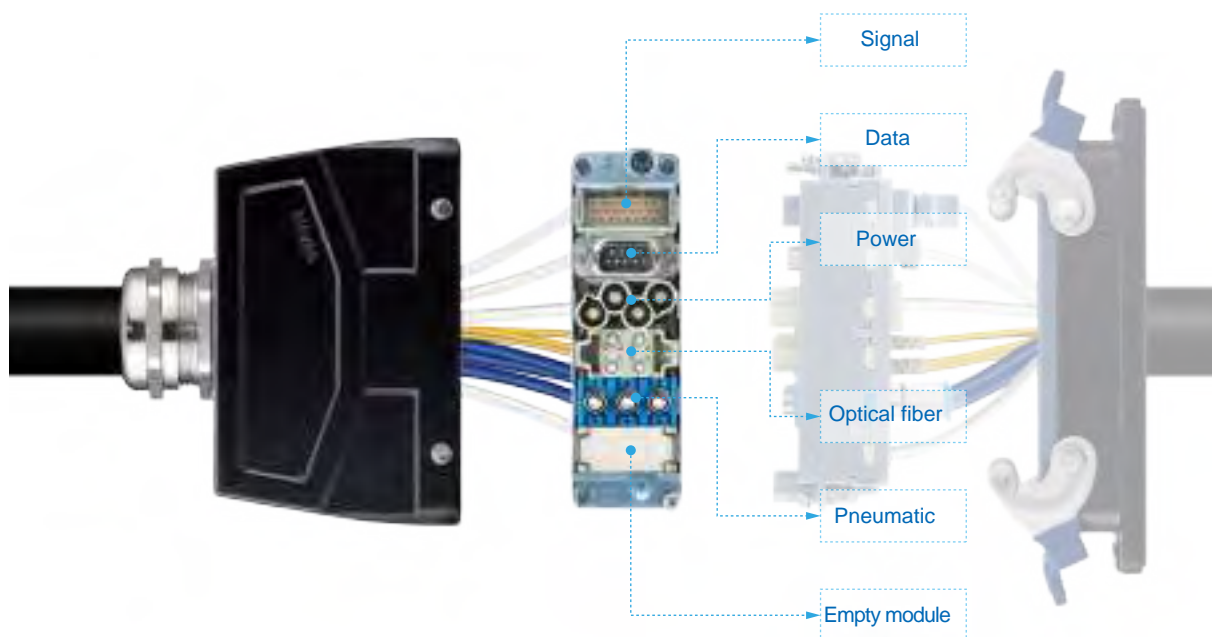

Five advantages of wain module system

- Perfect integration of power, signal, optical fiber, and fluid connection.
- The pre-assembled cable harness is rapid, professional, reliable and timesaving.
- The standard size fulfills multi-transmission and saves space.
- Various module combination within one connector saves costs.
- Reserving dummy modules, to change in constant.



Flexibly / High versatility



WAIN hot mating connector with emergency disconnection function

- Protection for the data center with fuse function



■ Characteristics

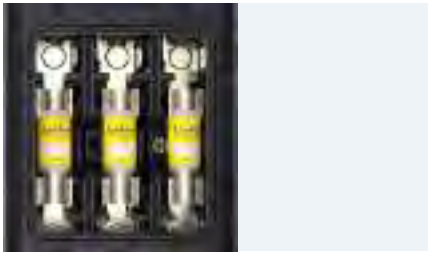

Pre-installed fuse



Protection of circuits and equipment

Instantaneous disconnection of the circuit in the situation of current overload



Transparent shell design

Easy observation and replacement of components



Fuse function

Withstanding emergency disconnection



IP protection design

Protection for circuits and equipments



Data center

Additional security protection

WAIN data & communication modular connector

- A diverse product portfolio of communication modular connectors



Various interfaces



X-Code

Safe and reliable 10Gbps high-speed data transmission



D-Sub

Transmission of analog, digital and series data



Fiber optic module

For high-speed optical fiber transmission



CAT6A

Bandwidth up to 500MHz, less crosstalk.



Coaxial module

RF signal transmission



Communication modules

Flexible combination into modular connectors

WAIN circular connector

- Extensive range of circular connector products



Wide selection of product series, abundant variations of product structure.



Our connector portfolio includes: A Code, B Code.....



A Code



B Code



D Code



X Code

Various pins configurations available



WAIN MI mini connector

- Small connector for power and signal in one



With the top+side wall open design. ←
Cable can be easily perforated, convenient to install and disassemble.

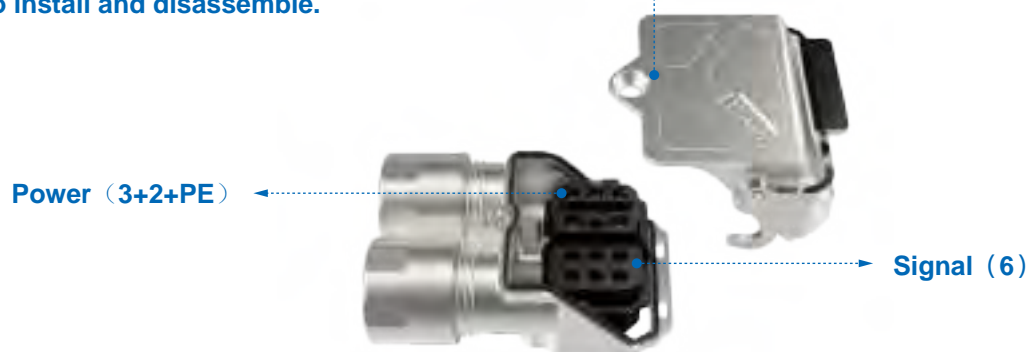

Characteristics

- Adopt button structure to realize rapid installation and disassembly.
- Crimping structure, with the advantages of efficient crimping, earthquake resistance and convenient maintenance.
- Shell is 360 ° overall shielded, and the power and signal areas are isolated separately.
- Double cable outlet, the max diameter of cable outlet can reach $\Phi 7.5$.
- With the top+side wall open design. Cable can be easily perforated, convenient to install and disassemble, and greatly shorten the assembly time.

WAIN Multi-pin Connectors For Vehicle

- Support power and signal at the same time



Characteristics:



High-precision stamped contact for efficient crimping



Easy contact assembling without removing the housing



Support power and signal at the same time



With membrane wire seals that meet the requirements for IP67



Widely used in various fields such as vehicles construction machinery and automation equipment



Solid and reliable fast-locking technology



Note: For details, please refer to Q38 series P25Q-01~ P25Q-06

Product applications

·Energy





·Rail transit



·Machine manufacturing



·Automation





- Convenient maintenance
- Rapid surefooted installation
- Degree of protection IP68

» WAIN provides stable and reliable electrical connection for variable pitch blades and slip rings.



■ Turbine parts



■ Turbine parts



■ Pitch system

】】 Connectors in wind power generation

Wind power generation is the most mature way of power generation, which is qualified for large-scale development and has commercial development prospect., and it has been developed in the recent years. Reliable operation and convenient maintenance and replacement of functional module system are significant for the wind power station.

WAIN Connector provides reliable electrical connection solutions for wind power generation. The HC, HE, RJ45, HR23 series, as well as other series can satisfy various connection of weak and strong current in different applications of wind power.

】】 HK Combination Connectors

- Combination of power and signal area in one connector
- Up to 200A current connection
- Match with various kinds of hoods and housings
- An ideal connector for large current connection in narrow space



” Connectors in Electric power industry

Reliability, safety, economic efficiency, energy efficiency and environment–friendliness are important indicators of power grid operation. Therefore, new–type intelligent power grid taking physical power grid as foundation and integrating advanced sensor measurement technology, communication technology, information technology, computer technology and control technology is an important way to reach these indicators.

The various model of WAIN Connector also facilitates the safety, reliable operation and intelligent transformation of power grid.



” In order to meet the heavy-current and high-voltage requirements in power generation, WAIN provides HD HDD series and H version shell to build a secure and stable system.



» HD HDD High-Density Inserts

- Safe and reliable, convenient maintenance
- High density of crimping contacts, up to 216 contacts, compact structure
- Match with various kinds of hoods and housings



■ Vacuum circuit breaker



■ High-tension switch cabinet



■ Box-type substation

» Connectors in Rail transit

Due to further specialization of labor and requirements for convenient maintenance, the modular design of components in the railway traffic technology is being attached with more and more attention. WAIN Connector provides a complete solution for different electrical connections among all kinds of components, ensuring the safe and reliable coordinated operation of each component in various environments.



» HM Series Inserts: Flexible Combination

- Modular structure with high flexibility.
- Compact structure saves space.
- Connectors can be assembled according to special requirement.





■ Jumper wire



■ Coupling end



■ Coupling end



■ Hauling system

Product applications | **Automatization**



” WAIN uses single connector to achieve power and signal transmission so that robot wiring is more reasonable and engineering application can be carried out with high efficiency.



» Use the least space to realize the automation

In the development of modern automation technology, flexibility is a very important indicator, including flexibility and convenience of installation, use, production and commissioning.

WAIN' s HE, HEE, HK, HM and other series, along with hoods and housings with various degrees of protection, cable outlets and locking levers, can satisfy the requirements for space and electrical connection.



» HM Combined suite

- Modular structure
- Universality, reducing inventory
- Realize the power and signal transmission in the least space
- Meet electrical or signal connecting requirements in different fields and for different purposes



■ Outer join



■ Control system



■ Outer join

Product applications | Machinery

» Connector in machinery

In machinery manufacturing field, due to the diversified equipment and space requirements, light, gas and other media are also needed to be transmitted in some cases, besides weak current and strong current.

WAIN Connector provides integral solutions for this; it not only has many electrical connectors, but also has connectors for other media (such as pneumatic connector). It can satisfy different applications of various kinds of equipment, and simultaneously connect electrical circuit and gas circuit in a connector if necessary.

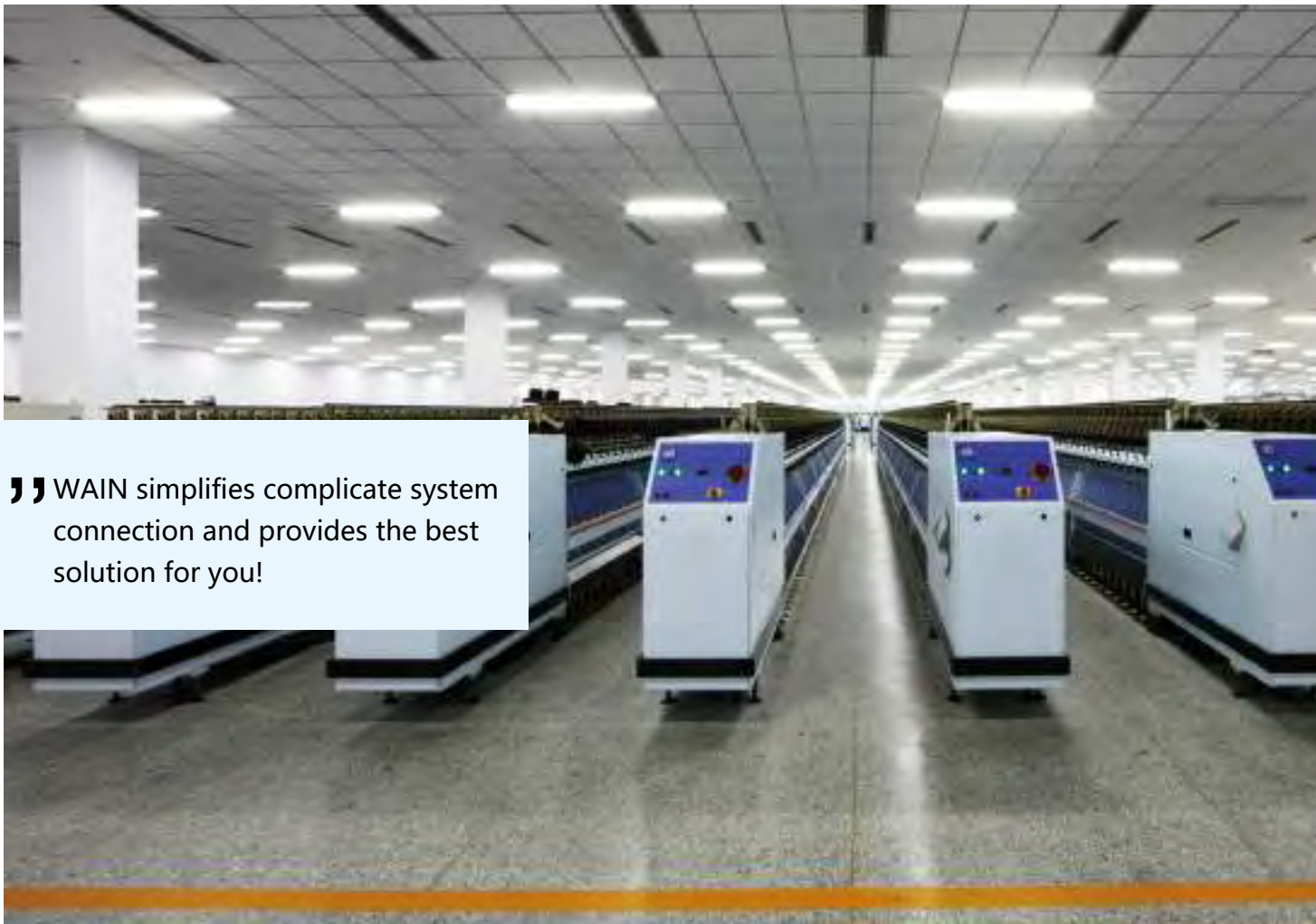

» WAIN simplifies complicate system connection and provides the best solution for you!



» HQ compact connectors

- Convenient maintenance
- Compact design
- Match pressure tight or EMC hoods/housings

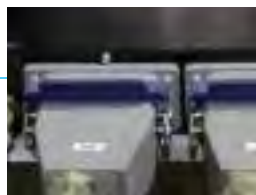

» Connector in engineering machinery

The future demands for diversification, high rise, beautiful appearance, energy conservation and environmental protection in construction industry will absolutely promote the development of engineering machinery.

WAIN Connector, boasting of dozens of series, thousand of models, strong current connection up to 650A and shells with IP65/IP68 protection grade, provides reliable electrical connection for the high-end and intelligent development of construction machinery.

*The hoods/housings developed by WAIN for harsh environment reach a salt-spray protection of 500 hours. Compared with similar product around the world, it has more excellent protection capability.

*Airtightness of fluororubber has formed standard adapter of WAIN product. Therefore, it can satisfy protection requirement under chemistry and chemical engineering environment.



» In the harsh environment, WAIN offers high protection grade connection scheme for the stability of the engineering machinery .



HEE High density connectors

- High density of crimping contacts , up to 92 pins
- Polarised insert
- Contacts available with either hard silver plated or hard gold plated surface
- Various degrees of protection and cable entries for the hoods
- Airtightness of fluororubber
- Locking levers made of stainless steel



■ Engineering machinery



■ Engineering machinery



■ Engineering machinery

Explain for Designation

Hood

W24B-TE-4B-M25

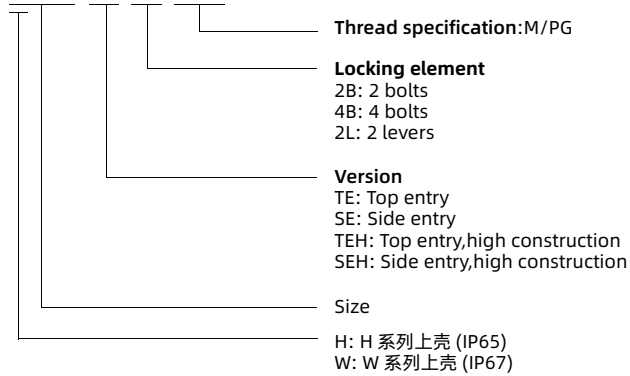

Housing

W24B-BK-4B-CV

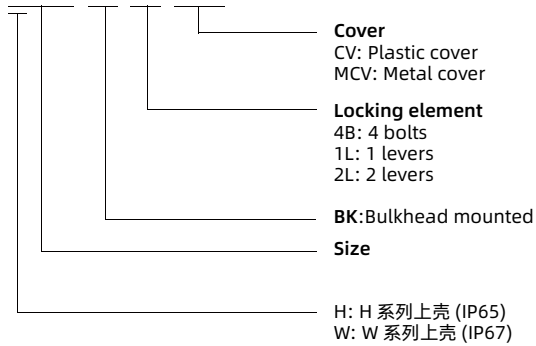

W24B-SF-1L-CV-M25

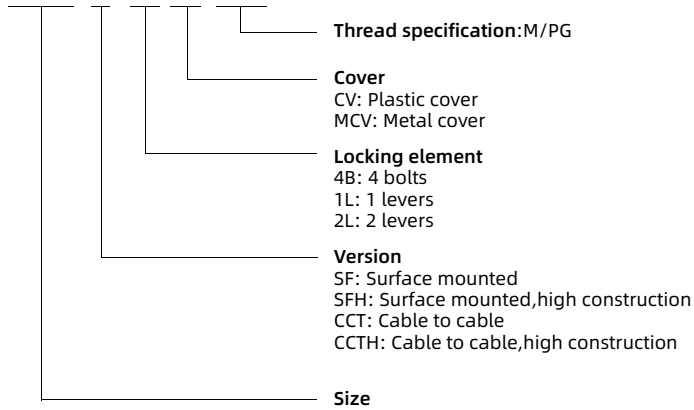

Insert

HE-024-M

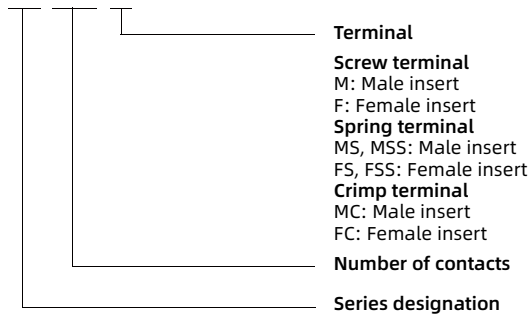

Parts of the heavy duty connector

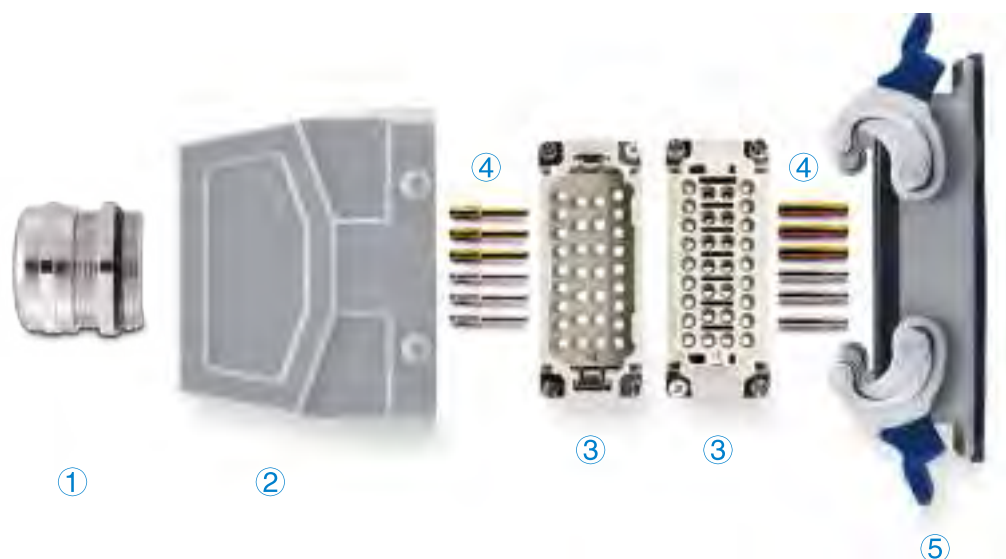









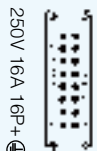

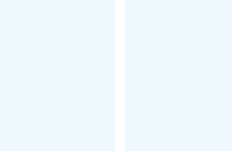

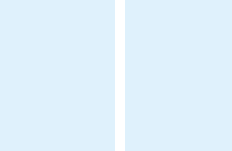
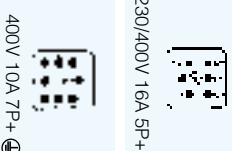

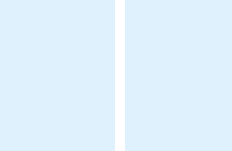
- ① **Cable gland**
Nylon or brass nickel plated
Universal cable glands
Cable gland with normal or multiple seal
Other Cable gland
- ② **Hoods**
Low or high construction
Top or side cable ent
2 bolts or 4 bolts or 2 locking levers
- ③ **Male insert or Female insert**
Screw terminal
Crimp terminal
Cage-clamp terminal
Spring terminal
- ④ **Crimp contacts (only for crimp connection insert)**
Golden plated or silver plated
Rated current: 5A, 10A, 16A, 40A, 70A, 100A, 200A, 350A, 650A
- ⑤ **Housings**
Bulkhead mounting or surface mounting or cable to cable
Low or high construction
1 or 2 locking levers or 4 bolts
With or without thermoplastic/metal covers

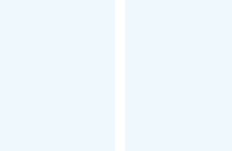
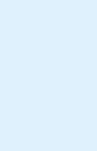
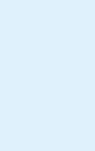
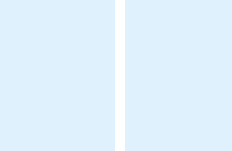
Except standard hoods/housings, special hoods/housings with high protection level(IP68) and EMC screening are also available for clients.

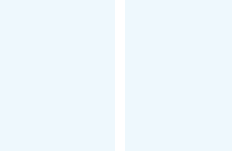
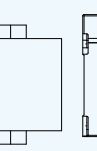
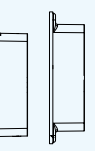
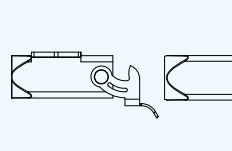
* For customized requirement, please contact us.

Product overview

Hoods	Inserts		Housings
32A	16A	10A	
suitable for 2 Inserts of size 16 A			
			
			
			
			
			
			
			
			

Hoods		Inserts							Housings
6B		HE Series Crimp terminal Screw terminal Spring terminal	HVE/HVES Series Screw terminal Spring terminal	HEE Series Crimp terminal	HD/HDD Series Crimp terminal	HSB Series Screw terminal	HK Series Screw terminal	HM Series Crimp terminal Screw terminal Spring terminal	
		500V 16A 6P+ ⊕	830V 16A 3+2P+ ⊕	500V 16A 18P+ ⊕	250V 10A 24P+ ⊕		400/250V 16/10A 8/24P+ ⊕	2 modules 	
10B		HE Series Crimp terminal Screw terminal Spring terminal	HVE/HVES Series Screw terminal Spring terminal	HEE Series Crimp terminal	HD/HDD Series Crimp terminal	HSB Series Screw terminal	HK Series Screw terminal	HM Series Crimp terminal Screw terminal Spring terminal	
		500V 16A 10P+ ⊕	830V 16A 6+2P+ ⊕	500V 16A 32P+ ⊕	250V 10A 42P+ ⊕		690/250V 70/16A 4/4P+ ⊕	3 modules 	
16B		HE Series Crimp terminal Screw terminal Spring terminal	HVE/HVES Series Screw terminal Spring terminal	HEE Series Crimp terminal	HD/HDD Series Crimp terminal	HSB Series Screw terminal	HK Series Screw terminal	HM Series Crimp terminal Screw terminal Spring terminal	
		500V 16A 16P+ ⊕	830V 16A 6+2P+ ⊕	500V 16A 46P+ ⊕	250V 10A 40P+ ⊕	400/690V 35A 12P+ ⊕	830/400V 80/16A 4/0P+ ⊕ 830/400V 80/16A 4/2P+ ⊕	4 modules 	
24B		HE Series Crimp terminal Screw terminal Spring terminal	HVE/HVES Series Screw terminal Spring terminal	HEE Series Crimp terminal	HD/HDD Series Crimp terminal	HSB Series Screw terminal	HK Series Screw terminal	HM Series Crimp terminal Screw terminal Spring terminal	
		500V 16A 24P+ ⊕	830V 16A 10+2P+ ⊕	500V 16A 40P+ ⊕	250V 10A 64P+ ⊕		690/160V 40/10A 6/36P+ ⊕	6 modules 	
32B		suitable for 2 inserts of size 16 B							
48B		suitable for 2 inserts of size 24 B							

Degree of Protection of Hoods/Housings







The connector's hood, housing, sealing and locking lever protect the inner components from external influences such as mechanical shocks, foreign bodies, humidity, dust, water or other fluids such as cleansing and cooling agents, oils, etc. The degree of protection the housing offers is explained in the IEC 60 529, DIN EN 60 529, standards that categorize enclosures according to foreign body and water protection.

The following table shows the different degrees of protection.

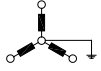
Code letters international protection		First index figure Foreign bodies protection		Second Index Figure Water protection	
IP		6		8	
Index figure	Degree of protection	Index figure	Degree of protection		
0	No protection: No protection against accidental contact, no protection against solid foreign bodies.	0	No protection against water.		
1	Protection against large foreign bodies: protection against contact with any large area by hand and against large solid foreign bodies with $\varnothing > 50\text{mm}$.	1	Drip-proof: Protection against vertical water drips.		
2	Protection against medium sized foreign bodies: protection against contact with the fingers, protection against solid foreign bodies with $\varnothing > 12\text{mm}$.	2	Drip-proof: Protection against water drips (Up to a 15° angle)		
3	Protection against small solid foreign bodies: protection against tools, wires or similar objects $\varnothing > 2.5\text{mm}$, protection against small foreign solid bodies with $\varnothing > 2.5\text{mm}$.	3	Spray-proof: Protection against diagonal water drips (Up to 60° angle)		
4	Protection against grain-shaped foreign bodies: As 3 however, $\varnothing > 1\text{mm}$.	4	Splash-proof: Protection against splashed water from all directions.		
5	Protection against injurious deposits of dust: Full protection against contact, protection against interior injurious dust deposits.	5	Hose-proof: Protection against water (out of a nozzle) from all directions.		
6	Protection against ingress dust: Total protection against contact, protection against penetration dust.	6	Protection against flooding: Protection against temporary flooding.		
		7	Protection against immersion: Protection against temporary immersion.		
		8	Water-tight: Protection against temporary Pressure.		
		9	Protected against water from high-pressure / steam jet cleaners		

Electrical engineering data

Rated impulse voltages (Table B2 of DIN EN 60 664-1)

Nominal voltage of the supply system (= rated insulation voltage of equipment)					Preferred values for the rated impulse voltage kV (1.2/50 us)			
					Overvoltage category			
					I	II	III	IV
Voltage line to earth derived from the nominal voltage of the supply system to the a.c. voltage (r.m.s. value) d.c. voltage	AC voltage (r.m.s. value) 	AC voltage   	AC voltage (r.m.s. value) d.c. voltage) 	AC voltage (r.m.s. value) d.c. voltage) 	Special protection levels	Level for electrical equipment (household and others)	Level for distribution supply systems	Input level
v	v	v	v	v				
100	66/115	66	66	-	0.5	0.8	1.5	2.5
150	120/208; 127/220;	115; 120; 127	110; 120;	220-110; 240-120	0.8	1.5	2.5	4
300	220/380; 230/400; 240/415; 260/440; 277/480;	220; 230; 240; 260; 277	220	440-220	1.5	2.5	4	6
600	347/600; 380/660; 400/690; 415/720; 480/830	347; 380; 400; 415; 440; 480; 500; 577; 600	480;	960-480	2.5	4	6	8
1000		660; 690; 720; 830; 1000	1000	-	4	6	8	12

Over-voltage category

The following categories in line with the standard IEC 60664-1

The overvoltage category is dependent on the mains voltage and the location at which the equipment is installed. It describes the maximum overvoltage resistance of a device in the event of a power supply system fault, e. g. in the event of a lightning strike. According to the relevant standards, there are 4 overvoltage categories.

Category I is equipment for connection to circuits in which measures are taken to limit transient overvoltages to an appropriately low level.

Note: Examples are protected electronic circuits

Category II is energy-consuming equipment to be supplied from the fixed installation.

Note: Examples of such equipment are appliances, portable tools and other household equipment with similar loads.

Category III is equipment in fixed installations and for cases where the reliability and the availability of the equipment is subject to special requirements.

Note: Examples of such equipment are switches in the fixed installation and equipment for industrial use with permanent connection to the fixed installation. WAN industrial connectors belong to the over-voltage type

Category IV is for use at the origin of the installation.

Note: Examples of such equipment are electricity meters and primary overcurrent protection equipment.

Electrical engineering data

Pollution degree

The following categories in line with the standard IEC 60664-1

The dimensioning of operating equipment is dependent on environmental conditions. Any pollution or contamination may give rise to conductivity that, in combination with moisture, may affect the insulating properties of the surface on which it is deposited. The pollution degree influences the design of components in terms of the creepage distance. The pollution degree is defined for exposed, unprotected insulation on the basis of environmental conditions

Pollution degree I

No pollution or only dry, non-conductive pollution occurs. The pollution has no influence, such as computer and measuring instrument rooms, for example.

Pollution degree II

Only non-conductive pollution occurs except that occasionally a temporary conductivity caused by condensation is to be expected, such as residential, sales, laboratories, precision engineering workshops, for example.

Pollution degree III

Conductive pollution occurs or dry nonconductive pollution occurs which becomes conductive due to condensation which is to be expected, such as unheated storage premises, workshops or boiler rooms, also for the electric components of assembly or mounting equipment and machine tools, for example. **WAIN heavy duty connectors are designed as standard for the Pollution Degree.**

Pollution degree IV

The pollution generates persistent conductivity caused by conductive dust or by rain or snow, such as in the environment of outdoor.

Special ruling for connectors

Subject to compliance with certain preconditions, the standard for connectors permits a lower pollution degree than that which applies to the installation as a whole. This means that in a pollution degree 3 environment, connectors may be used which are electrically rated for pollution degree 2.

Extract from DN EN 61 984, Para 6.19.2.3.

For a connector with a degree of protection IP54 or higher according to EC 60529, the insulating parts inside the enclosure may be dimensioned for a lower pollution degree, This also applies to mated connectors where enclosure is ensured by the connector housing and which may only be disengaged for test and maintenance purposes.

The conditions fulfill:

- a connector which is protected to at least IP54 acc. to IEC 60 529
- a connector which is installed in a housing and which as described in the standard is disconnected for testing and maintenance purposes only.
- a connector which is installed in a housing and which when disconnected is protected by a cap or cover to at least IP54.
- a connector located inside a switching cabinet to at least IP54.

Note: These conditions do not extend to connectors which when disconnected remain exposed to the industrial atmosphere for an indefinite period.

Typical applications in which to choose pollution degree 2 connectors:

- A connector serving a drive motor which is disconnected only for the purpose of replacing a defective motor, even when the plant or system otherwise calls for pollution degree 3.
- Connectors located inside a switching cabinet to IP54, In such cases, it is even possible to dispense with the IP54 housings of the connectors themselves,
- Connectors serving a machine of modular design which are disconnected for transport purposes only and enable rapid erection and reliable commissioning. In this case, protective covers or adequate packing must be provided to ensure that the connectors are not affected by pollution/contamination.

Terminations technology

Screw terminal

Advantages

Wide scope of applicable wire specification;
 No special tool needed;
 Protection plate of wire is available;
 A single hole can be connected to several wires at the same time if necessary;
 Insert has contact pins itself, easy to reduce inventory.

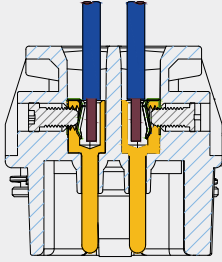

Screw terminal is accord to VDE 0609/EN 60 999. Test dimensions and tightening torques are shown in the list following.

Dimensions and tightening torque of screw terminals.

Wire gauge (mm ²)	1.5	2.5	4	6	10	16
Screw thread	M3	M3	M3.5	M4	M4	M6
Test moment of torque (Nm)	0.5	0.5	0.8	1.2	1.2	1.2*
min. pull-out for stranded wire(N)	40	50	60	80	90	100

*For fixed screws without heads

For fixed screws without heads

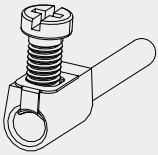

The ferrules is not necessary to use for:
 HSB series, HVE series, HK-006/12, HK-006/6

Terminals without wire protection

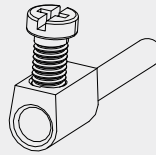

The insulation is to be removed and use the wire ferrules:
 HK-004/0, HK-004/2, HK-004/8

Screw terminal

Inserts	Wire protection		min. wire gauge		max. wire gauge		Stripping length mm
	Yes	No	mm ²	AWG	mm ²	AWG	
HA-003/HA-004		✓	0.75	18	1.5	16	4.5
HA-010/HA-016/HA-032	✓		0.75	18	2.5	14	7.5
HE Series, HVE Series	✓		0.75	18	2.5	14	7.5
HSB Series	✓		1.5	16	6	10	11.5
HK-006/6, HK-006/12(signal contacts)	✓		0.2	24	2.5	14	7.5
HK-004/2, HK-004/8(signal contacts)		✓	0.5	20	2.5	14	7.5
HK-004/0, HK-004/2, HK-004/8(power contacts)		×	1.5	16	16	6	14
HD AV Series, HE AV Series	✓		0.2	24	2.5	14	8..11

Terminations technology

Screw terminal

Recommendation of tightening torque and screwdriver types for inserts connecting with screws

Screw type	Screws classification	Inserts	tightening torque recommendation(Nm)	tightening torque recomma (Lbft)	screwdriver types recommendation
M3	screw terminal	HA-003/HA-004、HQ-005/acHQ-007/HQ-012 (PE)	0.25	0.20	cross screwdr PH0
	screw terminal	HD AV, HE AV, HK-006/6(signal pin), HK-006/12 (signal pin)	0.50	0.40	slot type screwdriver 0.5x3.0
	screw terminal	HA-010/HA-016/HA-032, HVE, HE, HME-005, HWK-006/6(signal pin)	0.50	0.40	slot type screwdriver 0.6x3.5 or cross screwdriver PH1
	Screws fixed on the 3A Hoods/Housings	HA-002/HA-003/HA-004、HD-007/HD-008、HQ-002/HQV-002/HQ-005/HQ-007/HQ-012	0.50	0.40	cross screwdriver PH1or cross screwdriver PH2
	Screws fixed on the H10A/H16A/H32A Hoods/Housings, HB Hoods/Housings	HA-010/HA-016/HA-032、HE、HVE、HEE、HD-015 HD-025/HD-050/HD-040/HD-064/HD-080/HD-128、HDD、HSB、HK、HWK、HKH、HE AV、HD AV	0.50	0.40	slot type screwdriver 0.6x3.5 or cross screwdriver PH1 or cross screwdriver PH2
	Coding Pin	CODE-M3、M3CODE-M3、GBUSH-M3、GPIN-M3、MGBUSH-M3、MGPIN-M3	0.50	0.40	slot type screwdriver 1x6.0
M3.5	Ground terminal	HA-010/HA-016/HA-032、HD-015/HD-025	0.80	0.60	slot type screwdriver 0.6x3.5 or cross screwdriver PH1
M4	screw terminal	HSB-006/HSB-012	1.20	0.90	slot type screwdriver 0.6x3.5 or cross screwdriver PH1
	Ground terminal	HE、HVE、HD-040/HD-064/HD-080/HD-128、HE AV、HD AV、HK-008/24、HWK-006、HK-006/6、HK-006/12、HK-008/0、HSB-006/HSB-012	1.20	0.90	slot type screwdriver 0.8x4.5 or cross screwdriver PH2
M5	screw terminal	HWK-006/6(power pin)	2.00	1.40	slot type screwdriver 0.8x4.5
	Ground terminal	HK-012/2、HKH-012/0、HK-004/0、HK-004/2、HK-004/8、HK-006/36	2.00	1.40	slot type screwdriver 0.8x4.5 or cross screwdriver PH2
M6	screw terminal	HK-004/0(power pin), HK-004/2 (power pin), HK-004/8(power pin)	the corresponding technical data please see chapter 8		slot type screwdriver 0.8x4.5
slot type screwdriver according to ISO 2380 cross screwdriver according to ISO 8764					

Increasing the tightening torque does not improve considerably the contact resistances. The torque moments were determined when optimum mechanical, thermal and electrical circumstances were given. If the recommended figures are considerably exceeded the wire or the termination can be damaged.

Terminations technology

Crimp connectio

Advantages

Applicable to vibration situation;
Density of the contact pin is high;
Nearly cold welding guarantees corrosion resistance;
Able to achieve pre-assembly of wiring harness;
The same insert can be used for different coated pins according to actual demand.

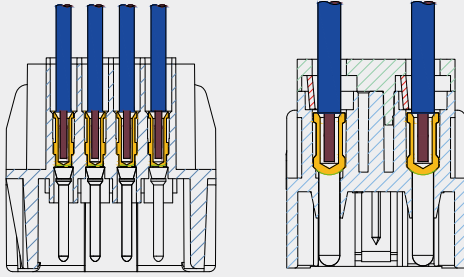

A perfect crimping can realize air tight state, and has the effect of cold welding. To achieve high-quality crimping requires the coordination of crimping parts and crimping tools, the crimped wires must match the correct specifications of crimping pieces. As long as these basic requirements are met, the user can ensure a connection with low contact resistance and high corrosion resistance.

The requirements for crimping connectors shall be in accordance with DIN EN60 352-2 as following table.

Tensile strength:

The tensile strength of the contact wire at the terminal can be used to judge the crimping quality of the conductor. The relationship between tensile strength and cross section area of conductor is defined under DIN EN60 352-2.

Using the Wain crimping tool can ensure the required tensile strength in the correct application process.

Crimping tools

The crimping tool (hand or automatic) is designed to make the connecting parts of contact or wire deform uniformly under the pressure of pliers, to ensure the uniform extension of material.

Overview inserts with crimp terminal

Wire gauge		Internal diameter Ø (mm)	Stripping length l (mm)		
(mm ²)	AWG		HD HDD R15 Modular (10A)	HE HA HvE (16A)	HC (40A)
0.14 ... 0.37	26 ... 22	0.9	8	-	-
0.5	20	1.15	8	7.5	-
0.75	18	1.3	8	7.5	-
1	18	1.45	8	7.5	-
1.5	16	1.75	8	7.5	9
2.5	14	2.25	6	7.5	9
4	12	2.85	-	7.5	9.6
6	10	3.5	-	-	9.6
10	8	4.6	-	-	15

	Conductor cross-section	Ø	Stripping length
100 A Modul	10 mm ²	4.3 mm	19.0 mm
	16 mm ²	5.5 mm	19.0 mm
	25 mm ²	7.0 mm	19.0 mm
	35 mm ²	8.2 mm	16.0 mm
HC Modular 350	35 mm ²	8.2 mm	26.0 mm
	50 mm ²	10.0 mm	28.0 mm
	70 mm ²	11.5 mm	28.0 mm
	95 mm ²	13.5 mm	30.0 mm
HC Modular 650	120 mm ²	15.5 mm	24.0 mm
	240 mm ²	22.5 mm	50.0 mm
for fine stranded wires according to IEC 60 228 class 5			

Tensile strength of crimped connections (Table 1: DIN EN 60 352-2)

Conductor cross-section		Tensile strength
mm ²	AWG	N
0.05	30	6
0.08	28	11
0.12	26	15
0.14		18
0.22	24	28
0.25		32
0.32	22	40
0.5	20	60
0.75		85
0.82	18	90
1.0		108
1.3	16	135
1.5		150
2.1	14	200
2.5		230
3.3	12	275
4.0		310
5.3	10	355
6.0		360
8.4	8	370
10.0		380

The selection of contact surface plated

Below is a table derived from actual experiences

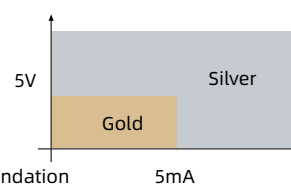

Notes: The tools for crimp terminal may influence the product quality and stability. Please select the tools recognized by our company.

Terminations technology

Axial screw terminal

Advantages

- Scope of applicable wire specification is wide;
- Special tool will not be used;
- Little space required;
- Simple operation;

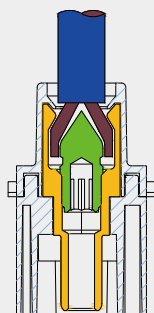

Technical notes for Axial screw terminal:

The wire gauge (sectional area) mentioned in the catalogue refers to the geometric wire gauge (sectional area) of the cable.

Background:

According to DIN VDE 0295 for cables and insulated wires, the sectional area of cables is measured according to the conductance (Ω / km) and the maximum diameter of wire. The minimum diameter of wire is not specified. For example (rated sectional area $95\text{mm}^2 \rightarrow$ actual geometric sectional area 89mm^2)

Suggestions:

If there is a big difference between the geometric cross-sectional area and the rated cross-sectional area of the cable, additional detection should be carried out when axial screw terminal is used.

Stress relief:

For safe operation, there should be enough distance between the cable and the pressure contact to ensure that the contact is not affected by radial stress. Specific stress relief designs can be found in DIN VDE 0100-520:2003-6 (refer to the table below).

Axial screw crimping instruction

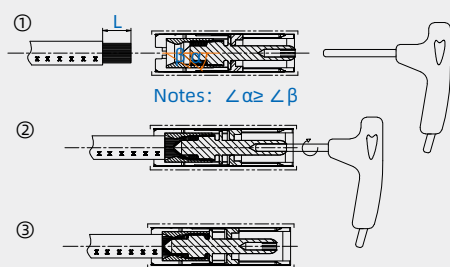

- Strip insulation from the wire, the length as per the form and insert the wire into the contact until insulation layer is flush with the wiring access of the contact. Do not twist the strands of the wire.
- Hold the wire in position and tighten the wire from the mating side by a twist driver (SW-2x40), the tightening torque reference the form.
- Complete wiring.

Outer cable diameter (mm)	Maximum fixing distance (mm)	
	horizontal	vertical
$D \leq 9$	250	400
$9 < D < 15$	300	400
$15 < D < 20$	350	450
$20 < D < 40$	400	550

Cable:

The axial screw terminal technology was developed based on DIN EN 60 228 class 5 cables (cable assembly according to DIN EN 60 228). Different cable assemblies need to be tested independently.

Assembly remarks:

Before assembly, the user must ensure that the axial taper thread completely opens the contact chamber downward. After the cable insulation is stripped, do not twist the strands, and the longest stripping length should not exceed the recommended dimension. Insert the cable completely into the connector and make direct contact with the bottom of the copper strand. Maintain the cable in this position when using the recommended tightening torque.

Maintenance of axial screw terminal:

After initial assembly, only use the recommended tightening torque once again to avoid damaging the individual wire strands.

Wire gauge (mm ²)	Stranded wires DIN EN 60 228 class 2	Fine stranded wires DIN EN 60 228 class 5	Super fine stranded wires DIN EN 60 228 class 6			
0.5	7 x 0.30	16 x 0.20	28 x 0.15	64 x 0.10	131 x 0.07	265 x 0.05
0.75	7 x 0.37	24 x 0.20	42 x 0.15	96 x 0.10	195 x 0.07	384 x 0.05
1	7 x 0.43	32 x 0.20	56 x 0.15	128 x 0.10	260 x 0.07	512 x 0.05
1.5	7 x 0.52	30 x 0.25	84 x 0.15	192 x 0.10	392 x 0.07	768 x 0.05
2.5	7 x 0.67	50 x 0.25	140 x 0.15	320 x 0.10	651 x 0.07	1280
4	7 x 0.85	56 x 0.30	224 x 0.15	512 x 0.10	1040 x 0.07	
6	7 x 1.05	84 x 0.30	192 x 0.20	768 x 0.10	1560 x 0.07	
10	7 x 1.35	80 x 0.40	320 x 0.20	1280 x 0.10	2600 x 0.07	
16	7 x 1.70	128 x 0.40	512 x 0.20	2048 x 0.10		
25	7 x 2.13	200 x 0.40	800 x 0.20	3200 x 0.10		
35	7 x 2.52	280 x 0.40	1120 x 0.20			
50	19 x 1.83	400 x 0.30	705 x 0.30			
70	19 x 2.17	356 x 0.50	990 x 0.30			
95	19 x 2.52	485 x 0.50	1340 x 0.30			
120	37 x 2.03	614 x 0.50	1690 x 0.30			
150	37 x 2.27	765 x 0.50	2123 x 0.30			
185	37 x 2.52	944 x 0.50	1470 x 0.40			
240	61 x 2.24	1225 x 0.50	1905 x 0.40			

Terminations technology

Overview inserts with axial screw terminal

Insert	Wire gauge	Stripping length	Tightening torque	Max. cable insulation diameter	Size hexagon recess	Insert dimension for cable indication (ISK)
	(mm ²)					
HK-006/12	2.5-8	2.5 mm ² : 8+1 4 mm ² : 8+1 6 mm ² : 8+1 8 mm ² : 8+1	2.5 mm ² : 1.5 4 mm ² : 1.5 6 mm ² : 2 8 mm ² : 2	6.2	2	4.7
	6-10	6 mm ² : 8+1 8 mm ² : 8+1 10 mm ² : 8+1	6 mm ² : 2 8 mm ² : 2 10 mm ² : 2	6.2	2	4.7
HK-006/6	16 - 35	13+/-1	16 mm ² : 6 25 mm ² : 7 35 mm ² : 8	11.4	4	4.9
HK-008/0	10 - 25	13+/-1	10 mm ² : 6 16 mm ² : 6 25 mm ² : 8	11.4	4	4.75
HQV-002 HQ-002/0 High Voltage	2.5-10 2.5-10	8+1 PE: 2 mm	1.8	7.3	2	5.6
200 A module without PE 200 A module with PE	25-40	25 mm ² : 16 40 mm ² : 16	25 mm ² : 8 40 mm ² : 8	12 16	5	3
200 A module without PE 200 A module with PE	40-70	40 mm ² : 16 70 mm ² : 16	40 mm ² : 9 70 mm ² : 10	12 16	5	3
100 A module	10-25	13+/-1	10 mm ² : 6 16 mm ² : 6 25 mm ² : 7	11.4	4	4.9
	16-35	13+/-1	16 mm ² : 6 25 mm ² : 7 35 mm ² : 8	11.4	4	4.9
70 A module	6-16	6 mm ² : 8+1 8 mm ² : 8+1 10 mm ² : 8+1	6 mm ² : 2 10 mm ² : 3 16 mm ² : 4	8.9	2.5	7.4
	14-22	12.5+1	14 mm ² : 4 16 mm ² : 4 22 mm ² : 5	10	2.5	5.9
40 A module	2.5-8	2.5 mm ² : 5+1 4 mm ² : 5+1 6 mm ² : 8+1 8 mm ² : 11+1	2.5 mm ² : 1.5 4 mm ² : 1.5 6 mm ² : 2 8 mm ² : 2	4 4 6 8.2	2	4.7
	6-10	6 mm ² : 8+1 10 mm ² : 11+1	6 mm ² : 2 10 mm ² : 2	6 10.5	2	4.7
Module with axial screw terminal	2.5-8 6-10	2.5 mm ² : 5+1 4 mm ² : 5+1 6 mm ² : 8+1 10 mm ² : 11+1	2.5 mm ² : 1.5 4 mm ² : 1.5 6 mm ² : 2 10 mm ² : 2	4 4 6 8.2	2	5.2
HK-003/0 straight	35-70	22	35 mm ² : 8 50 mm ² : 9 70 mm ² : 10	15	5	8.2
HK-003/0 angled	35-70	22	35 mm ² : 8 50 mm ² : 9 70 mm ² : 10	15	5	9
HK-003/2 straight	35-70	22	35 mm ² : 8 50 mm ² : 9 70 mm ² : 10	15 PE: 10	5	8.2 PE: 7.2
HK-003/2 angled	35-70	22	35 mm ² : 8 50 mm ² : 9 70 mm ² : 10	15 PE: 10	5	9.0
HC Modular 650	70-120	23+2	70 mm ² : 12 95 mm ² : 14 120 mm ² : 16	26.5	8	28
	150-185	23+2	150 mm ² : 17 185 mm ² : 18	26.5	8	28

Terminations technology

Spring terminal

Advantages

No special tool needed;
Applicable to vibration situation;
Insert has contact pins itself, easy to reduce inventory.

Spring terminal

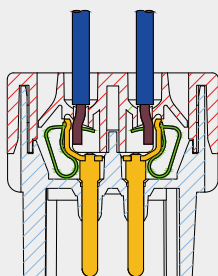

Double spring connection

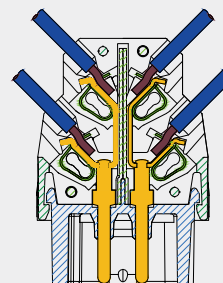

Spring terminal-connection step

Screwdriver width: 3.0 x 0.5 mm ①

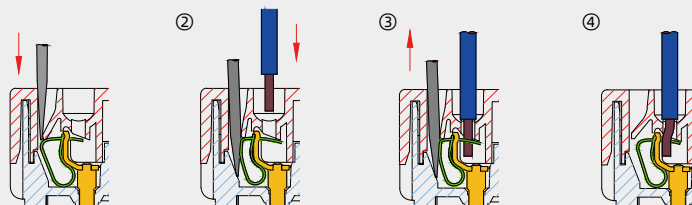

Inserts	max. wire gauge		Stripping length
	(mm ²)	AWG	l (mm)
HE Spring terminal, HVE Spring terminal	0.14 ... 2.5	26 ... 14	7 ... 9
HE Double spring connection	0.14 ... 2.5	26 ... 14	9 ... 11
HK-004/4	0.14 ... 2.5	26 ... 14	7 ... 9
HME-005-MS/FS	0.14 ... 2.5	26 ... 14	7 ... 9

Wrap terminal

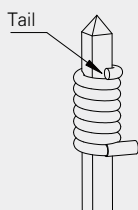

The characteristic of wrap terminal:

Solderless wrap connection technology, is to use a special tool-winding device, exerts a pulling force to the single unit solid bare wire, make it according to the prescribed number of turns in a tightly ling edges

at the terminal, so that the wire and the terminal form firm joints technology, so as to achieve a reliable electrical connection. It is different from screw connection, welding, crimping, piercing connection way.

Advantage:

Wrap connection has more advantage than solder connection, see the following ;

- ① Higher reliability, longer working life;
- ② The junction is durable, anti-fatigue, corrosion resistance;
- ③ Production quality is stable, neat appearance, easier operation, and eliminate the virtual welding problems of the solder connection;
- ④ Achieve high density mounting and product miniaturization.
- ⑤ Reduce manufacture costs and improve work efficiency.

Terminations technology

Spring terminal

HE push spring insert

Characteristics of the product:

The product can be connected and disassembled in limited space without special tool. Installation and disassembly can't be disturbed by tools, operation is convenient; Furthermore, during connection and disassembly, the hole can be opened through pushing the corresponding lever. To make it more efficient, all the holes can be opened with a slotted screwdriver simultaneously. The tool is not contacted to the conductor while operating, therefore it avoids electric shock.

Assembly instructions

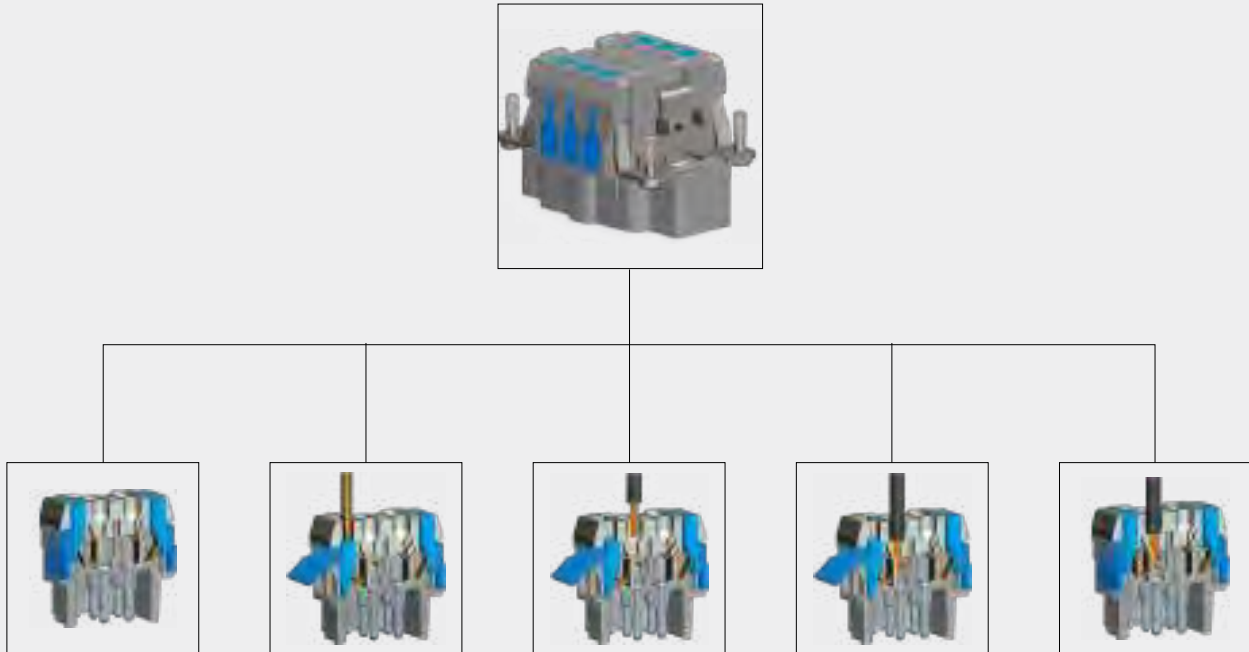

step 1: Strip the insulate layer by 9-11mm;

step 2: Using slotted screwdriver of spec. 0.5*3 to insert into groove of rectangle pushing lever, and push to the bottom, to let the driving lever tilt out. At this moment the spring stabilizes at opening condition.

step 3: Insert striped wire/cable into the round hole.

step 4: Reset the driving lever until hearing the "bang", which indicates the pushing lever automatically reset and the spring shut, the wire/cable and contact are connected securely.

step 5: Installation is completed.

Tools

HE B Spring open machine¹⁾



Description	Designation	Order NO.
for all HE B spring inserts	SOM01	198 001 003 0008

1) It can open all the shrapnel windows of insert at one time; suitable for using in mass assembly, greatly improving the efficiency of the connection.

Hoods/Housings

Screw tightening torque

Recommended tightening torque for bulkhead mounted housings

Series	Number of screws	Size of screws	Recommended Tightening torque (Nm)	Remarks
H3A	2	M 3	0.8 ... 1.0	Gasket
H10A / 16A	4	M 3	0.8 ... 1.0	Gasket
H32A	4	M 4	0.8 ... 1.0	Gasket
H6B / H10B / H16B / H24B	4	M 4	0.8 ... 1.0	Gasket
H32B	4	M 5	min. 2.5	Gasket
H48B	4	M 6	min. 3.0	O-ring
HP3A	2	M 4	min. 1.0	O-ring
HP6B / HP10B / HP16B / HP24B	4	M 6	min. 3.0	O-ring
HP6B/H / HP10B/H / HP16B/H / HP24B/H	4	M 6	min. 3.0	O-ring

To offer safe protection the surface condition for mounting panel should be according to DIN 4766:

Waviness ≤ 0.2 mm on 200 mm distance

Roughness $R_a \leq 16$ μm

HA SERIES

Compact standard connector



HA SERIES The slim inserts

Technical characteristics

Specifications	DIN EN 60 664 DIN EN 61 984
Approvals	
Inserts	
Number of contacts	3,4,10,16,32(2X16)+PE
Electrical data acc. to EN 61 984	
HA-002/HA-003/HA-004	
-Rated current	10A
-Rated voltage conductor-ground	230V
-Rated voltage conductor-conductor	400V
-Rated impulse voltage	4kV
-Pollution degree	3
-or	10A 250V 4kV 3
HA-010/HA-016	
-Rated current	16A
-Rated voltage	250V
-Rated impulse voltage	4kV
-Pollution degree	3
-Pollution degree 2 also	16A 250V/400V 4kV 2
Rated voltage acc. to UL	600V
Insulation resistance	$\geq 10^{10}\Omega$
Material	polycarbonate
Limiting temperatures	-40°C ...+125°C
Flammability acc. to UL 94	V0
Mechanical working life (mating cycles)	≥ 500
Contacts	
Material	copper alloy
Surface	hard-gold plated hard-silver plated
Contact resistance	$\leq 1m\Omega$
Screw terminal	
-Wire gauge	0.75-1.5mm ² (HA-003/004) 0.75-2.5mm ² (HA-010/016) 0.75-2.5mm ² (HA-003-M/F-V2)
- AWG	18-16 (HA-003/004) 18-14 (HA-010/016)
- Tightening/Test torque	0.25Nm (HA-003/004) or 0.5Nm (HA-010/016)
Crimp terminal	
-Wire gauge	0.14-4.0mm ²
-AWG	26-12
Spring terminal	
-Wire gauge	0.14-2.5mm ² (Not suitable for connecting terminal) 26-14
-AWG	
Spring terminal(Quick-in)	
-Wire gauge	20-14
-AWG	10 \pm 0.5mm
-Stripping length	$\leq 3m\Omega$
-Contact resistance	

Current carrying capacity

The current carrying is limited by maximum temperature of materials for inserts and contacts including terminals

Control and test procedures according to DIN EN 60512-5

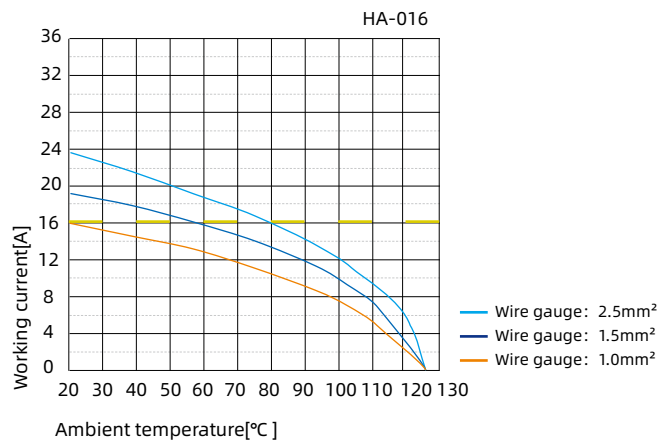
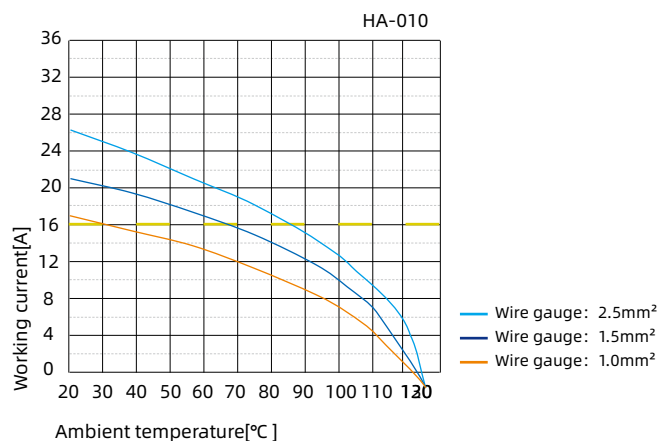
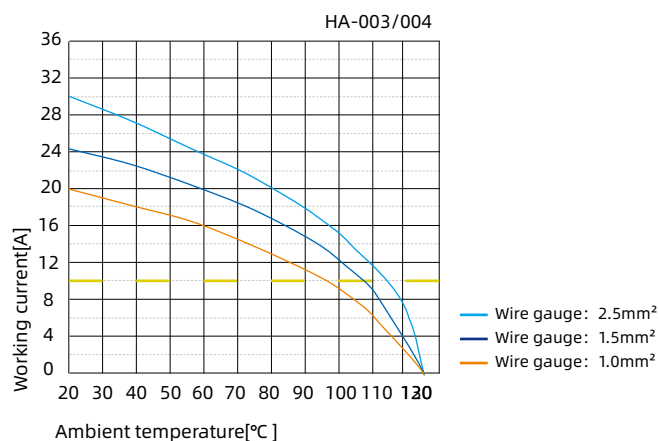

HA-003/004 The slim inserts

230/400V 10A 3/4+ ⊕



Inserts

Hoods/Housings: size 3A, please find the details on page 15-06-15-16.1.

Screw terminal



Insert	Designation	Order No.
Male	HA-003-M	121 003 011 0001
Female	HA-003-F	121 003 021 0001
Male	HA-003-M-V2	121 003 011 0505
Female	HA-003-F-V2	121 003 021 0505
Male	HA-004-M-V2	121 004 011 0002
Female	HA-004-F-V2	121 004 021 0002

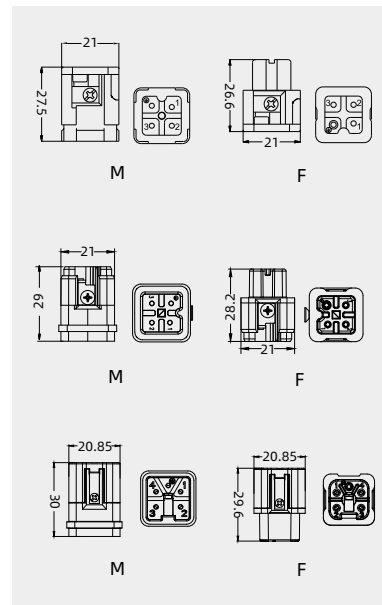

Coding element



Description	Designation	Order No.
coding, pokayoke	CODE-Q3	198 002 005 0034

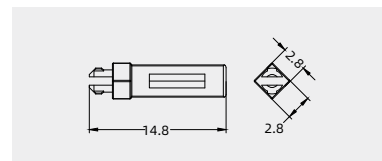

Suitable for HA-003-M/F-V2

Spring terminal, See P00-14 for the structural characteristics of spring.



Insert	Designation	Order No.
Male	HA-002-MS	121 002 012 0001
Female	HA-002-FS	121 002 022 0001
Male	HA-003-MS	121 003 012 0001
Female	HA-003-FS	121 003 022 0001
Male	HA-004-MS	121 004 012 0001
Female	HA-004-FS	121 004 022 0001

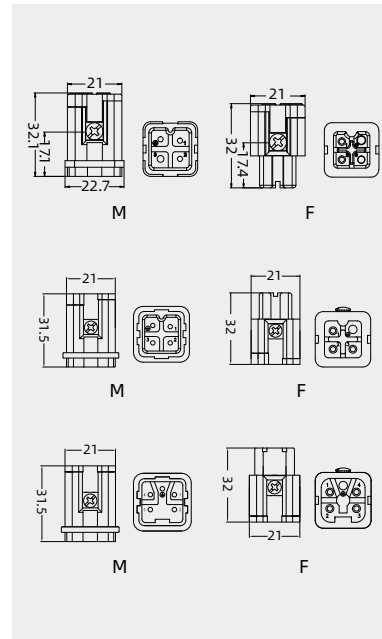

HA-003/004 Quick-in module

230/400V 10A 3/4+ ⊕

Inserts



Hoods/Housings: size 3A, please find the details on page 15-06-15-16.1.

Spring terminal(Quick-in)



Insert	Designation	Order No.
Male	HA-003-MQ	121 003 001 0001
Female	HA-003-FQ	121 003 002 0001
Male	HA-004-MQ	121 004 001 0001
Female	HA-004-FQ	121 004 002 0001

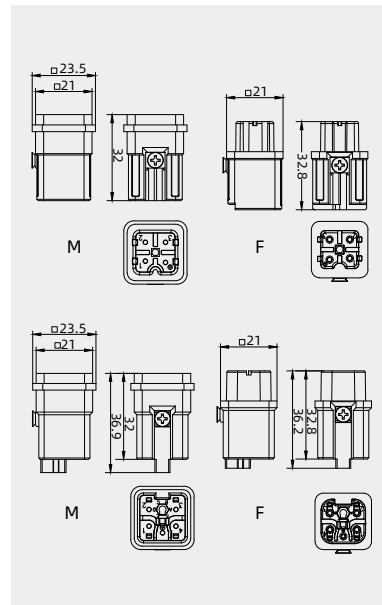

Coding element



Description	Designation	Order No.
coding、pokayoke	CODE-Q3	198 002 005 0034

Suitable for HA-003-MQ/FQ

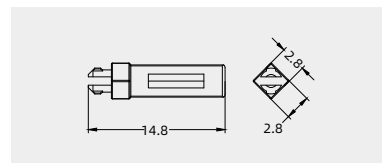

Coding element



Description	Designation	Order No.
coding、pokayoke	CODE-Q5	198 002 005 0036

Suitable for HA-004-MQ/FQ

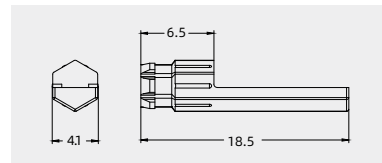

HA-004-M-V2/HA-004-F-V2 Features

Step 1: wire from the top, lock the side screw

Step 2: close the cover

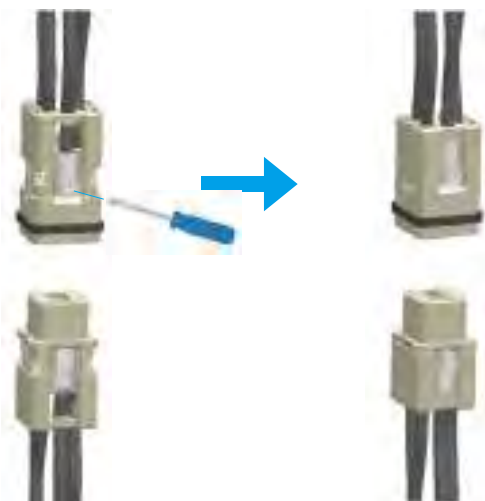

The feature of structure:

- ① .Cover was added;
- ② .Top entry, side screw locking
- ③ .Low insert height

The innovation:

- ① .The insert is separated from the shell by the cover. That ensures enough creepage distance and reliable electrical property;
- ② .When it is side entry, the cable have to be bent to an angle of 90 degree and go upward, the top entry could avoid the bend of cable and have convenient assembly
- ③ .Compact structure saves space.

HA-010 The slim inserts

250V 16A 10+



Inserts

Hoods/Housings: size 10A, please find the details on page 15-17~15-18.1.

Screw terminal



Insert	Designation	Order No.
Male	HA-010-M	121 010 011 0001
Female	HA-010-F	121 010 021 0001
Male	HA-010-M/B ¹⁾	121 010 011 0503
Female	HA-010-F/B ¹⁾	121 010 021 0503

1) /B stands for wiring with cable protecting(details see page 00-09)

Crimp terminal

Order crimp contacts separately



Insert	Designation	Order No.
Male	HA-010-MC	121 010 010 0001
Female	HA-010-FC	121 010 020 0001

Spring terminal, See P00-14 for the structural characteristics of spring.



Insert	Designation	Order No.
Male	HA-010-MS	121 010 012 0001
Female	HA-010-FS	121 010 022 0001

1) Distance for contact max. 24 mm

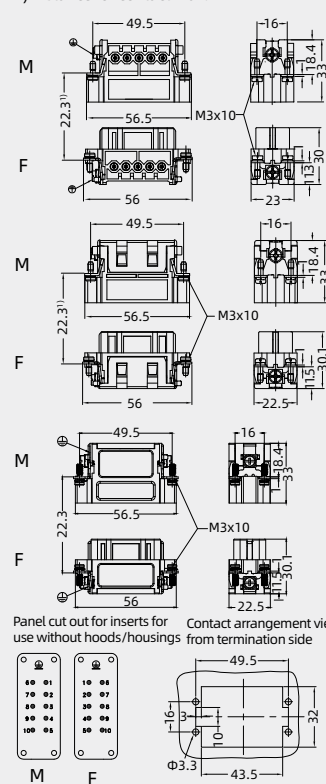

Crimp contacts

Crimp contacts 16A

Contact resistance ≤ 1mΩ silver plated



gold plated



Male	Order No.	Female	Order No.
CESM-0.37	101 019 110 0301	CESF-0.37	101 019 120 0301
CESM-0.50	101 019 110 0401	CESF-0.50	101 019 120 0401
CESM-0.75	101 019 110 0601	CESF-0.75	101 019 120 0601
CESM-1.0	101 019 110 0801	CESF-1.0	101 019 120 0801
CESM-1.5	101 019 110 0901	CESF-1.5	101 019 120 0901
CESM-2.5	101 019 110 1001	CESF-2.5	101 019 120 1001
CESM-3.0	101 019 110 1101	CESF-3.0	101 019 120 1101
CESM-4.0	101 019 110 1201	CESF-4.0	101 019 120 1201
CEGM-0.37	101 019 210 0301	CEGF-0.37	101 019 220 0301
CEGM-0.50	101 019 210 0401	CEGF-0.50	101 019 220 0401
CEGM-0.75	101 019 210 0601	CEGF-0.75	101 019 220 0601
CEGM-1.0	101 019 210 0801	CEGF-1.0	101 019 220 0801
CEGM-1.5	101 019 210 0901	CEGF-1.5	101 019 220 0901
CEGM-2.5	101 019 210 1001	CEGF-2.5	101 019 220 1001
CEGM-3.0	101 019 210 1101	CEGF-3.0	101 019 220 1101
CEGM-4.0	101 019 210 1201	CEGF-4.0	101 019 220 1201

More crimp contacts 16A see P13-04.

Tools

Crimping tool



Contact removal tool



Wire gauge	Designation	Order No.
0.14-4mm ²	TL02G	198 001 001 0011

Wire gauge: 0.14-0.37mm² please select TL02 Crimping tool.

Application	Designation	Order No.
for crimp contacts 16A	TL01	198 001 000 0002

More tools detail please find the page 32-03~32-06.

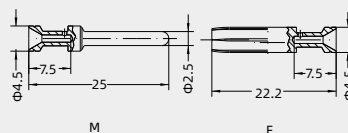

Identification	Wire gauge	Stripping length	
no groove	0.14-0.37 mm ²	AWG 26-22	7.5mm
no groove	0.5 mm ²	AWG 20	7.5mm
1 groove	0.75 mm ²	AWG 18	7.5mm
1 groove	1 mm ²	AWG 18	7.5mm
2 grooves	1.5 mm ²	AWG 16	7.5mm
3 grooves	2.5 mm ²	AWG 14	7.5mm
wide groove	3 mm ²	AWG 12	7.5mm
no groove	4 mm ²	AWG 12	7.5mm

When the wire gauge is less than 0.75mm², it's better to use the auxiliary pin assembly tool TL15.

Notes: The tools for crimp terminal may influence the product quality and stability. Please select the tools recognized by our company.

HA-016 The slim inserts

250V 16A 16+ 



Inserts

Hoods/Housings: size 16A, please find the details on page 15-19~15-20.

Screw terminal



Insert	Designation	Order No.
Male	HA-016-M	121 016 011 0001
Female	HA-016-F	121 016 021 0001
Male	HA-016-M/B ¹⁾	121 016 011 0505
Female	HA-016-F/B ¹⁾	121 016 021 0505

1) /B stands for wiring with cable protecting(details see page 00-09)

Crimp terminal

Order crimp contacts separately



Insert	Designation	Order No.
Male	HA-016-MC	121 016 010 0001
Female	HA-016-FC	121 016 020 0001

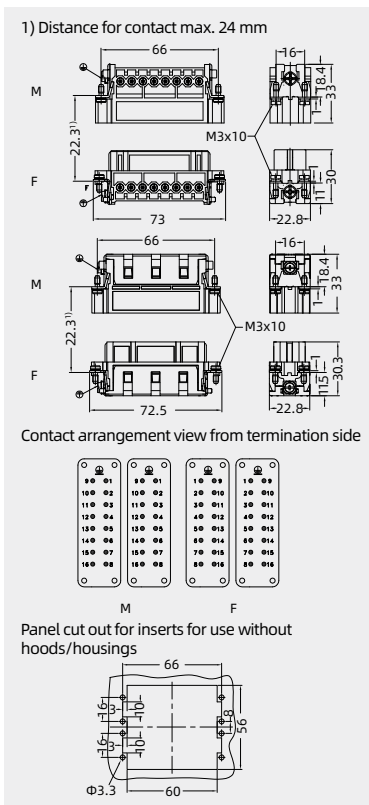

Crimp contacts

Crimp contacts 16A

Contact resistance $\leq 1\text{m}\Omega$
silver plated



gold plated



Male	Order No.	Female	Order No.
CESM-0.37	101 019 110 0301	CESF-0.37	101 019 120 0301
CESM-0.50	101 019 110 0401	CESF-0.50	101 019 120 0401
CESM-0.75	101 019 110 0601	CESF-0.75	101 019 120 0601
CESM-1.0	101 019 110 0801	CESF-1.0	101 019 120 0801
CESM-1.5	101 019 110 0901	CESF-1.5	101 019 120 0901
CESM-2.5	101 019 110 1001	CESF-2.5	101 019 120 1001
CESM-3.0	101 019 110 1101	CESF-3.0	101 019 120 1101
CESM-4.0	101 019 110 1201	CESF-4.0	101 019 120 1201

Male	Order No.	Female	Order No.
CEGM-0.37	101 019 210 0301	CEGF-0.37	101 019 220 0301
CEGM-0.50	101 019 210 0401	CEGF-0.50	101 019 220 0401
CEGM-0.75	101 019 210 0601	CEGF-0.75	101 019 220 0601
CEGM-1.0	101 019 210 0801	CEGF-1.0	101 019 220 0801
CEGM-1.5	101 019 210 0901	CEGF-1.5	101 019 220 0901
CEGM-2.5	101 019 210 1001	CEGF-2.5	101 019 220 1001
CEGM-3.0	101 019 210 1101	CEGF-3.0	101 019 220 1101
CEGM-4.0	101 019 210 1201	CEGF-4.0	101 019 220 1201

More crimp contacts 16A see P13-04.

Tools

Crimping tool



Contact removal tool



Wire gauge	Designation	Order No.
0.14-4mm ²	TL02G	198 001 001 0011

Wire gauge: 0.14-0.37mm² please select TL02 Crimping tool.

Application	Designation	Order No.
for crimp contacts 16A	TL01	198 001 000 0002

More tools detail please find the page 32-03~32-06.

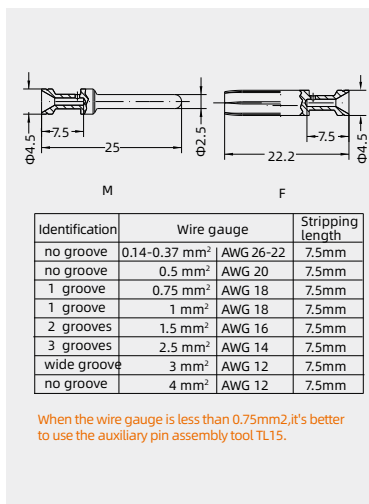

Notes: The tools for crimp terminal may influence the product quality and stability. Please select the tools recognized by our company.

HA-032 The slim inserts

250V 16A 32+ 



Inserts

Hoods/Housings: size 32A, please find the details on page 15-21~15-24.

Screw terminal



Insert	Designation	Order No.
Male	HA-016-M	121 016 011 0001
	HA-016-M(17-32)	121 016 011 0002
Female	HA-016-F	121 016 021 0001
	HA-016-F(17-32)	121 016 021 0002
Male	HA-016-M/B ¹⁾	121 016 011 0505
	HA-016-M/B(17-32) ¹⁾	121 016 011 0504
Female	HA-016-F/B ¹⁾	121 016 021 0505
	HA-016-F/B(17-32) ¹⁾	121 016 021 0504

1). /B stands for wiring with cable protecting (details see page 00-09)

Crimp terminal

Order crimp contacts separately



Insert	Designation	Order No.
Male	HA-016-MC	121 016 010 0001
	HA-016-MC(17-32)	121 016 010 0002
Female	HA-016-FC	121 016 020 0001
	HA-016-FC(17-32)	121 016 020 0002

Crimp contacts

Crimp contacts 16A

Contact resistance ≤ 1mΩ silver plated



gold plated



More crimp contacts 16A see P13-04.

Tools

Crimping tool



Contact removal tool



Male	Order No.	Female	Order No.
CESM-0.37	101 019 110 0301	CESF-0.37	101 019 120 0301
CESM-0.50	101 019 110 0401	CESF-0.50	101 019 120 0401
CESM-0.75	101 019 110 0601	CESF-0.75	101 019 120 0601
CESM-1.0	101 019 110 0801	CESF-1.0	101 019 120 0801
CESM-1.5	101 019 110 0901	CESF-1.5	101 019 120 0901
CESM-2.5	101 019 110 1001	CESF-2.5	101 019 120 1001
CESM-3.0	101 019 110 1101	CESF-3.0	101 019 120 1101
CESM-4.0	101 019 110 1201	CESF-4.0	101 019 120 1201
CEGM-0.37	101 019 210 0301	CEGF-0.37	101 019 220 0301
CEGM-0.50	101 019 210 0401	CEGF-0.50	101 019 220 0401
CEGM-0.75	101 019 210 0601	CEGF-0.75	101 019 220 0601
CEGM-1.0	101 019 210 0801	CEGF-1.0	101 019 220 0801
CEGM-1.5	101 019 210 0901	CEGF-1.5	101 019 220 0901
CEGM-2.5	101 019 210 1001	CEGF-2.5	101 019 220 1001
CEGM-3.0	101 019 210 1101	CEGF-3.0	101 019 220 1101
CEGM-4.0	101 019 210 1201	CEGF-4.0	101 019 220 1201

Wire gauge	Designation	Order No.
0.14-4mm ²	TL02G	198 001 001 0011
Wire gauge: 0.14-0.37mm ² please select TL02 Crimping tool.		
Application	Designation	Order No.
for crimp contacts 16A	TL01	198 001 000 0002

More tools detail please find the page 32-03~32-06.

Notes: The tools for crimp terminal may influence the product quality and stability. Please select the tools recognized by our company.

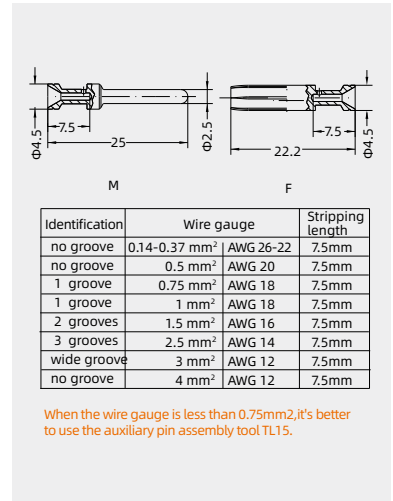
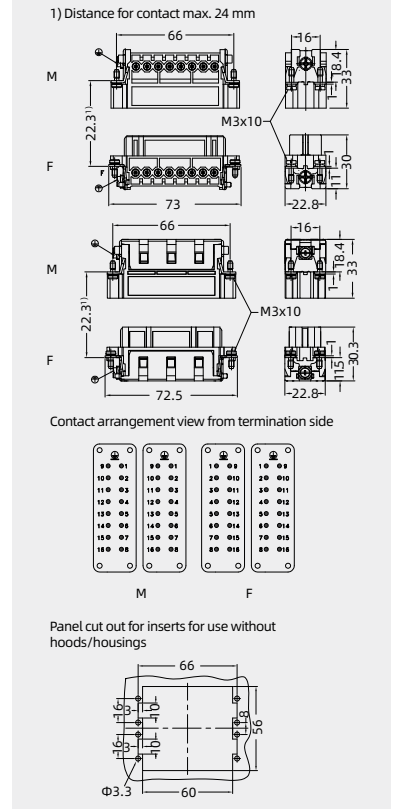

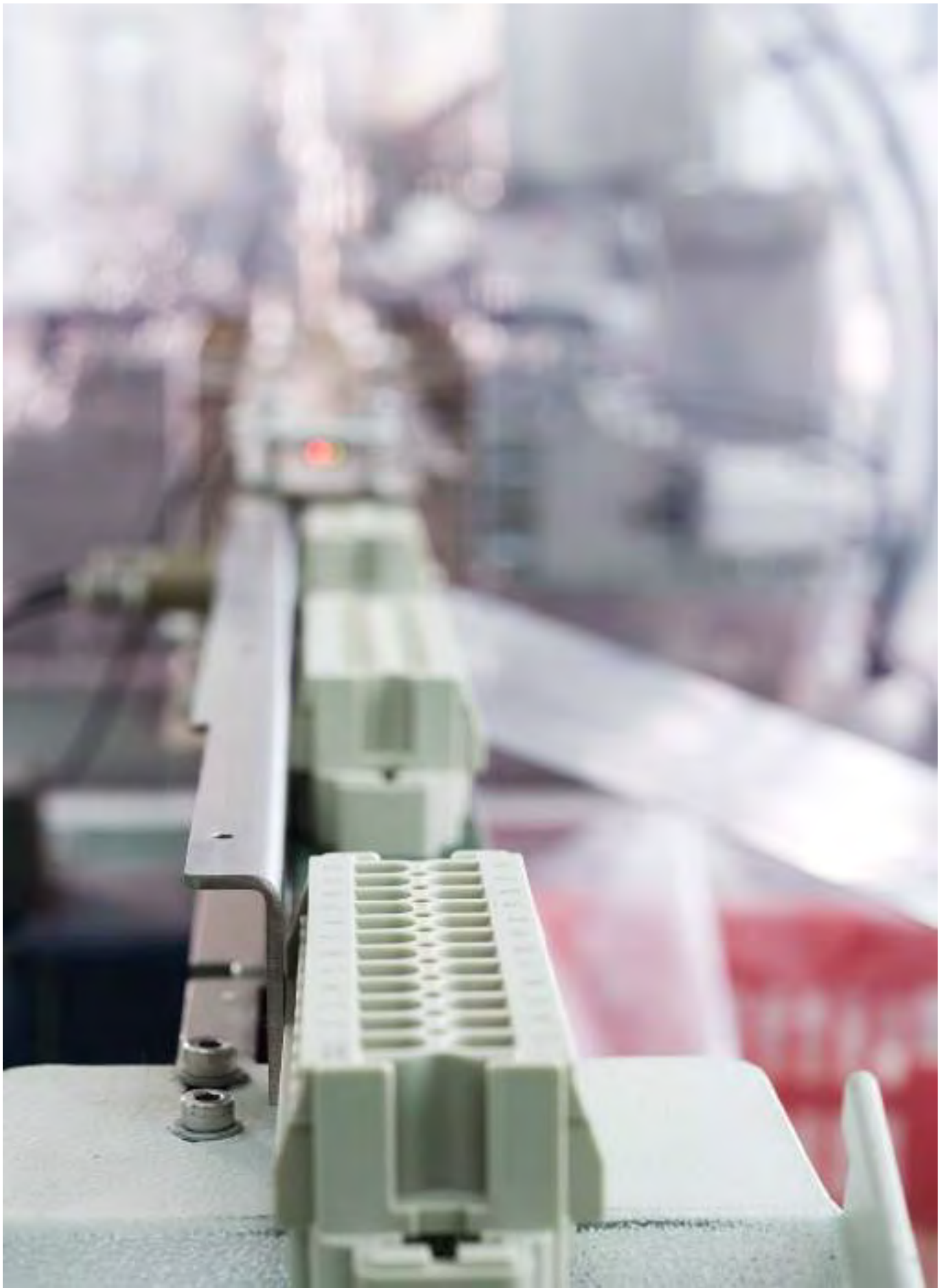

HE SERIES

Standard products



HE SERIES Standard inserts

Technical characteristics

Specifications	DIN EN 60 664 DIN EN 61 984
Approvals	
Inserts	
Electrical data acc. to EN 61 984	
-Rated current	16A
-Rated voltage	500V
-Rated impulse voltage	6kV
-Pollution degree	3
-Pollution degree 2 also	16A 400/690V 6kV 2
Rated voltage acc. to UL	600V
Insulation resistance	$\geq 10^{10}\Omega$
Material	polycarbonate
Limiting temperatures	-40°C ...+125°C
Flammability acc. to UL 94	V0
Mechanical working life(mating cycles)	≥ 500
Contacts	
Material	copper alloy
Surface	hard-gold plated hard-silver plated
Contact resistance	$\leq 1m\Omega$
Screw terminal	
-Wire gauge	0.75-2.5mm ²
-AWG	18-14
-Tightening/Test torque	0.5Nm
-Stripping length	7.0mm
Crimp terminal	
-Wire gauge	0.14-4.0mm ²
-AWG	26-12
-Stripping length	7.5mm
Spring terminal	
-Wire gauge	0.14-2.5mm ²
-AWG	26-14
-Stripping length	7-9mm
Spring terminal(Quick-in)	
-Wire gauge	0.5-2.5mm ²
-AWG	20-14
-Stripping length	9-10mm
-Contact resistance	$\leq 3m\Omega$

Current carrying capacity

The current carrying is limited by maximum temperature of materials for inserts and contacts including terminals

Control and test procedures according to DIN EN 60512-5

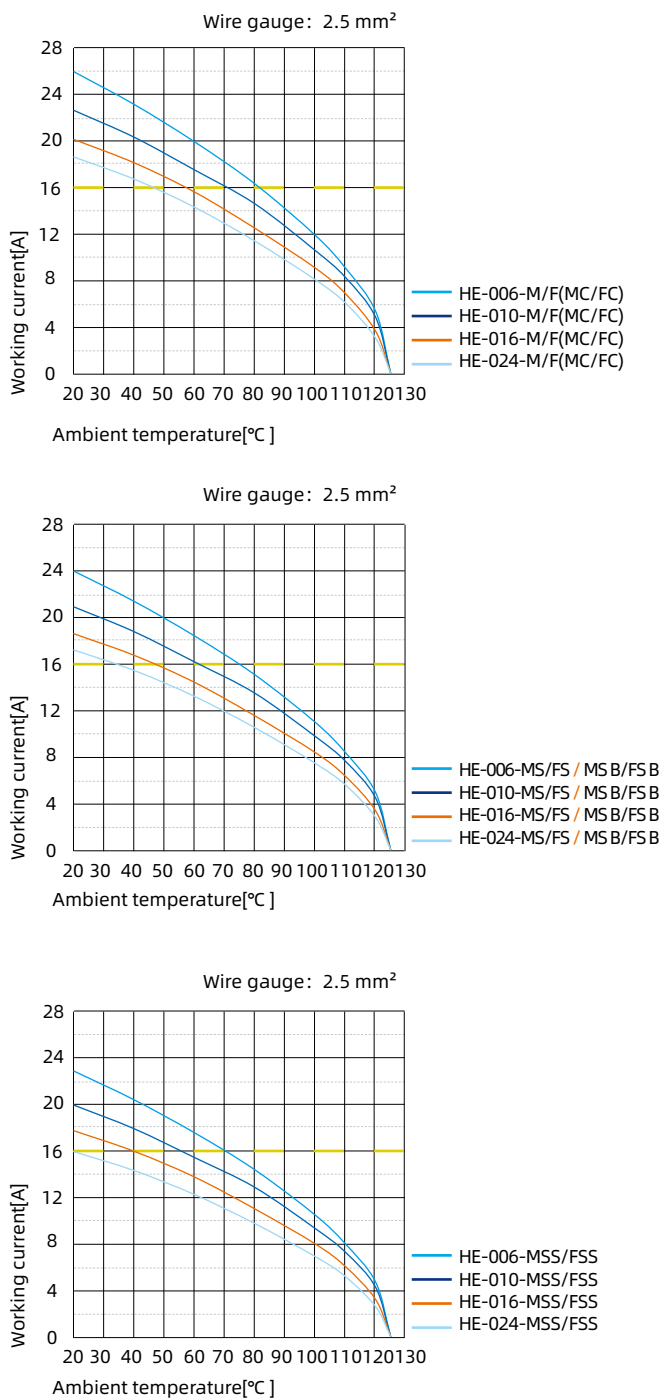

HE-006 Standard inserts

500V 16A 6+ 

Inserts

Hoods/Housings: size 6B, please find the details on page 15-25~15-38.2.

Screw terminal



Insert	Designation	Order No.
Male	HE-006-M	122 006 011 0001
Female	HE-006-F	122 006 021 0001

Crimp terminal

Order crimp contacts separately



Insert	Designation	Order No.
Male	HE-006-MC ¹⁾	122 006 010 0001
Female	HE-006-FC ¹⁾	122 006 020 0001

1).can match PCB adapter,see page 14-04~14-05.

Male	HE-006-MC/N ²⁾	122 006 010 0101
Female	HE-006-FC/N ²⁾	122 006 020 0101

2).for crimp contacts 16A-Enhanced III ,see page 13-04.

Spring terminal, See P00-14 for the structural characteristics of spring.



Insert	Designation	Order No.
Male	HE-006-MS	122 006 012 0001
Female	HE-006-FS	122 006 022 0001

Male	HE-006-MS B	122 006 012 0101
Female	HE-006-FS B	122 006 022 0101

Double spring connection(Two terminal per contact)
Only suitable for high structure shells

Male	HE-006-MSS	122 006 012 0201
Female	HE-006-FSS	122 006 022 0201

Crimp contacts

Crimp contacts 16A

Contact resistance $\leq 1\text{m}\Omega$
silver plated

gold plated



More crimp contacts 16A see P13-04.

Tools

Crimping tool



Contact removal tool



Male	Order No.	Female	Order No.
CESM-0.37	101 019 110 0301	CESF-0.37	101 019 120 0301
CESM-0.50	101 019 110 0401	CESF-0.50	101 019 120 0401
CESM-0.75	101 019 110 0601	CESF-0.75	101 019 120 0601
CESM-1.0	101 019 110 0801	CESF-1.0	101 019 120 0801
CESM-1.5	101 019 110 0901	CESF-1.5	101 019 120 0901
CESM-2.5	101 019 110 1001	CESF-2.5	101 019 120 1001
CESM-3.0	101 019 110 1101	CESF-3.0	101 019 120 1101
CESM-4.0	101 019 110 1201	CESF-4.0	101 019 120 1201

CEGM-0.37	101 019 210 0301	CEGF-0.37	101 019 220 0301
CEGM-0.50	101 019 210 0401	CEGF-0.50	101 019 220 0401
CEGM-0.75	101 019 210 0601	CEGF-0.75	101 019 220 0601
CEGM-1.0	101 019 210 0801	CEGF-1.0	101 019 220 0801
CEGM-1.5	101 019 210 0901	CEGF-1.5	101 019 220 0901
CEGM-2.5	101 019 210 1001	CEGF-2.5	101 019 220 1001
CEGM-3.0	101 019 210 1101	CEGF-3.0	101 019 220 1101
CEGM-4.0	101 019 210 1201	CEGF-4.0	101 019 220 1201

Wire gauge	Designation	Order No.
0.14-4mm ²	TL02G	198 001 001 0011

Wire gauge: 0.14-0.37mm² please select TL02 Crimping tool.

Application	Designation	Order No.
for crimp contacts 16A	TL01	198 001 000 0002

More tools detail please find the page 32-03~32-06.

1) Distance for contact max. 21 mm

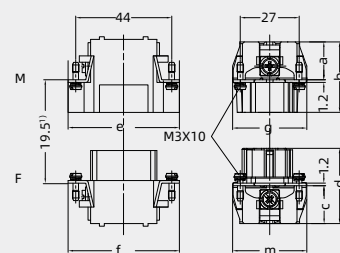

	a	b	e	g	c	d	f	m
M/F	16	32.4	51	34	16.8	34.5	50.5	34
MC/FC	18	33	51	34	18	35	50.5	34
MC/N / FC/N	18.3	34	51	34	19	36	51	34
MS/FS	18	33.3	51	34	18.2	35.4	50.5	34
MSS/FSS	34.5	49.5	50	34	33.4	50	50	34
MS B / FS B	19.5	34.7	51	34	19	36.5	51	34

Contact arrangement view from termination side

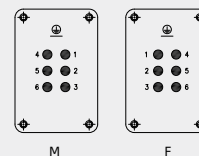

Panel cut out for inserts for use without hoods/housings

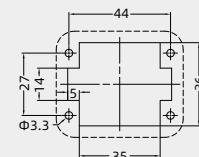

Notes: The tools for crimp terminal may influence the product quality and stability. Please select the tools recognized by our company.

HE-006 Quick-in module

500V 16A 6+ 



Inserts



Hoods/Housings: size 6B, please find the details on page 15-25-15-38.2.

Spring terminal(Quick-in)

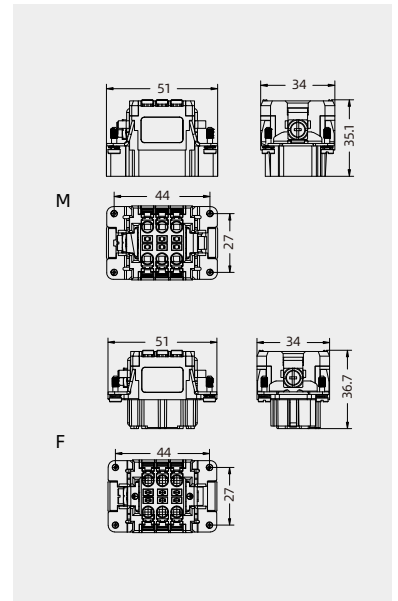
Insert	Designation	Order No.
Male	HE-006-MQ P	122 000 099 0500
Female	HE-006-FQ P	122 000 099 0501



Bridging module

Description	Designation	Order No.
	HEB/P-2T1	198 002 007 0029
	HEB/P-1T3	198 002 007 0028
	HEB/P-1T2	198 002 007 0027

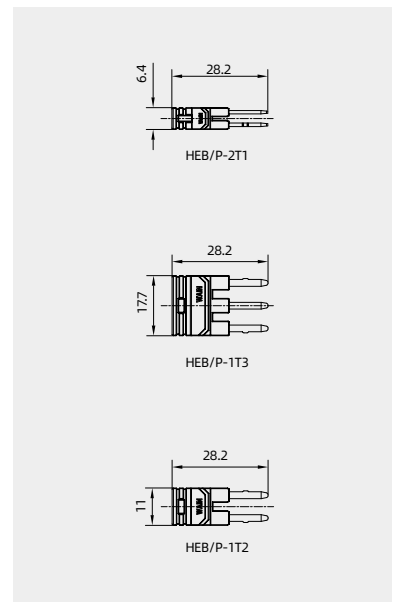

HE-010 Standard inserts

500V 16A 10+ 

Inserts



Hoods/Housings: size 10B, please find the details on page 15-39~15-69.

Screw terminal



Insert	Designation	Order No.
Male	HE-010-M	122 010 011 0001
Female	HE-010-F	122 010 021 0001

Crimp terminal

Order crimp contacts separately



Insert	Designation	Order No.
Male	HE-010-MC ¹⁾	122 010 010 0001
Female	HE-010-FC ¹⁾	122 010 020 0001

¹⁾can match PCB adapter,see page 14-04~14-05.

Spring terminal, See P00-14 for the structural characteristics of spring.



Insert	Designation	Order No.
Male	HE-010-MS	122 010 012 0001
Female	HE-010-FS	122 010 022 0001

Male	HE-010-MS B	122 010 012 0101
Female	HE-010-FS B	122 010 022 0101

Double spring connection(Two terminal per contact)
Only suitable for high structure shells

Male	HE-010-MSS	122 010 012 0201
Female	HE-010-FSS	122 010 022 0201

1) Distance for contact max. 21 mm

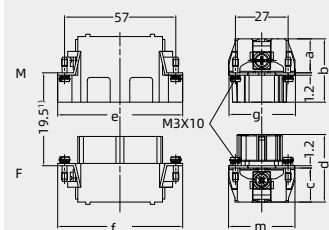

	a	b	e	g	c	d	f	m
M/F	16.5	32	64.5	34	16.8	34.2	64	34
MC/FC	18	33	64	34	17.5	35.2	64	34
MS/Fs	18.5	33.5	64	34	18.5	35.6	64	34
MSS/FSS	34	49	64	34	33.5	49.5	63	34
MS B / FS B	19	34.5	64	34	18.6	36	64	34

Contact arrangement view from termination side

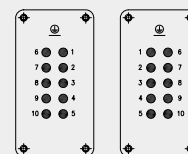

Panel cut out for inserts for use without hoods/housings

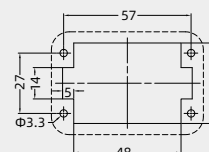

Crimp contacts

Crimp contacts 16A

Contact resistance ≤ 1mΩ
silver plated

gold plated



More crimp contacts 16A see P13-04.

Tools

Crimping tool



Contact removal tool



Male	Order No.	Female	Order No.
CESM-0.37	101 019 110 0301	CESF-0.37	101 019 120 0301
CESM-0.50	101 019 110 0401	CESF-0.50	101 019 120 0401
CESM-0.75	101 019 110 0601	CESF-0.75	101 019 120 0601
CESM-1.0	101 019 110 0801	CESF-1.0	101 019 120 0801
CESM-1.5	101 019 110 0901	CESF-1.5	101 019 120 0901
CESM-2.5	101 019 110 1001	CESF-2.5	101 019 120 1001
CESM-3.0	101 019 110 1101	CESF-3.0	101 019 120 1101
CESM-4.0	101 019 110 1201	CESF-4.0	101 019 120 1201

CEGM-0.37	101 019 210 0301	CEGF-0.37	101 019 220 0301
CEGM-0.50	101 019 210 0401	CEGF-0.50	101 019 220 0401
CEGM-0.75	101 019 210 0601	CEGF-0.75	101 019 220 0601
CEGM-1.0	101 019 210 0801	CEGF-1.0	101 019 220 0801
CEGM-1.5	101 019 210 0901	CEGF-1.5	101 019 220 0901
CEGM-2.5	101 019 210 1001	CEGF-2.5	101 019 220 1001
CEGM-3.0	101 019 210 1101	CEGF-3.0	101 019 220 1101
CEGM-4.0	101 019 210 1201	CEGF-4.0	101 019 220 1201

Wire gauge	Designation	Order No.
0.14-4mm ²	TL02G	198 001 001 0011

Wire gauge: 0.14-0.37mm² please select TL02 Crimping tool.

Application	Designation	Order No.
for crimp contacts 16A	TL01	198 001 000 0002

More tools detail please find the page 32-03~32-06.

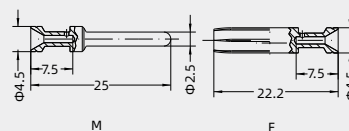

Identification	Wire gauge	Stripping length
no groove	0.14-0.37 mm ² AWG 26-22	7.5mm
no groove	0.5 mm ² AWG 20	7.5mm
1 groove	0.75 mm ² AWG 18	7.5mm
1 groove	1 mm ² AWG 18	7.5mm
2 grooves	1.5 mm ² AWG 16	7.5mm
3 grooves	2.5 mm ² AWG 14	7.5mm
wide groove	3 mm ² AWG 12	7.5mm
no groove	4 mm ² AWG 12	7.5mm

When the wire gauge is less than 0.75mm², it's better to use the auxiliary pin assembly tool TL15.

Notes: The tools for crimp terminal may influence the product quality and stability. Please select the tools recognized by our company.

HE-010 Quick-in module

500V 16A 10+ 



Inserts



Hoods/Housings: size **10B**, please find the details on page 15-39~15-69.

Spring terminal(Quick-in)

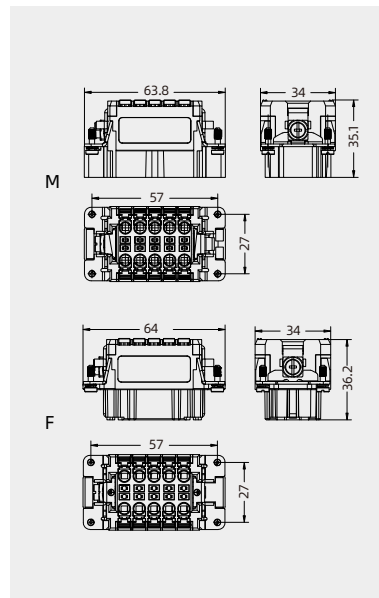
Insert	Designation	Order No.
Male	HE-010-MQ P	122 000 099 0502
Female	HE-010-FQ P	122 000 099 0503



Bridging module

Description	Designation	Order No.
	HEB/P-2T1	198 002 007 0029
	HEB/P-1T3	198 002 007 0028
	HEB/P-1T2	198 002 007 0027

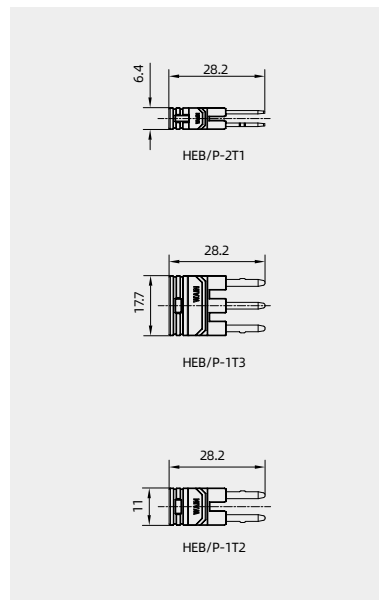

HE-016 Standard inserts

500V 16A 16+ 

Inserts



Hoods/Housings: size 16B, please find the details on page 15-70~15-1071.

Screw terminal



Insert	Designation	Order No.
Male	HE-016-M	122 016 011 0001
Female	HE-016-F	122 016 021 0001

Crimp terminal

Order crimp contacts separately



Insert	Designation	Order No.
Male	HE-016-MC ¹⁾	122 016 010 0001
Female	HE-016-FC ¹⁾	122 016 020 0001

¹⁾can match PCB adapter,see page 14-04-14-05.

Spring terminal, See P00-14 for the structural characteristics of spring.



Insert	Designation	Order No.
Male	HE-016-MS	122 016 012 0001
Female	HE-016-FS	122 016 022 0001

Male	HE-016-MS B	122 016 012 0101
Female	HE-016-FS B	122 016 022 0101

Double spring connection(Two terminal per contact)
Only suitable for high structure shells

Male	HE-016-MSS	122 016 012 0201
Female	HE-016-FSS	122 016 022 0201

1) Distance for contact max. 21 mm

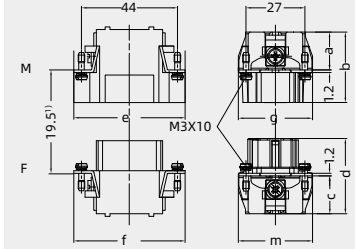

	a	b	e	g	c	d	f	m
M/F	16	32.4	51	34	16.8	34.5	50.5	34
MC/FC	18	33	51	34	18	35	50.5	34
MC/N / FC/N	18.3	34	51	34	19	36	51	34
MS/FS	18	33.3	51	34	18.2	35.4	50.5	34
MSS/FSS	34.5	49.5	50	34	33.4	50	50	34
MS B / FS B	19.5	34.7	51	34	19	36.5	51	34

Contact arrangement view from termination side

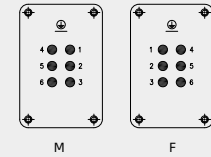

Panel cut out for inserts for use without hoods/housings

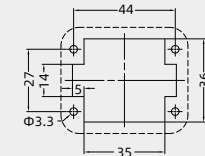

Crimp contacts

Crimp contacts 16A

Contact resistance ≤ 1mΩ
silver plated

gold plated



More crimp contacts 16A see P13-04.

Tools

Crimping tool



Contact removal tool



Male	Order No.	Female	Order No.
CESM-0.37	101 019 110 0301	CESF-0.37	101 019 120 0301
CESM-0.50	101 019 110 0401	CESF-0.50	101 019 120 0401
CESM-0.75	101 019 110 0601	CESF-0.75	101 019 120 0601
CESM-1.0	101 019 110 0801	CESF-1.0	101 019 120 0801
CESM-1.5	101 019 110 0901	CESF-1.5	101 019 120 0901
CESM-2.5	101 019 110 1001	CESF-2.5	101 019 120 1001
CESM-3.0	101 019 110 1101	CESF-3.0	101 019 120 1101
CESM-4.0	101 019 110 1201	CESF-4.0	101 019 120 1201

CEGM-0.37	101 019 210 0301	CEGF-0.37	101 019 220 0301
CEGM-0.50	101 019 210 0401	CEGF-0.50	101 019 220 0401
CEGM-0.75	101 019 210 0601	CEGF-0.75	101 019 220 0601
CEGM-1.0	101 019 210 0801	CEGF-1.0	101 019 220 0801
CEGM-1.5	101 019 210 0901	CEGF-1.5	101 019 220 0901
CEGM-2.5	101 019 210 1001	CEGF-2.5	101 019 220 1001
CEGM-3.0	101 019 210 1101	CEGF-3.0	101 019 220 1101
CEGM-4.0	101 019 210 1201	CEGF-4.0	101 019 220 1201

Wire gauge	Designation	Order No.
0.14-4mm ²	TL02G	198 001 001 0011

Wire gauge: 0.14-0.37mm² please select TL02 Crimping tool.

Application	Designation	Order No.
for crimp contacts 16A	TL01	198 001 000 0002

More tools detail please find the page 32-03-32-06.

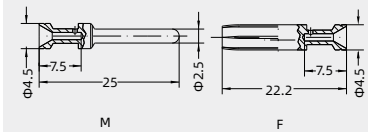

Identification	Wire gauge	Stripping length
no groove	0.14-0.37 mm ² AWG 26-22	7.5mm
no groove	0.5 mm ² AWG 20	7.5mm
1 groove	0.75 mm ² AWG 18	7.5mm
1 groove	1 mm ² AWG 18	7.5mm
2 grooves	1.5 mm ² AWG 16	7.5mm
3 grooves	2.5 mm ² AWG 14	7.5mm
wide groove	3 mm ² AWG 12	7.5mm
no groove	4 mm ² AWG 12	7.5mm

When the wire gauge is less than 0.75mm², it's better to use the auxiliary pin assembly tool TL15.

Notes: The tools for crimp terminal may influence the product quality and stability. Please select the tools recognized by our company.

HE-016 Quick-in module

500V 16A 16+ 



Inserts



Hoods/Housings: size 16B, please find the details on page 15-70~15-107.1.

Spring terminal(Quick-in)

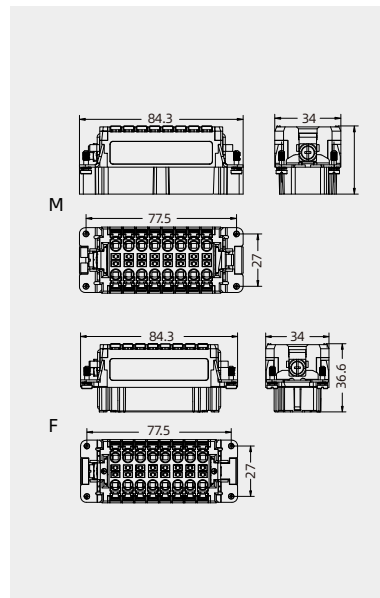
Insert	Designation	Order No.
Male	HE-016-MQ P	122 000 099 0504
Female	HE-016-FQ P	122 000 099 0505



Bridging module

Description	Designation	Order No.
	HEB/P-2T1	198 002 007 0029
	HEB/P-1T3	198 002 007 0028
	HEB/P-1T2	198 002 007 0027

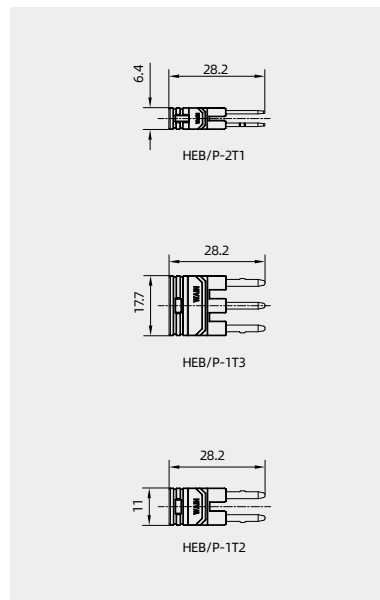

HE-024 Standard inserts

500V 16A 24+ 

Inserts



Hoods/Housings: size 24B, please find the details on page 15-108~15-150.

Screw terminal



Insert	Designation	Order No.
Male	HE-024-M	122 024 011 0001
Female	HE-024-F	122 024 021 0001

Crimp terminal

Order crimp contacts separately



Insert	Designation	Order No.
Male	HE-024-MC ¹⁾	122 024 010 0001
Female	HE-024-FC ¹⁾	122 024 020 0001

¹⁾can match PCB adapter,see page 14-04~14-05.

Spring terminal, See P00-14 for the structural characteristics of spring.



Insert	Designation	Order No.
Male	HE-024-MS	122 024 012 0001
Female	HE-024-FS	122 024 022 0001

Male	HE-024-MS B	122 024 012 0101
Female	HE-024-FS B	122 024 022 0101

Double spring connection (Two terminal per contact)
Only suitable for high structure shells

Male	HE-024-MSS	122 024 012 0201
Female	HE-024-FSS	122 024 022 0201

1) Distance for contact max. 21 mm

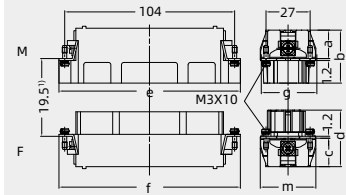

	a	b	e	g	c	d	f	m
M/F	17	32.5	111	33.5	17	34.5	111	33.5
MC/FC	18.3	33.5	111	34	18.3	35.5	111	34
MS/FS	18.5	33.6	111	34	18.5	35.6	111	34
MSS/FSS	34	49	110	34	32	49	110	34
MS B / FS B	19.6	34.7	111	34	19	36.2	111	34

Contact arrangement view from termination side

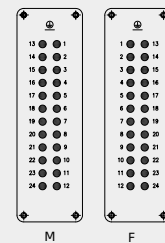

Panel cut out for inserts for use without hoods/housings

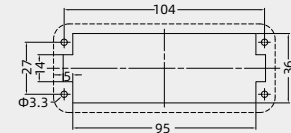

Crimp contacts

Crimp contacts 16A

Contact resistance ≤ 1mΩ
silver plated

gold plated



More crimp contacts 16A see P13-04.

Tools

Crimping tool



Contact removal tool



Male	Order No.	Female	Order No.
CESM-0.37	101 019 110 0301	CESF-0.37	101 019 120 0301
CESM-0.50	101 019 110 0401	CESF-0.50	101 019 120 0401
CESM-0.75	101 019 110 0601	CESF-0.75	101 019 120 0601
CESM-1.0	101 019 110 0801	CESF-1.0	101 019 120 0801
CESM-1.5	101 019 110 0901	CESF-1.5	101 019 120 0901
CESM-2.5	101 019 110 1001	CESF-2.5	101 019 120 1001
CESM-3.0	101 019 110 1101	CESF-3.0	101 019 120 1101
CESM-4.0	101 019 110 1201	CESF-4.0	101 019 120 1201

CEGM-0.37	101 019 210 0301	CEGF-0.37	101 019 220 0301
CEGM-0.50	101 019 210 0401	CEGF-0.50	101 019 220 0401
CEGM-0.75	101 019 210 0601	CEGF-0.75	101 019 220 0601
CEGM-1.0	101 019 210 0801	CEGF-1.0	101 019 220 0801
CEGM-1.5	101 019 210 0901	CEGF-1.5	101 019 220 0901
CEGM-2.5	101 019 210 1001	CEGF-2.5	101 019 220 1001
CEGM-3.0	101 019 210 1101	CEGF-3.0	101 019 220 1101
CEGM-4.0	101 019 210 1201	CEGF-4.0	101 019 220 1201

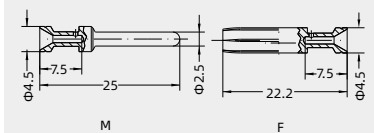

Identification	Wire gauge	Stripping length
no groove	0.14-0.37 mm ² AWG 26-22	7.5mm
no groove	0.5 mm ² AWG 20	7.5mm
1 groove	0.75 mm ² AWG 18	7.5mm
1 groove	1 mm ² AWG 18	7.5mm
2 grooves	1.5 mm ² AWG 16	7.5mm
3 grooves	2.5 mm ² AWG 14	7.5mm
wide groove	3 mm ² AWG 12	7.5mm
no groove	4 mm ² AWG 12	7.5mm

When the wire gauge is less than 0.75mm², it's better to use the auxiliary pin assembly tool TL15.

Wire gauge	Designation	Order No.
0.14-4mm ²	TL02G	198 001 001 0011

Wire gauge: 0.14-0.37mm² please select TL02 Crimping tool.

Application	Designation	Order No.
for crimp contacts 16A	TL01	198 001 000 0002

More tools detail please find the page 32-03~32-06.

Notes: The tools for crimp terminal may influence the product quality and stability. Please select the tools recognized by our company.

HE-024 Quick-in module

500V 16A 24+ 

Inserts

Hoods/Housings: size 24B, please find the details on page 15-108~15-150.

Spring terminal(Quick-in) 



Insert	Designation	Order No.
Male	HE-024-MQ P	122 024 010 0003
Female	HE-024-FQ P	122 024 020 0003

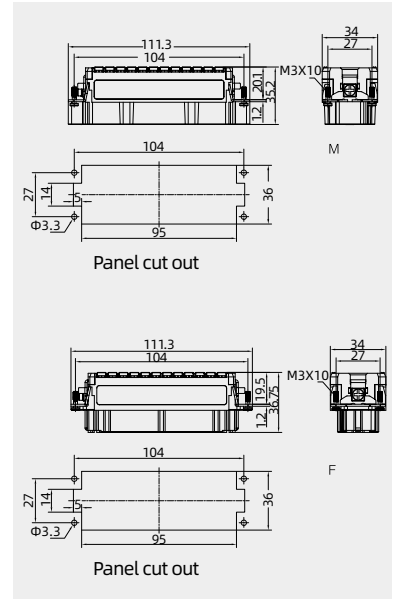

Bridging module 



Description	Designation	Order No.
	HEB/P-2T1	198 002 007 0029
	HEB/P-1T3	198 002 007 0028
	HEB/P-1T2	198 002 007 0027

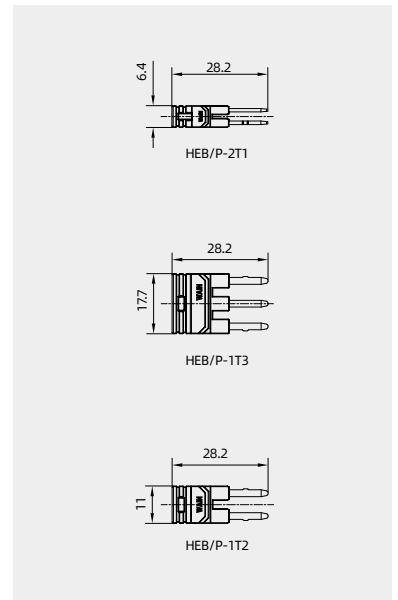

HE-032 Standard inserts

500V 16A 32+ 

VDE CE ENE CCC

Inserts



Hoods/Housings: size 32B, please find the details on page 15-151~15-159.

Screw terminal



Insert	Designation	Order No.
Male	HE-016-M	122 016 011 0001
	HE-016-M(17-32)	122 016 011 0002
Female	HE-016-F	122 016 021 0001
	HE-016-F(17-32)	122 016 021 0002

Crimp terminal

Order crimp contacts separately



Insert	Designation	Order No.
Male	HE-016-MC	122 016 010 0001
	HE-016-MS(17-32) ¹⁾	122 016 010 0002
Female	HE-016-FC	122 016 020 0001
	HE-016-FS(17-32) ¹⁾	122 016 020 0002

¹⁾can match PCB adapter,see page 14-04-14-05.

Spring terminal, See P00-14 for the structural characteristics of spring.



Insert	Designation	Order No.
Male	HE-016-MS	122 016 012 0001
	HE-016-MS(17-32)	122 016 012 0002
Female	HE-016-FS	122 016 022 0001
	HE-016-FS(17-32)	122 016 022 0002
Male	HE-016-MS B	122 016 012 0101
	HE-016-MS B(17-32)	122 016 012 0102
Female	HE-016-FS B	122 016 022 0101
	HE-016-FS B(17-32)	122 016 022 0102
Double spring connection(Two terminal per contact) Only suitable for high structure shells		
Male	HE-016-MSS	122 016 012 0201
	HE-016-MSS(17-32)	122 016 012 0202
Female	HE-016-FSS	122 016 022 0201
	HE-016-FSS(17-32)	122 016 022 0202

Crimp contacts

Crimp contacts 16A

Contact resistance ≤ 1mΩ
silver plated

gold plated



More crimp contacts 16A see P13-04.

Tools

Crimping tool



Contact removal tool



Male	Order No.	Female	Order No.
CESM-0.37	101 019 110 0301	CESF-0.37	101 019 120 0301
CESM-0.50	101 019 110 0401	CESF-0.50	101 019 120 0401
CESM-0.75	101 019 110 0601	CESF-0.75	101 019 120 0601
CESM-1.0	101 019 110 0801	CESF-1.0	101 019 120 0801
CESM-1.5	101 019 110 0901	CESF-1.5	101 019 120 0901
CESM-2.5	101 019 110 1001	CESF-2.5	101 019 120 1001
CESM-3.0	101 019 110 1101	CESF-3.0	101 019 120 1101
CESM-4.0	101 019 110 1201	CESF-4.0	101 019 120 1201
CEGM-0.37	101 019 210 0301	CEGF-0.37	101 019 220 0301
CEGM-0.50	101 019 210 0401	CEGF-0.50	101 019 220 0401
CEGM-0.75	101 019 210 0601	CEGF-0.75	101 019 220 0601
CEGM-1.0	101 019 210 0801	CEGF-1.0	101 019 220 0801
CEGM-1.5	101 019 210 0901	CEGF-1.5	101 019 220 0901
CEGM-2.5	101 019 210 1001	CEGF-2.5	101 019 220 1001
CEGM-3.0	101 019 210 1101	CEGF-3.0	101 019 220 1101
CEGM-4.0	101 019 210 1201	CEGF-4.0	101 019 220 1201

Wire gauge	Designation	Order No.
0.14-4mm ²	TL02G	198 001 001 0011
Wire gauge: 0.14-0.37mm ² please select TL02 Crimping tool.		
Application	Designation	Order No.
for crimp contacts 16A	TL01	198 001 000 0002

More tools detail please find the page 32-03-32-06.

1) Distance for contact max. 21 mm

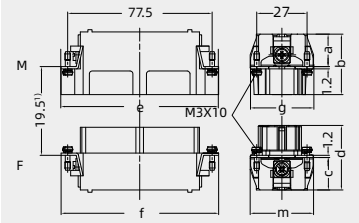

	a	b	e	g	c	d	f	m
M/F	17	32.5	84.2	34	17	34.5	84.2	33.5
MC/FC	18	33.5	84.5	34	18	35	84.5	34
MS/FS	18	33.7	84.5	34	18.2	35.5	84.5	34
MSS/FSS	34.3	49	84.5	34	32.2	49	84.5	34
MSB / FS B	19.6	34.7	84.3	34	18.6	36	84.5	34

Contact arrangement view from termination side

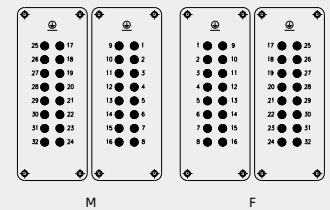

Panel cut out for inserts for use without hoods/housings

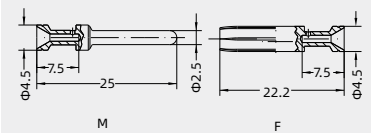
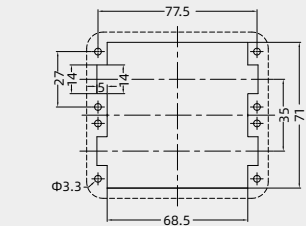

Identification	Wire gauge	Stripping length	
no groove	0.14-0.37 mm ²	AWG 26-22	7.5mm
no groove	0.5 mm ²	AWG 20	7.5mm
1 groove	0.75 mm ²	AWG 18	7.5mm
1 groove	1 mm ²	AWG 18	7.5mm
2 grooves	1.5 mm ²	AWG 16	7.5mm
3 grooves	2.5 mm ²	AWG 14	7.5mm
wide groove	3 mm ²	AWG 12	7.5mm
no groove	4 mm ²	AWG 12	7.5mm

When the wire gauge is less than 0.75mm², it's better to use the auxiliary pin assembly tool TL15.

Notes: The tools for crimp terminal may influence the product quality and stability. Please select the tools recognized by our company.

HE-048 Standard inserts

500V 16A 48+



Inserts



Hoods/Housings: size 48B, please find the details on page 15-160~15-162.

Screw terminal



Insert	Designation	Order No.
Male	HE-024-M	122 024 011 0001
	HE-024-M(25-48)	122 024 011 0002
Female	HE-024-F	122 024 021 0001
	HE-024-F(25-48)	122 024 021 0002

Crimp terminal

Order crimp contacts separately



Insert	Designation	Order No.
Male	HE-024-MC	122 024 010 0001
	HE-024-MC(25-48) ¹⁾	122 024 010 0002
Female	HE-024-FC	122 024 020 0001
	HE-024-FC(25-48) ¹⁾	122 024 020 0002

¹⁾can match PCB adapter,see page 14-04-14-05.

Spring terminal, See P00-14 for the structural characteristics of spring.



Insert	Designation	Order No.
Male	HE-024-MS	122 024 012 0001
	HE-024-MS(25-48)	122 024 012 0002
Female	HE-024-FS	122 024 022 0001
	HE-024-FS(25-48)	122 024 022 0002
Male	HE-024-MS B	122 024 012 0101
	HE-024-MS B(25-48)	122 024 012 0102
Female	HE-024-FS B	122 024 022 0101
	HE-024-FS B(25-48)	122 024 022 0102
Double spring connection(Two terminal per contact) Only suitable for high structure shells		
Male	HE-024-MSS	122 024 012 0201
	HE-024-MSS(25-48)	122 024 012 0202
Female	HE-024-FSS	122 024 022 0201
	HE-024-FSS(25-48)	122 024 022 0202

1) Distance for contact max. 21 mm

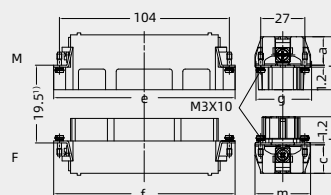

M/F	a	b	e	g	c	d	f	m
MC/FC	18.3	33.5	111	34	18.3	35.5	111	34
MS/FS	18.5	33.6	111	34	18.5	35.6	111	34
MSS/FSS	34	49	110	34	32	49	110	34
MS B / FS B	19.6	34.7	111	34	19	36.2	111	34

Contact arrangement view from termination side

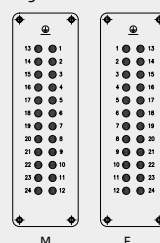

Panel cut out for inserts for use without hoods/housings

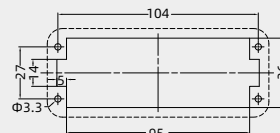

Crimp contacts

Crimp contacts 16A

Contact resistance ≤ 1mΩ silver plated



gold plated



More crimp contacts 16A see P13-04.

Tools

Crimping tool



Contact removal tool



Male	Order No.	Female	Order No.
CESM-0.37	101 019 110 0301	CESF-0.37	101 019 120 0301
CESM-0.50	101 019 110 0401	CESF-0.50	101 019 120 0401
CESM-0.75	101 019 110 0601	CESF-0.75	101 019 120 0601
CESM-1.0	101 019 110 0801	CESF-1.0	101 019 120 0801
CESM-1.5	101 019 110 0901	CESF-1.5	101 019 120 0901
CESM-2.5	101 019 110 1001	CESF-2.5	101 019 120 1001
CESM-3.0	101 019 110 1101	CESF-3.0	101 019 120 1101
CESM-4.0	101 019 110 1201	CESF-4.0	101 019 120 1201
CEGM-0.37	101 019 210 0301	CEGF-0.37	101 019 220 0301
CEGM-0.50	101 019 210 0401	CEGF-0.50	101 019 220 0401
CEGM-0.75	101 019 210 0601	CEGF-0.75	101 019 220 0601
CEGM-1.0	101 019 210 0801	CEGF-1.0	101 019 220 0801
CEGM-1.5	101 019 210 0901	CEGF-1.5	101 019 220 0901
CEGM-2.5	101 019 210 1001	CEGF-2.5	101 019 220 1001
CEGM-3.0	101 019 210 1101	CEGF-3.0	101 019 220 1101
CEGM-4.0	101 019 210 1201	CEGF-4.0	101 019 220 1201

Wire gauge	Designation	Order No.
0.14-4mm ²	TL02G	198 001 001 0011
Wire gauge: 0.14-0.37mm ² please select TL02 Crimping tool.		
Application	Designation	Order No.
for crimp contacts 16A	TL01	198 001 000 0002

More tools detail please find the page 32-03-32-06.

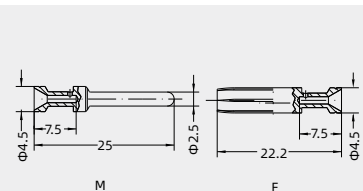

Identification	Wire gauge	Stripping length
no groove	0.14-0.37 mm ² AWG 26-22	7.5mm
no groove	0.5 mm ² AWG 20	7.5mm
1 groove	0.75 mm ² AWG 18	7.5mm
1 groove	1 mm ² AWG 18	7.5mm
2 grooves	1.5 mm ² AWG 16	7.5mm
3 grooves	2.5 mm ² AWG 14	7.5mm
wide groove	3 mm ² AWG 12	7.5mm
no groove	4 mm ² AWG 12	7.5mm

When the wire gauge is less than 0.75mm², it's better to use the auxiliary pin assembly tool TL15.

Notes: The tools for crimp terminal may influence the product quality and stability. Please select the tools recognized by our company.

HE push spring insert

Tools

HE B Spring open machine¹⁾

Description	Designation	Order NO.
for all HE B spring inserts	SOM01	198 001 003 0008

1) It can open all the shrapnel windows of insert at one time; suitable for using in mass assembly, greatly improving the efficiency of the connection.

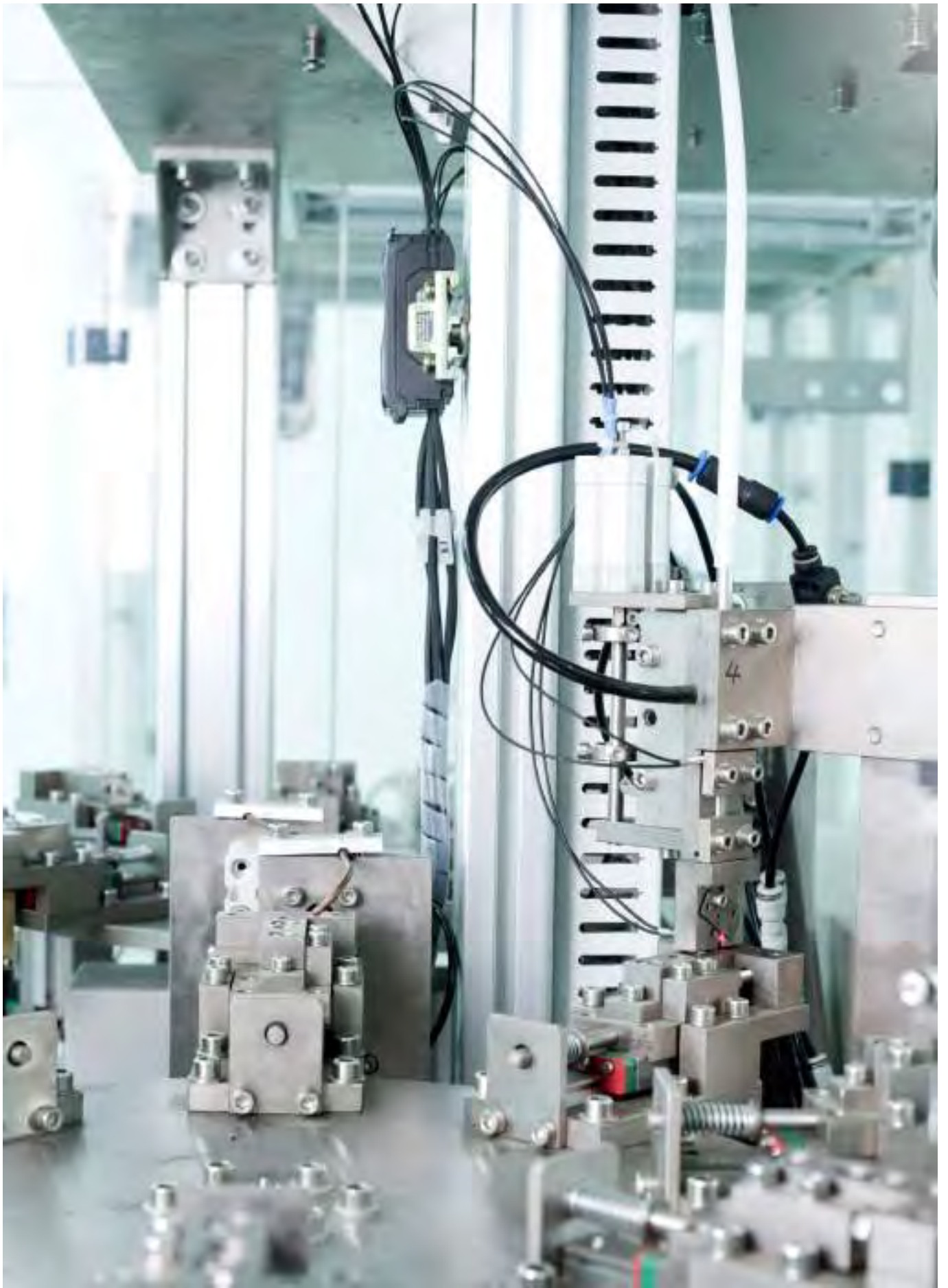

HVE SERIES

High voltage connector

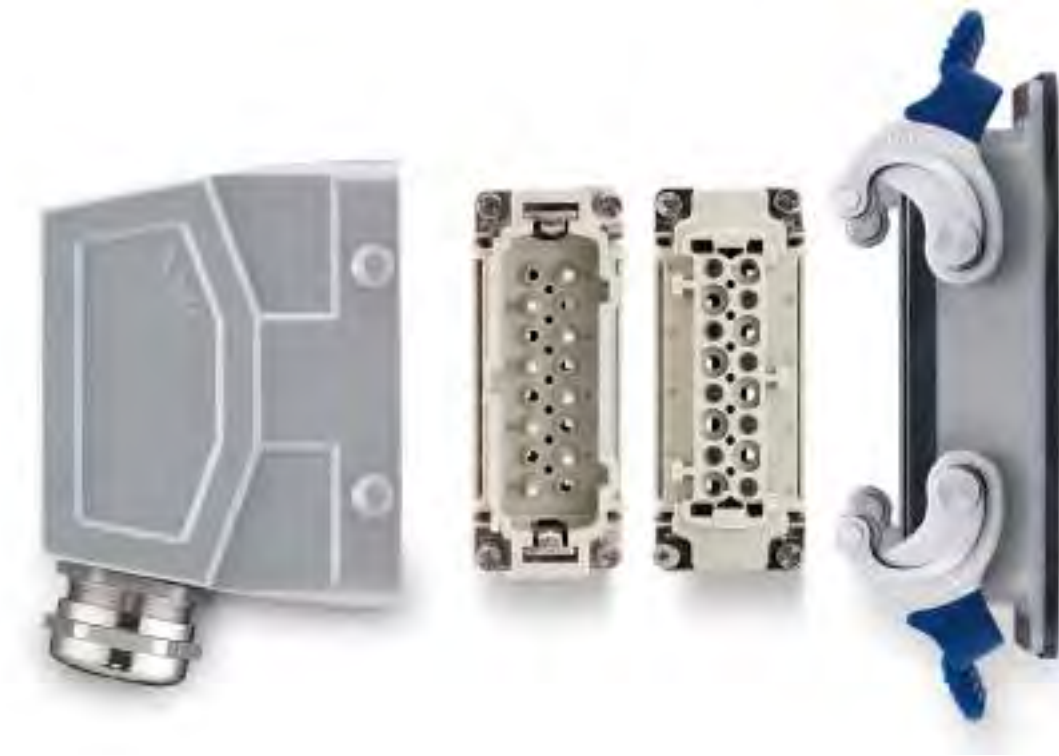

HVE SERIES High voltage inserts

Technical characteristics

Specifications	DIN EN 60 664 DIN EN 61 984
Approvals	
Inserts	
Number of contacts	3,6,10,12,20+PE
Electrical data acc. to DIN EN 61 984	
-Rated current	16A
-Rated voltage	830V
-Rated impulse voltage	8kV
-Pollution degree	3
-Pollution degree 2 also	16A 1000V 8kV 2
-or	16A 720/1250V 8kV 2
-Relay contacts	16A 500V 6kV 3
Rated voltage acc. to UL	600V
Relay contacts	250V
Insulation resistance	$\geq 10^{10}\Omega$
Material	polycarbonate
Limiting temperatures	-40°C ...+125°C
Flammability acc. to UL 94	V0
Mechanical working life(mating cycles)	≥ 500
Contacts	
Material	copper alloy
Surface	hard-silver plated
Contact resistance	$\leq 1m\Omega$
Screw terminal	
-Wire gauge	1.0-2.5mm ²
-AWG	18-14
-Tightening/test torque	0.5Nm
-Stripping length	7.0mm
Crimp terminal	
-Wire gauge	0.14-4.0mm ²
-AWG	26-12
-Stripping length	7.5mm

For a fully equipped crimp connector the following contacts are required:

Type	Contacts total	Operating contacts	Relay contacts
HVE-003	5	3	2
HVE-006	8	6	2
HVE-010	12	10	2
HVE-012	16	12	4
HVE-020	24	20	4

Current carrying capacity

The current carrying is limited by maximum temperature of materials for inserts and contacts including terminals

Control and test procedures according to DIN EN 60512-5

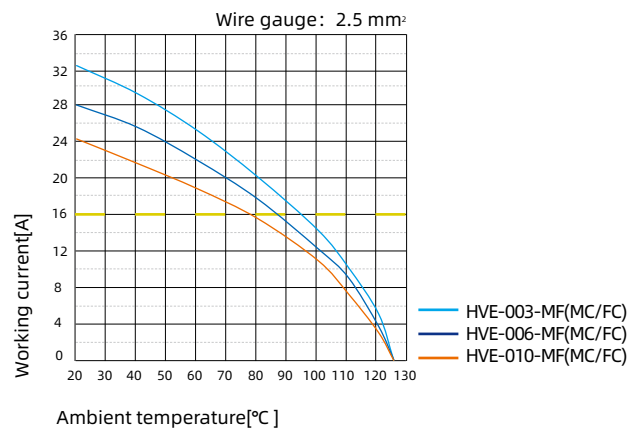
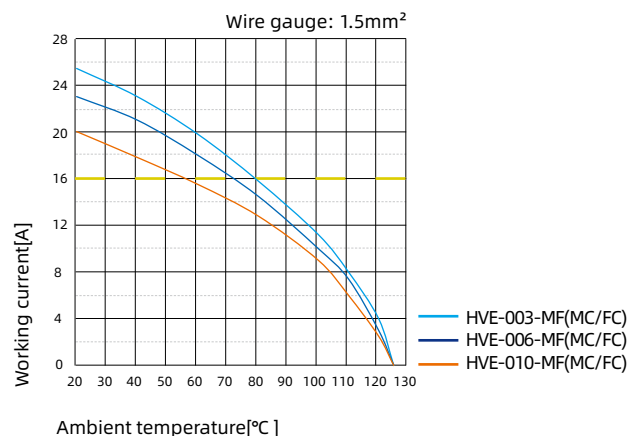

HVE-003 High voltage inserts

830V 16A 3+2+



Inserts

Hoods/Housings: Screw terminal size **10B Plastic** or **WV10B/HV10B**, please find the details on page 15-39, 15-60~15-69.
Crimp terminal size **10B**, please find the details on page 15-39~15-69.

Screw terminal



Insert	Designation	Order No.
Male	HVE-003-M	124 003 011 0001
Female	HVE-003-F	124 003 021 0001

Crimp terminal

Order crimp contacts separately



Insert	Designation	Order No.
Male	HVE-003-MC	124 003 010 0001
Female	HVE-003-FC	124 003 020 0001

1) Distance for contact max. 21 mm

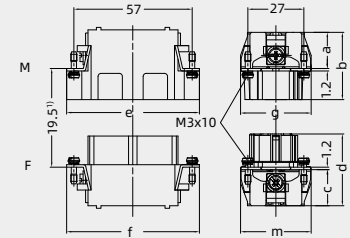

	a	b	e	g	c	d	f	m
M/F	16.5	32	64.5	34	16.8	34.2	64	34
MC/FC	18	33	64	34	17.5	35.2	64	34

Contact arrangement view from termination side

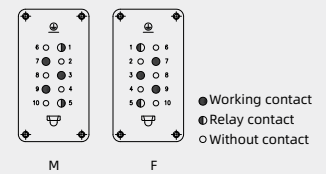

Panel cut out for inserts for use without hoods/housings

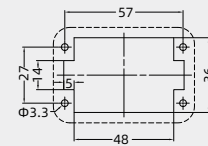

Crimp contacts

Crimp contacts 16A

16A Operating contacts
Contact resistance ≤ 1mΩ
silver plated



Relay contacts²⁾
silver plated



More crimp contacts 16A see P13-04.

Tools

Crimping tool



Contact removal tool



Male	Order No.	Female	Order No.
CESM-0.37	101 019 110 0301	CESF-0.37	101 019 120 0301
CESM-0.50	101 019 110 0401	CESF-0.50	101 019 120 0401
CESM-0.75	101 019 110 0601	CESF-0.75	101 019 120 0601
CESM-1.0	101 019 110 0801	CESF-1.0	101 019 120 0801
CESM-1.5	101 019 110 0901	CESF-1.5	101 019 120 0901
CESM-2.5	101 019 110 1001	CESF-2.5	101 019 120 1001
CESM-3.0	101 019 110 1101	CESF-3.0	101 019 120 1101
CESM-4.0	101 019 110 1201	CESF-4.0	101 019 120 1201

Wire gauge	Designation	Order No.
1	CESM-1.0R	101 019 110 0808
1.5	CESM-1.5R	101 019 110 0908
2.5	CESM-2.5R	101 019 110 1008

Wire gauge	Designation	Order No.
0.14-4mm ²	TL02G	198 001 001 0011

Application	Designation	Order No.
for crimp contacts 16A	TL01	198 001 000 0002

More tools detail please find the page 32-03~32-06.

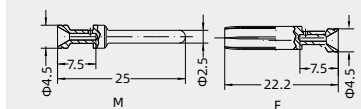

Identification	Wire gauge	Stripping length	
no groove	0.14-0.37 mm ²	AWG 26-22	7.5mm
no groove	0.5 mm ²	AWG 20	7.5mm
1 groove	0.75 mm ²	AWG 18	7.5mm
1 groove	1 mm ²	AWG 18	7.5mm
2 grooves	1.5 mm ²	AWG 16	7.5mm
3 grooves	2.5 mm ²	AWG 14	7.5mm
wide groove	3 mm ²	AWG 12	7.5mm
no groove	4 mm ²	AWG 12	7.5mm

When the wire gauge is less than 0.75mm², it's better to use the auxiliary pin assembly tool TL15.

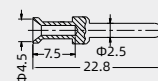

Notes: The tools for crimp terminal may influence the product quality and stability. Please select the tools recognized by our company.
2) Delay pin is relatively short, delay contact, protect circuit to avoid electric arc.

HVE-006 Standard inserts

830V 16A 6+2+⊕



Hoods/Housings: Screw terminal size 16B Plastic or WV16B/HV16B, please find the details on page 15-70, 15-68~96-107.1
Crimp terminal size 16B, please find the details on page 15-70~15-107.

Inserts



Screw terminal



Insert	Designation	Order No.
Male	HVE-006-M	124 006 011 0001
Female	HVE-006-F	124 006 021 0001

Crimp terminal

Order crimp contacts separately



Insert	Designation	Order No.
Male	HVE-006-MC	124 006 010 0001
Female	HVE-006-FC	124 006 020 0001

1) Distance for contact max. 21 mm

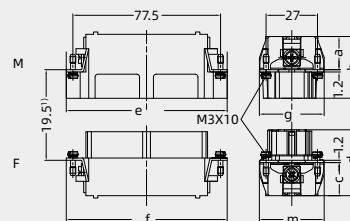

	a	b	e	g	c	d	f	m
M/F	18	32.5	84.5	34	18	34.5	84.5	34
MC/FC	18	33.5	84.5	34	18	35	84.5	34

Contact arrangement view from termination side

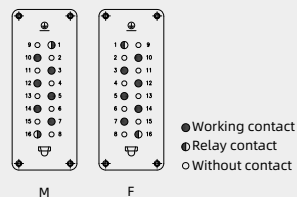

Panel cut out for inserts for use without hoods/housings

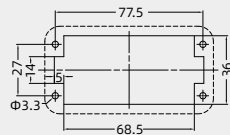

Crimp contacts

Crimp contacts 16A

16A Operating contacts
Contact resistance ≤ 1mΩ
silver plated



Male	Order No.	Female	Order No.
CESM-0.37	101 019 110 0301	CESF-0.37	101 019 120 0301
CESM-0.50	101 019 110 0401	CESF-0.50	101 019 120 0401
CESM-0.75	101 019 110 0601	CESF-0.75	101 019 120 0601
CESM-1.0	101 019 110 0801	CESF-1.0	101 019 120 0801
CESM-1.5	101 019 110 0901	CESF-1.5	101 019 120 0901
CESM-2.5	101 019 110 1001	CESF-2.5	101 019 120 1001
CESM-3.0	101 019 110 1101	CESF-3.0	101 019 120 1101
CESM-4.0	101 019 110 1201	CESF-4.0	101 019 120 1201

Relay contacts²⁾
silver plated



Wire gauge	Designation	Order No.
1	CESM-1.0R	101 019 110 0808
1.5	CESM-1.5R	101 019 110 0908
2.5	CESM-2.5R	101 019 110 1008

More crimp contacts 16A see P13-04.

Tools

Crimping tool



Wire gauge	Designation	Order No.
0.14-4mm ²	TL02G	198 001 001 0011

Wire gauge: 0.14-0.37mm² please select TL02 Crimping tool.

Contact removal tool



Application	Designation	Order No.
for crimp contacts 16A	TL01	198 001 000 0002

More tools detail please find the page 32-03~32-06.

Notes: The tools for crimp terminal may influence the product quality and stability. Please select the tools recognized by our company.
2) Delay pin is relatively short, delay contact, protect circuit to avoid electric arc.

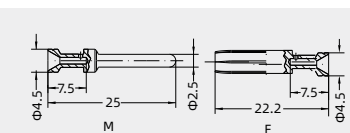

Identification	Wire gauge	Stripping length	
no groove	0.14-0.37 mm ²	AWG 26-22	7.5mm
no groove	0.5 mm ²	AWG 20	7.5mm
1 groove	0.75 mm ²	AWG 18	7.5mm
1 groove	1 mm ²	AWG 18	7.5mm
2 grooves	1.5 mm ²	AWG 16	7.5mm
3 grooves	2.5 mm ²	AWG 14	7.5mm
wide groove	3 mm ²	AWG 12	7.5mm
no groove	4 mm ²	AWG 12	7.5mm

When the wire gauge is less than 0.75mm², it's better to use the auxiliary pin assembly tool TL15.

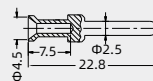

HVE-010 High voltage inserts

830V 16A 10+2+



Hoods/Housings: Screw terminal size **24B Plastic** or **WV24B/HV24B**, please find the details on page 15-108, 15-136~15-150.
Crimp terminal size **24B**, please find the details on page 15-108~15-150.

Inserts

Screw terminal



Insert	Designation	Order No.
Male	HVE-010-M	124 010 011 0001
Female	HVE-010-F	124 010 021 0001

Crimp terminal

Order crimp contacts separately



Insert	Designation	Order No.
Male	HVE-010-MC	124 010 010 0001
Female	HVE-010-FC	124 010 020 0001

1) Distance for contact max. 21 mm

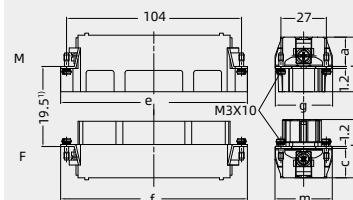

	a	b	e	g	c	d	f	m
M/F	17	32.5	111	33.5	17	34.5	111	33.5
MC/FC	18.3	33.5	111	34	18.3	35.5	111	34

Contact arrangement view from termination side

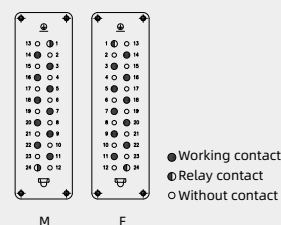

Panel cut out for inserts for use without hoods/housings

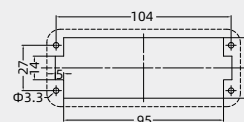

Crimp contacts

Crimp contacts 16A

16A Operating contacts
Contact resistance $\leq 1m\Omega$
silver plated



Relay contacts²⁾
silver plated



More crimp contacts 16A see P13-04.

Tools

Crimping tool



Contact removal tool



Male	Order No.	Female	Order No.
CESM-0.37	101 019 110 0301	CESF-0.37	101 019 120 0301
CESM-0.50	101 019 110 0401	CESF-0.50	101 019 120 0401
CESM-0.75	101 019 110 0601	CESF-0.75	101 019 120 0601
CESM-1.0	101 019 110 0801	CESF-1.0	101 019 120 0801
CESM-1.5	101 019 110 0901	CESF-1.5	101 019 120 0901
CESM-2.5	101 019 110 1001	CESF-2.5	101 019 120 1001
CESM-3.0	101 019 110 1101	CESF-3.0	101 019 120 1101
CESM-4.0	101 019 110 1201	CESF-4.0	101 019 120 1201

Wire gauge	Designation	Order No.
1	CESM-1.0R	101 019 110 0808
1.5	CESM-1.5R	101 019 110 0908
2.5	CESM-2.5R	101 019 110 1008

Wire gauge	Designation	Order No.
0.14-4mm ²	TL02G	198 001 001 0011

Wire gauge: 0.14-0.37mm² please select TL02 Crimping tool.

Application	Designation	Order No.
for crimp contacts 16A	TL01	198 001 000 0002

More tools detail please find the page 32-03~32-06.

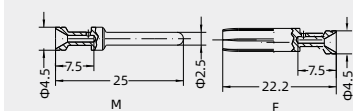

Identification	Wire gauge	Stripping length
no groove	0.14-0.37 mm ² AWG 26-22	7.5mm
no groove	0.5 mm ² AWG 20	7.5mm
1 groove	0.75 mm ² AWG 18	7.5mm
1 groove	1 mm ² AWG 18	7.5mm
2 grooves	1.5 mm ² AWG 16	7.5mm
3 grooves	2.5 mm ² AWG 14	7.5mm
wide groove	3 mm ² AWG 12	7.5mm
no groove	4 mm ² AWG 12	7.5mm

When the wire gauge is less than 0.75mm², it's better to use the auxiliary pin assembly tool TL15.

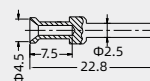

Notes: The tools for crimp terminal may influence the product quality and stability. Please select the tools recognized by our company.

2) Delay pin is relatively short, delay contact, protect circuit to avoid electric arc.

HVE-012 High voltage inserts

830V 16A 12+4+



Hoods/Housings: Screw terminal size **WV32B/HV32B**, please find the details on page 15-156~15-159.
Crimp terminal size **32B**, please find the details on page 15-151~15-159.

Inserts



Screw terminal



Insert	Designation	Order No.
Male	HVE-006-M	124 006 011 0001
	HVE-006-M(7-12)	124 006 011 0002
Female	HVE-006-F	124 006 021 0001
	HVE-006-F(7-12)	124 006 021 0002

Crimp terminal

Order crimp contacts separately



Insert	Designation	Order No.
Male	HVE-006-MC	124 006 010 0001
	HVE-006-MC(7-12)	124 006 010 0002
Female	HVE-006-FC	124 006 020 0001
	HVE-006-FC(7-12)	124 006 020 0002

1) Distance for contact max. 21 mm

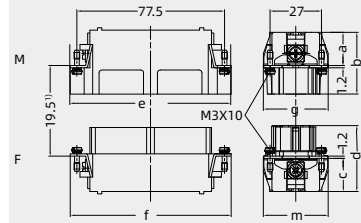

	a	b	e	g	c	d	f	m
M/F	18	32.5	84.5	34	18	34.5	84.5	34
MC/FC	18	33.5	84.5	34	18	35	84.5	34

Contact arrangement view from termination side

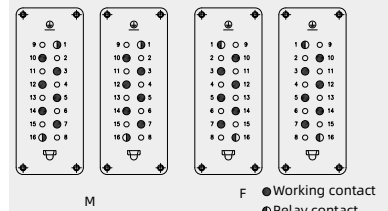

Panel cut out for inserts for use without hoods/housings

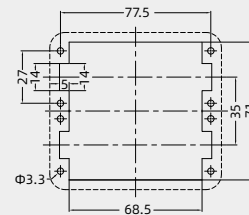

Crimp contacts

Crimp contacts 16A

16A Operating contacts
Contact resistance ≤ 1mΩ
silver plated



Relay contacts²⁾
silver plated



More crimp contacts 16A see P13-04.

Tools

Crimping tool



Contact removal tool



Male	Order No.	Female	Order No.
CESM-0.37	101 019 110 0301	CESF-0.37	101 019 120 0301
CESM-0.50	101 019 110 0401	CESF-0.50	101 019 120 0401
CESM-0.75	101 019 110 0601	CESF-0.75	101 019 120 0601
CESM-1.0	101 019 110 0801	CESF-1.0	101 019 120 0801
CESM-1.5	101 019 110 0901	CESF-1.5	101 019 120 0901
CESM-2.5	101 019 110 1001	CESF-2.5	101 019 120 1001
CESM-3.0	101 019 110 1101	CESF-3.0	101 019 120 1101
CESM-4.0	101 019 110 1201	CESF-4.0	101 019 120 1201

Wire gauge	Designation	Order No.
1	CESM-1.0R	101 019 110 0808
1.5	CESM-1.5R	101 019 110 0908
2.5	CESM-2.5R	101 019 110 1008

Wire gauge	Designation	Order No.
0.14-4mm ²	TL02G	198 001 001 0011

Application	Designation	Order No.
Wire gauge: 0.14-0.37mm ² please select TL02 Crimping tool.		
for crimp contacts 16A	TL01	198 001 000 0002

More tools detail please find the page 32-03~32-06.

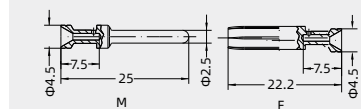

Identification	Wire gauge	Stripping length	
no groove	0.14-0.37 mm ²	AWG 26-22	7.5mm
no groove	0.5 mm ²	AWG 20	7.5mm
1 groove	0.75 mm ²	AWG 18	7.5mm
1 groove	1 mm ²	AWG 18	7.5mm
2 grooves	1.5 mm ²	AWG 16	7.5mm
3 grooves	2.5 mm ²	AWG 14	7.5mm
wide groove	3 mm ²	AWG 12	7.5mm
no groove	4 mm ²	AWG 12	7.5mm

When the wire gauge is less than 0.75mm², it's better to use the auxiliary pin assembly tool TL15.

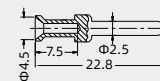

Notes: The tools for crimp terminal may influence the product quality and stability. Please select the tools recognized by our company.
2) Delay pin is relatively short, delay contact, protect circuit to avoid electric arc.

HVE-020 High voltage inserts

830V 16A 20+4+



Hoods/Housings: Screw terminal size WV48B/HV48B, please find the details on page 15-162.
Crimp terminal size 48B, please find the details on page 15-160~15-162.

Inserts

Screw terminal



Insert	Designation	Order No.
Male	HVE-010-M	124 010 011 0001
	HVE-010-M(11-20)	124 010 011 0002
Female	HVE-010-F	124 010 021 0001
	HVE-010-F(11-20)	124 010 021 0002

Crimp terminal

Order crimp contacts separately



Insert	Designation	Order No.
Male	HVE-010-MC	124 010 010 0001
	HVE-010-MC(11-20)	124 010 010 0002
Female	HVE-010-FC	124 010 020 0001
	HVE-010-FC(11-20)	124 010 020 0002

1) Distance for contact max. 21 mm

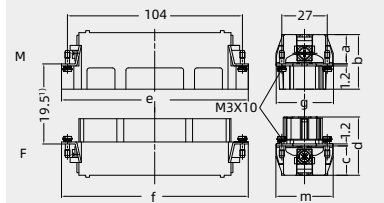

	a	b	e	g	c	d	f	m
M/F	17	32.5	111	33.5	17	34.5	111	33.5
MC/FC	18.3	33.5	111	34	18.3	35.5	111	34

Contact arrangement view from termination side

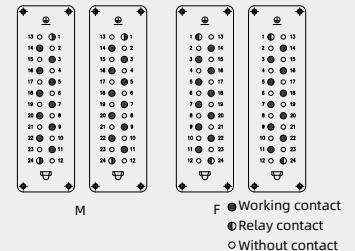

Panel cut out for inserts for use without hoods/housings

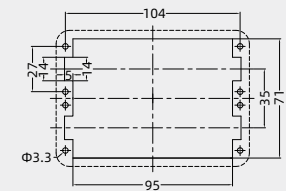

Crimp contacts

Crimp contacts 16A

16A Operating contacts
Contact resistance ≤ 1mΩ
silver plated



Relay contacts²⁾
silver plated



More crimp contacts 16A see P13-04.

Tools

Crimping tool



Contact removal tool



Male	Order No.	Female	Order No.
CESM-0.37	101 019 110 0301	CESF-0.37	101 019 120 0301
CESM-0.50	101 019 110 0401	CESF-0.50	101 019 120 0401
CESM-0.75	101 019 110 0601	CESF-0.75	101 019 120 0601
CESM-1.0	101 019 110 0801	CESF-1.0	101 019 120 0801
CESM-1.5	101 019 110 0901	CESF-1.5	101 019 120 0901
CESM-2.5	101 019 110 1001	CESF-2.5	101 019 120 1001
CESM-3.0	101 019 110 1101	CESF-3.0	101 019 120 1101
CESM-4.0	101 019 110 1201	CESF-4.0	101 019 120 1201

Wire gauge	Designation	Order No.
1	CESM-1.0R	101 019 110 0808
1.5	CESM-1.5R	101 019 110 0908
2.5	CESM-2.5R	101 019 110 1008

Wire gauge	Designation	Order No.
0.14-4mm ²	TL02G	198 001 001 0011

Application	Designation	Order No.
Wire gauge: 0.14-0.37mm ² please select TL02 Crimping tool.		
for crimp contacts 16A	TL01	198 001 000 0002

More tools detail please find the page 32-03~32-06.

Notes: The tools for crimp terminal may influence the product quality and stability. Please select the tools recognized by our company.
2) Delay pin is relatively short, delay contact, protect circuit to avoid electric arc.

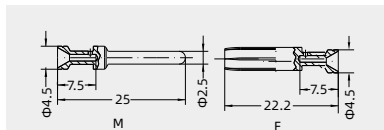

Identification	Wire gauge	Stripping length
no groove	0.14-0.37 mm ² AWG 26-22	7.5mm
no groove	0.5 mm ² AWG 20	7.5mm
1 groove	0.75 mm ² AWG 18	7.5mm
1 groove	1 mm ² AWG 18	7.5mm
2 grooves	1.5 mm ² AWG 16	7.5mm
3 grooves	2.5 mm ² AWG 14	7.5mm
wide groove	3 mm ² AWG 12	7.5mm
no groove	4 mm ² AWG 12	7.5mm

When the wire gauge is less than 0.75mm², it's better to use the auxiliary pin assembly tool TL15.

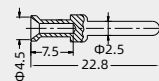

HVE-016 High voltage inserts

Technical characteristics

Specifications	DIN EN 60 664 DIN EN 61 984
Approvals	
Inserts	
Number of contacts	16,32+PE + 2 additional contacts for safe high voltage connections
Electrical data acc. to DIN EN 61 984	
-Rated current	16A
-Rated voltage conductor - ground	400V
-Rated voltage conductor - conductor	690V
-Rated impulse voltage	6kV
-Pollution degree	3
-or	16A 500V 6kV 3
Rated voltage acc. to UL	600V
Relay contacts	250V
Insulation resistance	$\geq 10^{10}\Omega$
Material	polycarbonate
Limiting temperatures	-40°C ...+125°C
Flammability acc. to UL 94	V0
Mechanical working life(mating cycles)	≥ 500
Contacts	
Material	copper alloy
Surface	hard-silver plated
Contact resistance	$\leq 1m\Omega$
Screw terminal	
-Wire gauge	2.5mm ²
-AWG	14
-Tightening/test torque	0.5Nm

Current carrying capacity

The current carrying is limited by maximum temperature of materials for inserts and contacts including terminals
Control and test procedures according to DIN EN 60512-5

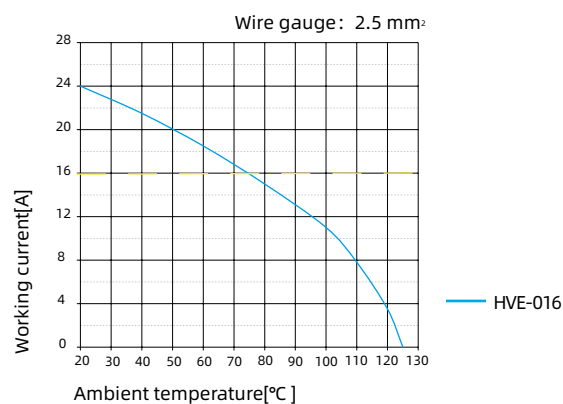
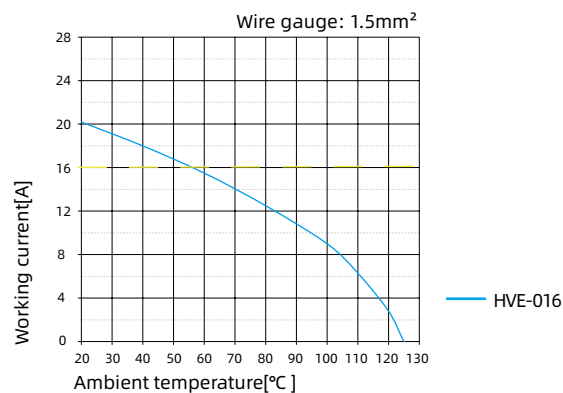

HVE-016 High voltage inserts

400V/690V 16A 16+2+ 



Inserts

Hoods/Housings: size **24B Plastic** or **WV24B/HV24B**, please find the details on page 15-108, 15-136~15-150.

Screw terminal



Insert	Designation	Order No.
Male	HVE-016-M	124 016 011 0001
Female	HVE-016-F	124 016 021 0001

1) Distance for contact max. 21 mm

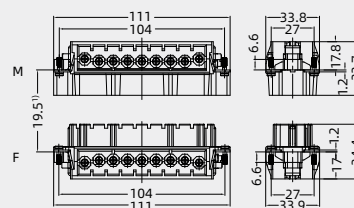

Contact arrangement view from termination side

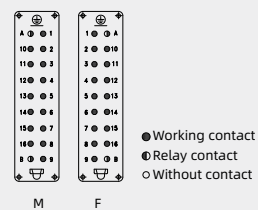

Panel cut out for inserts for use without hoods/housings

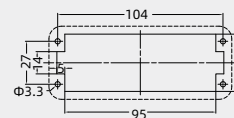

HVE-032 High voltage inserts

400V/690V 16A 32+4+ 



Inserts



Hoods/Housings: size **WV48B/HV48B**, please find the details on page 15-162.

Screw terminal



Insert	Designation	Order No.
Male	HVE-016-M	124 006 011 0001
	HVE-016-M(17-32)	124 006 011 0002
Female	HVE-016-F	124 006 021 0001
	HVE-016-F(17-32)	124 006 021 0002

1) Distance for contact max. 21 mm

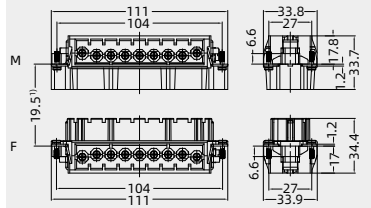

Contact arrangement view from termination side

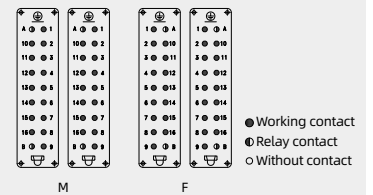

Panel cut out for inserts for use without hoods/housings

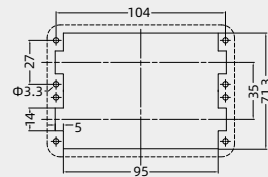

Difference between applicable housing and standard housing of HVE series

B standard Hoods/Housings

Coding bar



Special HVE Hoods/Housings

For HVE screw inserts, the screw inserts may be used together the corresponding HVE Hoods/Housings only.

Milled coding bar

Insulation tape

Coding pin





HVES SERIES

High voltage connector(spring piece connector)



HVES SERIES High voltage inserts

Technical characteristics

Specifications	DIN EN 60 664 DIN EN 61 984
Approvals	 ENEC
Inserts	
Number of contacts	3,6,10,12,20+PE
	+ 2 additional contacts for safe high voltage connections
Electrical data acc. to DIN EN 61 984	
-Rated current	16A
-Rated voltage	830V
-Rated impulse voltage	8kV
-Pollution degree	3
-Pollution degree 2 also	16A 1000V 8kV 2
-or	16A 720/1250V 8kV 2
-Relay contacts	16A 500V 6kV 3
Rated voltage acc. to UL	600V
Relay contacts	250V
Insulation resistance	$\geq 10^{10}\Omega$
Material	polycarbonate
Limiting temperatures	-40°C ...+125°C
Flammability acc. to UL 94	V0
Mechanical working life(mating cycles)	≥ 500
Contacts	
Material	copper alloy
Surface	hard-silver plated
Contact resistance	$\leq 3m\Omega$
Spring terminal	
-wire gauge	0.14-2.5mm ²
-AWG	26-14
-Stripping length	7-9mm

Current carrying capacity

The current carrying is limited by maximum temperature of materials for inserts and contacts including terminals

Control and test procedures according to DIN EN 60512-5

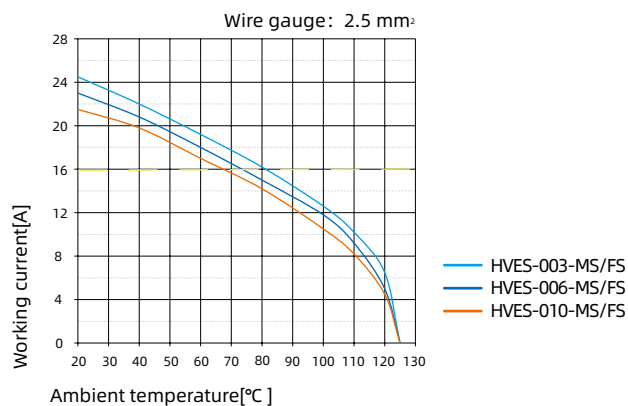
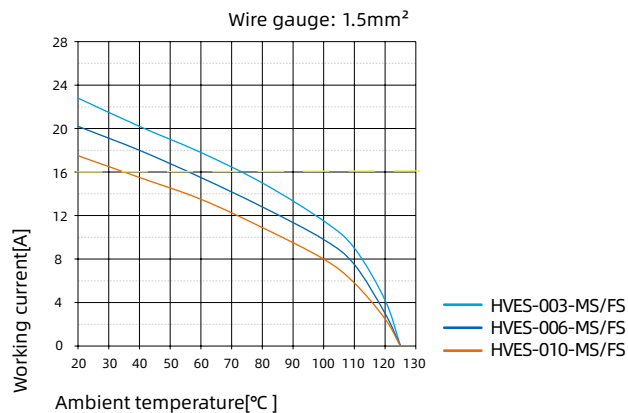

HVE-003 High voltage inserts

830V 16A 3+2+ 



Inserts

Hoods/Housings: size 10B, please find the details on page 15-39~15-69.

Spring terminal, See P00-14 for the structural characteristics of spring.



Insert	Designation	Order No.
Male	HVE-003-MS	124 003 012 0001
Female	HVE-003-FS	124 003 022 0001

1) Distance for contact max. 21 mm

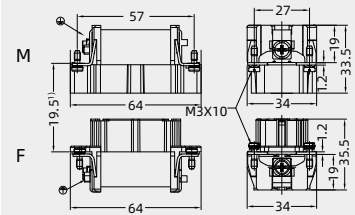

Contact arrangement view from termination side

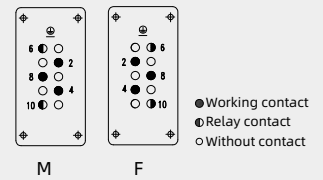

Panel cut out for inserts for use without hoods/housings

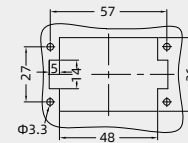

HVE-006 High voltage inserts

830V 16A 6+2+ 



Inserts

Hoods/Housings: size 16B, please find the details on page 15-70~15-1071.

Spring terminal, See P00-14 for the structural characteristics of spring.



Insert	Designation	Order No.
Male	HVE-006-MS	124 006 012 0001
Female	HVE-006-FS	124 006 022 0001

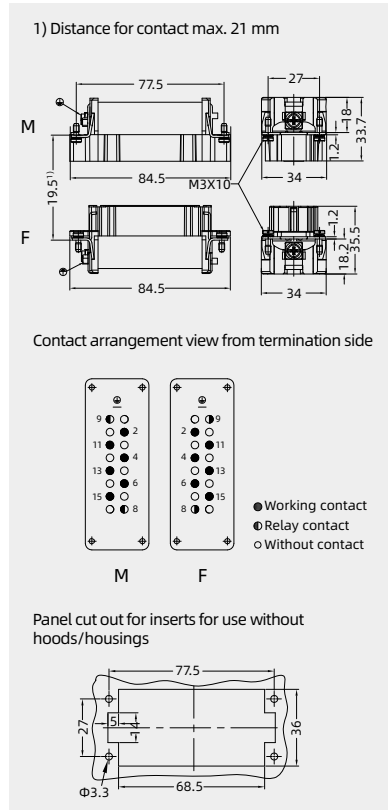

HVE-010 High voltage inserts

830V 16A 10+2+



Inserts

Hoods/Housings: size 24B, please find the details on page 15-108~15-150.

Spring terminal, See P00-14 for the structural characteristics of spring.



Insert	Designation	Order No.
Male	HVE-010-MS	124 010 012 0001
Female	HVE-010-FS	124 010 022 0001

1) Distance for contact max. 21 mm

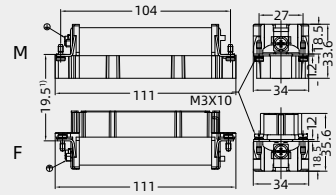

Contact arrangement view from termination side

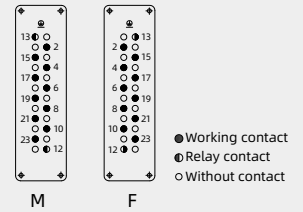

Panel cut out for inserts for use without hoods/housings

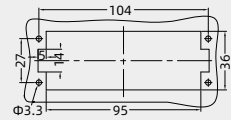

HVE-012 High voltage inserts

830V 16A 12+4+ 

ERC

Inserts



Hoods/Housings: size 32B, please find the details on page 15-151~15-159.

Spring terminal, See P00-14 for the structural characteristics of spring.



Insert	Designation	Order No.
Male	HVE-006-MS	124 006 012 0001
	HVE-006-MS(7-12)	124 006 012 0002
Female	HVE-006-FS	124 006 022 0001
	HVE-006-FS(7-12)	124 006 022 0002

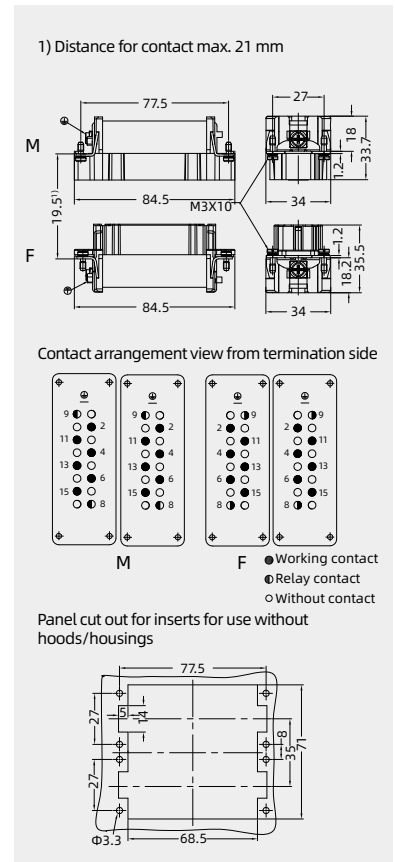

HVE-020 High voltage inserts

830V 16A 20+4+

ERC

Inserts



Hoods/Housings: size 48B, please find the details on page 15-160~15-162.

Spring terminal, See P00-14 for the structural characteristics of spring.



Insert	Designation	Order No.
Male	HVE-010-MS	124 010 012 0001
	HVE-010-MS(11-20)	124 010 012 0002
Female	HVE-010-FS	124 010 022 0001
	HVE-010-FS(11-20)	124 010 022 0002

1) Distance for contact max. 21 mm

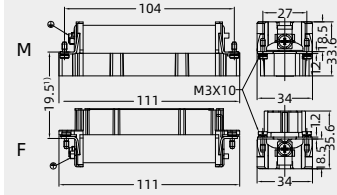

Contact arrangement view from termination side

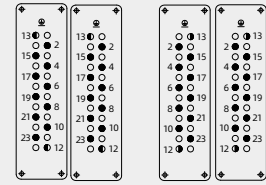

● Working contact
 ● Relay contact
 ○ Without contact

Panel cut out for inserts for use without hoods/housings

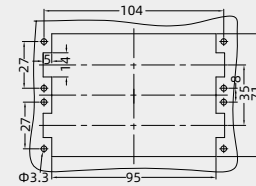



HEE SERIES

High density connector

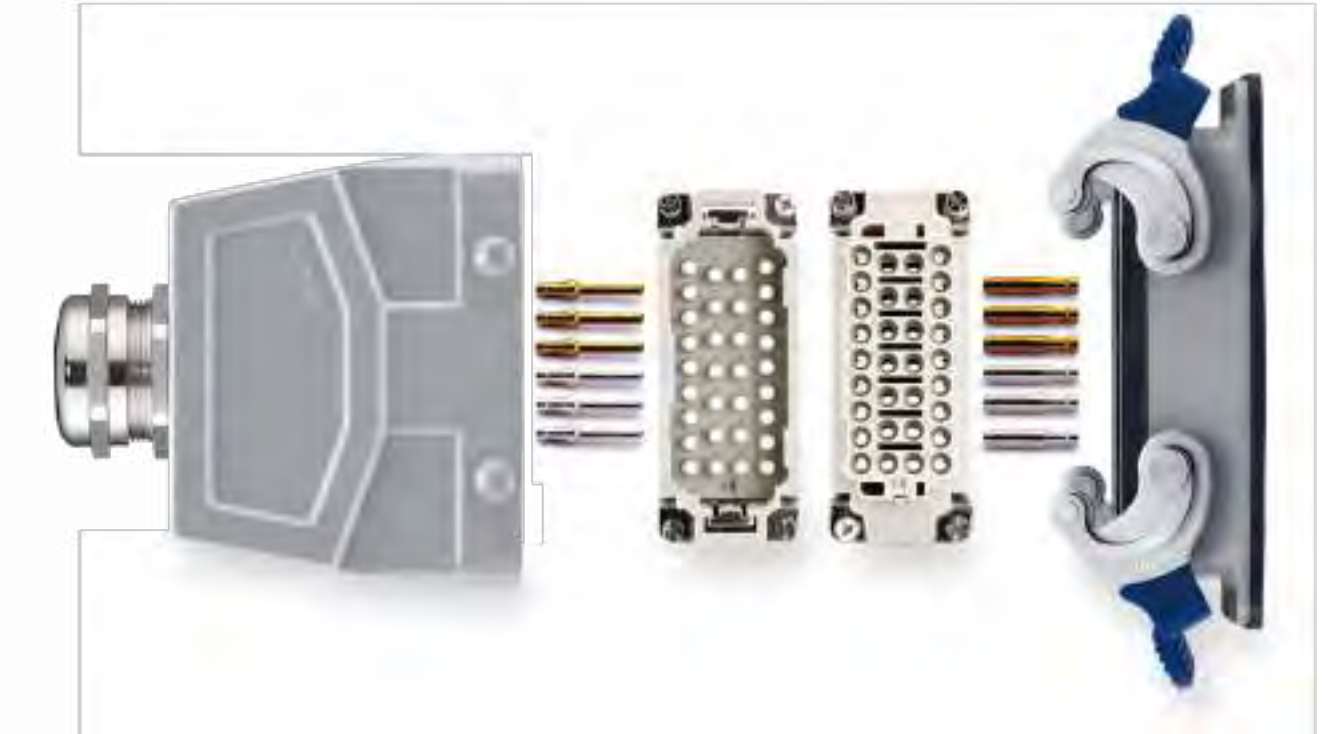

HEE SERIES High density inserts

Technical characteristics

Specifications	DIN EN 60 664 DIN EN 61 984
Approvals	
Inserts	
Number of contacts	10,18,32,40,46,64,64(2x32), 92(2x46)+PE
Electrical data acc. to EN 61 984	
-Rated current	16A
-Rated voltage	500V
-Rated impulse voltage	6kV
-Pollution degree	3
-Pollution degree 2 also	16A 830V 8kV 2
Rated voltage acc. to UL/CSA	600V
Insulation resistance	$\geq 10^{10}\Omega$
Material	polycarbonate
Limiting temperatures	-40°C ...+125°C
Flammability acc. to UL 94	V0
Mechanical working life(mating cycles)	≥ 500
Contacts	
Material	copper alloy
Surface	hard-gold plated hard-silver plated
Crimp terminal	
-Wire gauge	0.14-4.0mm ²
-AWG	26-12
-Stripping length	7.5mm
-Contact resistance	$\leq 1m\Omega$
Spring terminal(Quick-in)	
-Wire gauge	0.5-2.5mm ²
-AWG	20-14
-Stripping length	10 \pm 0.5mm
-Contact resistance	$\leq 3m\Omega$

Current carrying capacity

The current carrying is limited by maximum temperature of materials for inserts and contacts including terminals

Control and test procedures according to DIN EN 60512-5

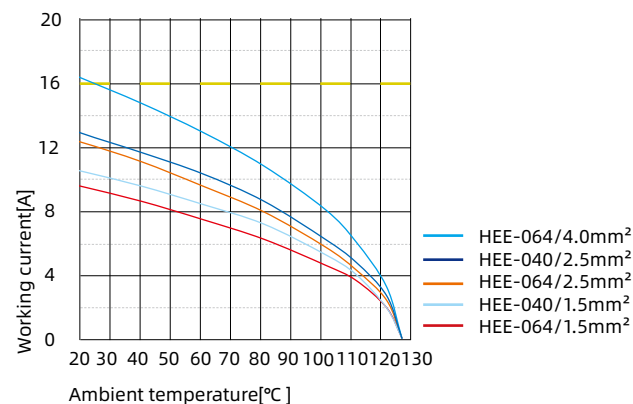
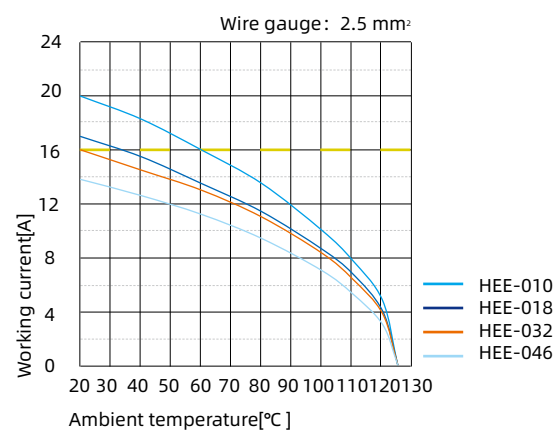
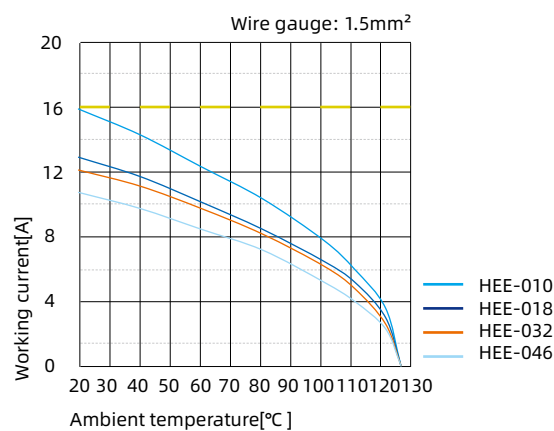

HEE Modified contact arrangement up to 1000 V

The connector series HEE equipped with all contacts may be used for voltages up to 500 V~ pollution degree 3. A modified contact loading arrangement permits use up to 1000 V ~ pollution degree 3 also in pollution degree C. Fully equipped connectors may also be used up to 1000 V ~ but in a lower pollution degree. According to DIN EN 61 984 connectors should not be coupled or decoupled under electrical load.

Contact arrangement view from termination side

690 V Pollution degree 3

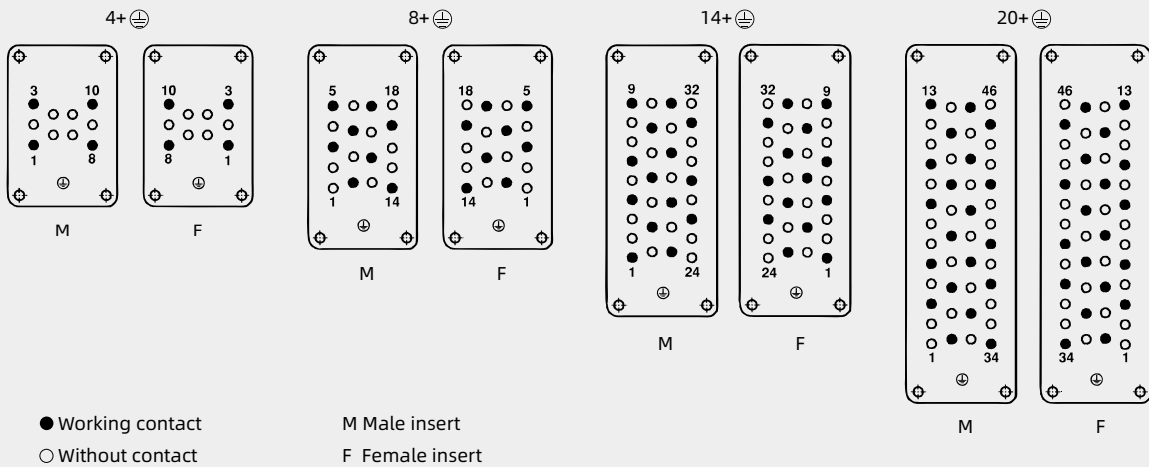

Contact arrangement view from termination side

1000 V Pollution degree 3

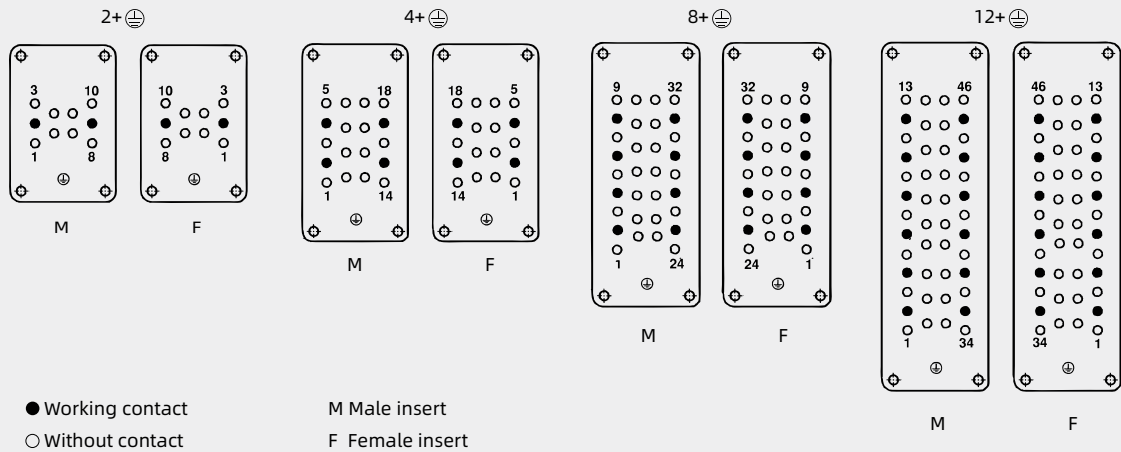

HEE-010 High density inserts

500V 16A 10+



Inserts

Hoods/Housings: size 6B, please find the details on page 15-25~15-38.2.

Crimp terminal

order crimp contacts separately



Insert	Designation	Order No.
Male	HEE-010-MC	123 010 010 0001
Female	HEE-010-FC	123 010 020 0001

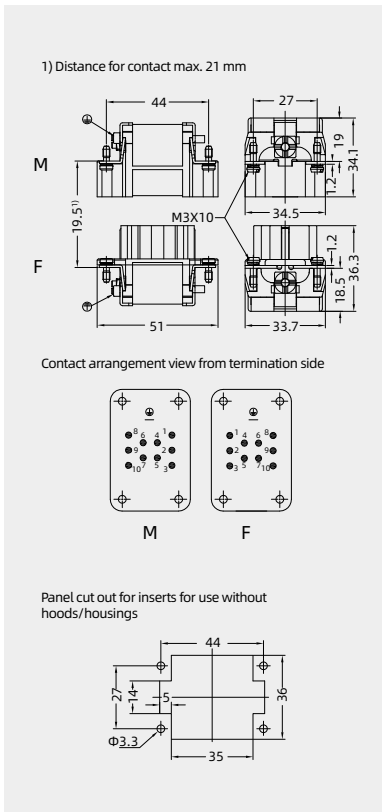

Crimp contacts

Crimp contacts 16A

Contact resistance ≤ 1mΩ silver plated



gold plated



Male	Order No.	Female	Order No.
CESM-0.37	101 019 110 0301	CESF-0.37	101 019 120 0301
CESM-0.50	101 019 110 0401	CESF-0.50	101 019 120 0401
CESM-0.75	101 019 110 0601	CESF-0.75	101 019 120 0601
CESM-1.0	101 019 110 0801	CESF-1.0	101 019 120 0801
CESM-1.5	101 019 110 0901	CESF-1.5	101 019 120 0901
CESM-2.5	101 019 110 1001	CESF-2.5	101 019 120 1001
CESM-3.0	101 019 110 1101	CESF-3.0	101 019 120 1101
CESM-4.0	101 019 110 1201	CESF-4.0	101 019 120 1201
CEGM-0.37	101 019 210 0301	CEGF-0.37	101 019 220 0301
CEGM-0.50	101 019 210 0401	CEGF-0.50	101 019 220 0401
CEGM-0.75	101 019 210 0601	CEGF-0.75	101 019 220 0601
CEGM-1.0	101 019 210 0801	CEGF-1.0	101 019 220 0801
CEGM-1.5	101 019 210 0901	CEGF-1.5	101 019 220 0901
CEGM-2.5	101 019 210 1001	CEGF-2.5	101 019 220 1001
CEGM-3.0	101 019 210 1101	CEGF-3.0	101 019 220 1101
CEGM-4.0	101 019 210 1201	CEGF-4.0	101 019 220 1201

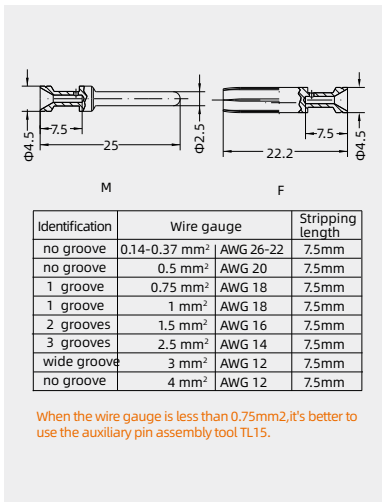

More crimp contacts 16A see P13-04.

Tools

Crimping tool



Contact removal tool



Wire gauge	Designation	Order No.
0.14-4mm ²	TL02G	198 001 001 0011
Wire gauge: 0.14-0.37mm ² please select TL02 Crimping tool.		
Application	Designation	Order No.
for crimp contacts 16A	TL01	198 001 000 0002
More tools detail please find the page 32-03-32-06.		

Notes: The tools for crimp terminal may influence the product quality and stability. Please select the tools recognized by our company.

HEE-018 High density inserts

500V 16A 18+



Inserts

Hoods/Housings: size 10B, detail please find the page15-39~15-69.

Crimp terminal

order crimp contacts separately



Insert	Designation	Order No.
Male	HEE-018-MC	123 018 010 0001
Female	HEE-018-FC	123 018 020 0001

1) Distance for contact max. 21 mm

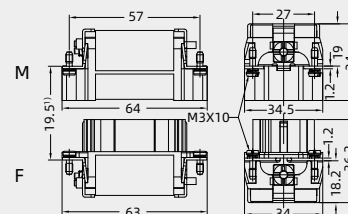

Contact arrangement view from termination side

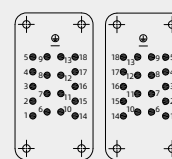

M F

Panel cut out for inserts for use without hoods/housings

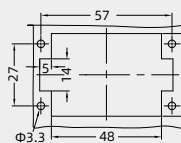

Crimp contacts

Crimp contacts 16A

Contact resistance $\leq 1m\Omega$
silver plated



gold plated



Male	Order No.	Female	Order No.
CESM-0.37	101 019 110 0301	CESF-0.37	101 019 120 0301
CESM-0.50	101 019 110 0401	CESF-0.50	101 019 120 0401
CESM-0.75	101 019 110 0601	CESF-0.75	101 019 120 0601
CESM-1.0	101 019 110 0801	CESF-1.0	101 019 120 0801
CESM-1.5	101 019 110 0901	CESF-1.5	101 019 120 0901
CESM-2.5	101 019 110 1001	CESF-2.5	101 019 120 1001
CESM-3.0	101 019 110 1101	CESF-3.0	101 019 120 1101
CESM-4.0	101 019 110 1201	CESF-4.0	101 019 120 1201
CEGM-0.37	101 019 210 0301	CEGF-0.37	101 019 220 0301
CEGM-0.50	101 019 210 0401	CEGF-0.50	101 019 220 0401
CEGM-0.75	101 019 210 0601	CEGF-0.75	101 019 220 0601
CEGM-1.0	101 019 210 0801	CEGF-1.0	101 019 220 0801
CEGM-1.5	101 019 210 0901	CEGF-1.5	101 019 220 0901
CEGM-2.5	101 019 210 1001	CEGF-2.5	101 019 220 1001
CEGM-3.0	101 019 210 1101	CEGF-3.0	101 019 220 1101
CEGM-4.0	101 019 210 1201	CEGF-4.0	101 019 220 1201

More crimp contacts 16A see P13-04.

Tools

Crimping tool



Contact removal tool



Wire gauge	Designation	Order No.
0.14-4mm ²	TL02G	198 001 001 0011
Wire gauge: 0.14-0.37mm ² please select TL02 Crimping tool.		
Application	Designation	Order No.
for crimp contacts 16A	TL01	198 001 000 0002

More tools detail please find the page32-03~32-06.

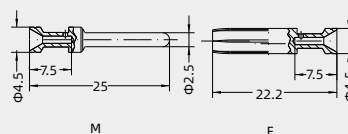

Identification	Wire gauge	Stripping length
no groove	0.14-0.37 mm ² AWG 26-22	7.5mm
no groove	0.5 mm ² AWG 20	7.5mm
1 groove	0.75 mm ² AWG 18	7.5mm
1 groove	1 mm ² AWG 18	7.5mm
2 grooves	1.5 mm ² AWG 16	7.5mm
3 grooves	2.5 mm ² AWG 14	7.5mm
wide groove	3 mm ² AWG 12	7.5mm
no groove	4 mm ² AWG 12	7.5mm

When the wire gauge is less than 0.75mm², it's better to use the auxiliary pin assembly tool TL15.

Notes: The tools for crimp terminal may influence the product quality and stability. Please select the tools recognized by our company.

HEE-032 High density inserts

500V 16A 32+



Inserts

Hoods/Housings: size **16B**, please find the details on page 15-70~15-1071.

Crimp terminal
order crimp contacts separately



Insert	Designation	Order No.
Male	HEE-032-MC	123 032 010 0001
Female	HEE-032-FC	123 032 020 0001

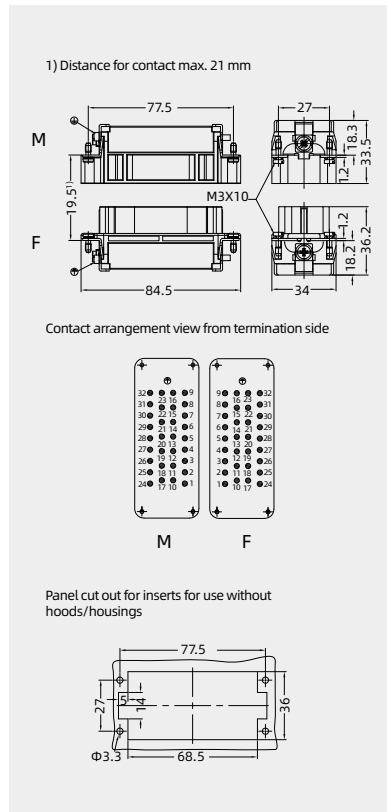

Crimp contacts

Crimp contacts 16A

Contact resistance $\leq 1m\Omega$
silver plated



gold plated



Male	Order No.	Female	Order No.
CESM-0.37	101 019 110 0301	CESF-0.37	101 019 120 0301
CESM-0.50	101 019 110 0401	CESF-0.50	101 019 120 0401
CESM-0.75	101 019 110 0601	CESF-0.75	101 019 120 0601
CESM-1.0	101 019 110 0801	CESF-1.0	101 019 120 0801
CESM-1.5	101 019 110 0901	CESF-1.5	101 019 120 0901
CESM-2.5	101 019 110 1001	CESF-2.5	101 019 120 1001
CESM-3.0	101 019 110 1101	CESF-3.0	101 019 120 1101
CESM-4.0	101 019 110 1201	CESF-4.0	101 019 120 1201
CEGM-0.37	101 019 210 0301	CEGF-0.37	101 019 220 0301
CEGM-0.50	101 019 210 0401	CEGF-0.50	101 019 220 0401
CEGM-0.75	101 019 210 0601	CEGF-0.75	101 019 220 0601
CEGM-1.0	101 019 210 0801	CEGF-1.0	101 019 220 0801
CEGM-1.5	101 019 210 0901	CEGF-1.5	101 019 220 0901
CEGM-2.5	101 019 210 1001	CEGF-2.5	101 019 220 1001
CEGM-3.0	101 019 210 1101	CEGF-3.0	101 019 220 1101
CEGM-4.0	101 019 210 1201	CEGF-4.0	101 019 220 1201

More crimp contacts 16A see P13-04.

Tools

Crimping tool



Contact removal tool



Wire gauge	Designation	Order No.
0.14-4mm ²	TL02G	198 001 001 0011
Wire gauge: 0.14-0.37mm ² please select TL02 Crimping tool.		
Application	Designation	Order No.
for crimp contacts 16A	TL01	198 001 000 0002

More tools detail please find the page 32-03-32-06.

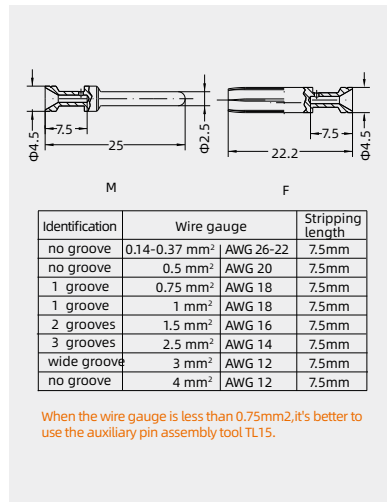

Notes: The tools for crimp terminal may influence the product quality and stability. Please select the tools recognized by our company.

HEE-046 High density inserts

500V 16A 46+



Inserts

Hoods/Housings: size 24B, please find the details on page 15-108~15-150.

Crimp terminal

order crimp contacts separately



Insert	Designation	Order No.
Male	HEE-046-MC	123 046 010 0011
Female	HEE-046-FC	123 046 020 0011
Male	HEE-046-MC/N ²⁾	123 046 010 0101
Female	HEE-046-FC/N ²⁾	123 046 020 0101

2) for crimp contacts 16A-Enhanced III, see page 13-04.

1) Distance for contact max. 21 mm

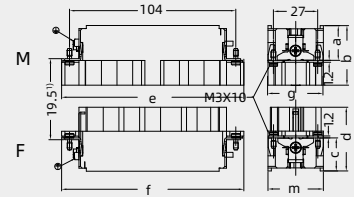

	a	b	e	g	c	d	f	m
M/F	18.5	33.8	110.5	34.4	18.3	36.2	110	34.4
MC/FC	18.3	33.8	110	34.4	18.2	36.2	110	34.4

Contact arrangement view from termination side

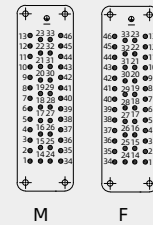

Panel cut out for inserts for use without hoods/housings

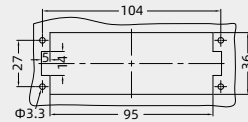

Crimp contacts

Crimp contacts 16A

Contact resistance ≤ 1mΩ
silver plated



gold plated



Male	Order No.	Female	Order No.
CESM-0.37	101 019 110 0301	CESF-0.37	101 019 120 0301
CESM-0.50	101 019 110 0401	CESF-0.50	101 019 120 0401
CESM-0.75	101 019 110 0601	CESF-0.75	101 019 120 0601
CESM-1.0	101 019 110 0801	CESF-1.0	101 019 120 0801
CESM-1.5	101 019 110 0901	CESF-1.5	101 019 120 0901
CESM-2.5	101 019 110 1001	CESF-2.5	101 019 120 1001
CESM-3.0	101 019 110 1101	CESF-3.0	101 019 120 1101
CESM-4.0	101 019 110 1201	CESF-4.0	101 019 120 1201
CEGM-0.37	101 019 210 0301	CEGF-0.37	101 019 220 0301
CEGM-0.50	101 019 210 0401	CEGF-0.50	101 019 220 0401
CEGM-0.75	101 019 210 0601	CEGF-0.75	101 019 220 0601
CEGM-1.0	101 019 210 0801	CEGF-1.0	101 019 220 0801
CEGM-1.5	101 019 210 0901	CEGF-1.5	101 019 220 0901
CEGM-2.5	101 019 210 1001	CEGF-2.5	101 019 220 1001
CEGM-3.0	101 019 210 1101	CEGF-3.0	101 019 220 1101
CEGM-4.0	101 019 210 1201	CEGF-4.0	101 019 220 1201

More crimp contacts 16A see P13-04.

Tools

Crimping tool



Contact removal tool

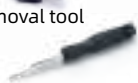

Wire gauge	Designation	Order No.
0.14-4mm ²	TL02G	198 001 001 0011
Wire gauge: 0.14-0.37mm ² please select TL02 Crimping tool.		
Application	Designation	Order No.
for crimp contacts 16A	TL01	198 001 000 0002

More tools detail please find the page 32-03~32-06.

Notes: The tools for crimp terminal may influence the product quality and stability. Please select the tools recognized by our company.

Identification	Wire gauge	Stripping length
no groove	0.14-0.37 mm ² AWG 26-22	7.5mm
no groove	0.5 mm ² AWG 20	7.5mm
1 groove	0.75 mm ² AWG 18	7.5mm
2 grooves	1 mm ² AWG 18	7.5mm
3 grooves	1.5 mm ² AWG 16	7.5mm
wide groove	2.5 mm ² AWG 14	7.5mm
no groove	3 mm ² AWG 12	7.5mm
no groove	4 mm ² AWG 12	7.5mm

When the wire gauge is less than 0.75mm², it's better to use the auxiliary pin assembly tool TL15.

HEE-046 Quick-in Module

500V 16A 46+ 

Inserts



Hoods/Housings: size 24B, please find the details on page 15-108~15-150.

Spring terminal (Quick-in)



Insert	Designation	Order No.
Male	HEE-046-MQ	123 046 001 0001
Female	HEE-046-FQ	123 046 002 0001

1) Distance for contact max. 21 mm

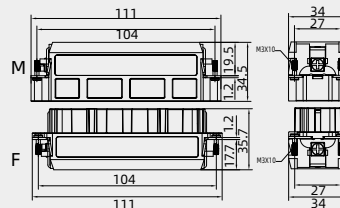

Contact arrangement view from termination side

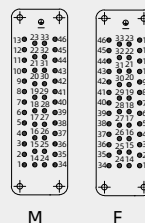

Panel cut out for inserts for use without hoods/housings

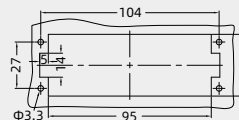

Coding element



Description	Designation	Order No.
coding, pokayoke	CODE-I	198 002 005 0035

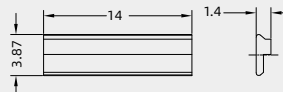

HEE-032x2 High density inserts

500V 16A 64+



Inserts

Hoods/Housings: size 32B, please find the details on page 15-151~15-159.

Crimp terminal

order crimp contacts separately



Insert	Designation	Order No.
Male	HEE-032-MC	123 032 010 0001
	HEE-032-MC(33-64)	123 032 010 0002
Female	HEE-032-FC	123 032 020 0001
	HEE-032-FC(33-64)	123 032 020 0002

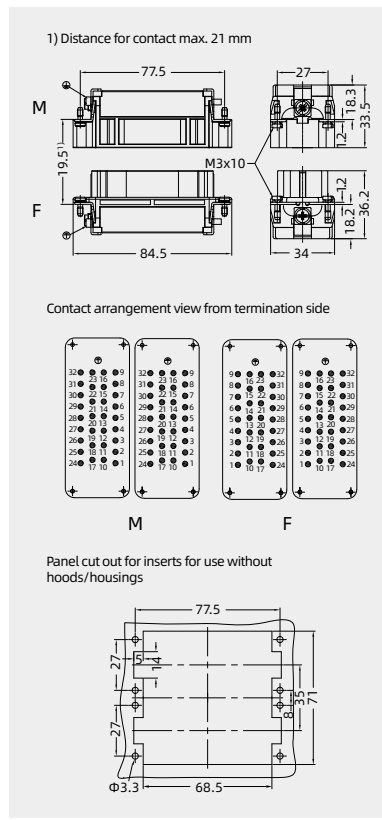

Crimp contacts

Crimp contacts 16A

Contact resistance ≤ 1mΩ
silver plated



gold plated



Male	Order No.	Female	Order No.
CESM-0.37	101 019 110 0301	CESF-0.37	101 019 120 0301
CESM-0.50	101 019 110 0401	CESF-0.50	101 019 120 0401
CESM-0.75	101 019 110 0601	CESF-0.75	101 019 120 0601
CESM-1.0	101 019 110 0801	CESF-1.0	101 019 120 0801
CESM-1.5	101 019 110 0901	CESF-1.5	101 019 120 0901
CESM-2.5	101 019 110 1001	CESF-2.5	101 019 120 1001
CESM-3.0	101 019 110 1101	CESF-3.0	101 019 120 1101
CESM-4.0	101 019 110 1201	CESF-4.0	101 019 120 1201
CEGM-0.37	101 019 210 0301	CEGF-0.37	101 019 220 0301
CEGM-0.50	101 019 210 0401	CEGF-0.50	101 019 220 0401
CEGM-0.75	101 019 210 0601	CEGF-0.75	101 019 220 0601
CEGM-1.0	101 019 210 0801	CEGF-1.0	101 019 220 0801
CEGM-1.5	101 019 210 0901	CEGF-1.5	101 019 220 0901
CEGM-2.5	101 019 210 1001	CEGF-2.5	101 019 220 1001
CEGM-3.0	101 019 210 1101	CEGF-3.0	101 019 220 1101
CEGM-4.0	101 019 210 1201	CEGF-4.0	101 019 220 1201

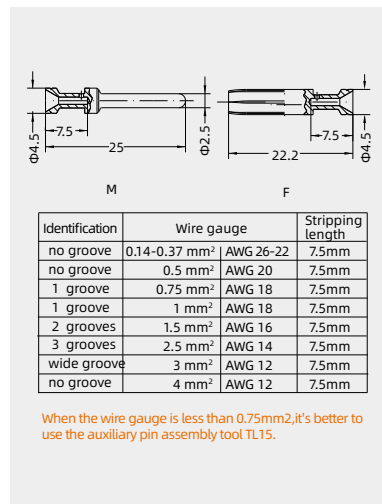

More crimp contacts 16A see P13-04.

Tools

Crimping tool



Contact removal tool



Wire gauge	Designation	Order No.
0.14-4mm ²	TL02G	198 001 001 0011
Wire gauge: 0.14-0.37mm ² please select TL02 Crimping tool.		
Application	Designation	Order No.
for crimp contacts 16A	TL01	198 001 000 0002

More tools detail please find the page 32-03~32-06.

Notes: The tools for crimp terminal may influence the product quality and stability. Please select the tools recognized by our company.

HEE-092 High density inserts

500V 16A 92+



Inserts

Hoods/Housings: size 48B, please find the details on page 15-160~15-162.

Crimp terminal

order crimp contacts separately



Insert	Designation	Order No.
Male	HEE-046-MC	123 046 010 0011
	HEE-046-MC(47-92)	123 046 010 0012
Female	HEE-046-FC	123 046 020 0011
	HEE-046-FC(47-92)	123 046 020 0012
Male	HEE-046-MC/N ²⁾	123 046 010 0101
	HEE-046-MC/N(47-92) ²⁾	123 046 010 0102
Female	HEE-046-FC/N ²⁾	123 046 020 0101
	HEE-046-FC/N(47-92) ²⁾	123 046 020 0102

2).for crimp contacts 16A-Enhanced III ,see page 13-04.

1) Distance for contact max. 21 mm

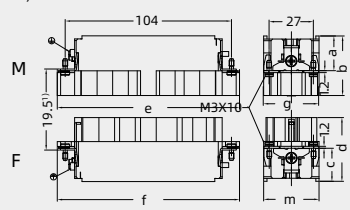

	a	b	e	g	c	d	f	m
M/F	18.5	33.8	110.5	34.4	18.3	36.2	110	34.4
MC/FC	18.3	33.8	110	34.4	18.2	36.2	110	34.4

Contact arrangement view from termination side

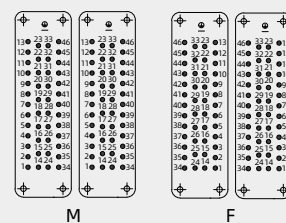

Panel cut out for inserts for use without hoods/housings

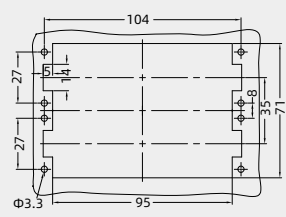

Crimp contacts

Crimp contacts 16A

Contact resistance ≤ 1mΩ silver plated



gold plated



Male	Order No.	Female	Order No.
CESM-0.37	101 019 110 0301	CESF-0.37	101 019 120 0301
CESM-0.50	101 019 110 0401	CESF-0.50	101 019 120 0401
CESM-0.75	101 019 110 0601	CESF-0.75	101 019 120 0601
CESM-1.0	101 019 110 0801	CESF-1.0	101 019 120 0801
CESM-1.5	101 019 110 0901	CESF-1.5	101 019 120 0901
CESM-2.5	101 019 110 1001	CESF-2.5	101 019 120 1001
CESM-3.0	101 019 110 1101	CESF-3.0	101 019 120 1101
CESM-4.0	101 019 110 1201	CESF-4.0	101 019 120 1201
CEGM-0.37	101 019 210 0301	CEGF-0.37	101 019 220 0301
CEGM-0.50	101 019 210 0401	CEGF-0.50	101 019 220 0401
CEGM-0.75	101 019 210 0601	CEGF-0.75	101 019 220 0601
CEGM-1.0	101 019 210 0801	CEGF-1.0	101 019 220 0801
CEGM-1.5	101 019 210 0901	CEGF-1.5	101 019 220 0901
CEGM-2.5	101 019 210 1001	CEGF-2.5	101 019 220 1001
CEGM-3.0	101 019 210 1101	CEGF-3.0	101 019 220 1101
CEGM-4.0	101 019 210 1201	CEGF-4.0	101 019 220 1201

More crimp contacts 16A see P13-04.

Tools

Crimping tool



Contact removal tool



Wire gauge	Designation	Order No.
0.14-4mm ²	TL02G	198 001 001 0011
Wire gauge: 0.14-0.37mm ² please select TL02 Crimping tool.		
Application	Designation	Order No.
for crimp contacts 16A	TL01	198 001 000 0002
More tools detail please find the page 32-03-32-06.		

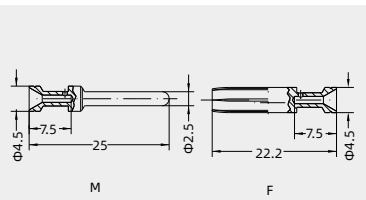

Identification	Wire gauge	Stripping length
no groove	0.14-0.37 mm ² AWG 26-22	7.5mm
no groove	0.5 mm ² AWG 20	7.5mm
1 groove	0.75 mm ² AWG 18	7.5mm
1 groove	1 mm ² AWG 18	7.5mm
2 grooves	1.5 mm ² AWG 16	7.5mm
3 grooves	2.5 mm ² AWG 14	7.5mm
wide groove	3 mm ² AWG 12	7.5mm
no groove	4 mm ² AWG 12	7.5mm

When the wire gauge is less than 0.75mm², it's better to use the auxiliary pin assembly tool TL15.

Notes: The tools for crimp terminal may influence the product quality and stability. Please select the tools recognized by our company.

HEE-040 High density inserts

500V 16A 40+



Inserts

Hoods/Housings: size 16B, please find the details on page 15-70~15-1071.

Crimp terminal

order crimp contacts separately



Insert	Designation	Order No.
Male	HEE-040-MC	123 040 010 0001
Female	HEE-040-FC	123 040 020 0001

1) Distance for contact max. 21 mm

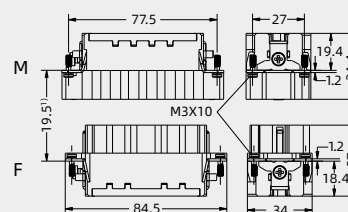

Contact arrangement view from termination side

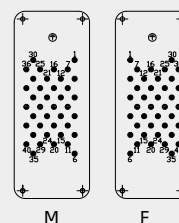

Panel cut out for inserts for use without hoods/housings

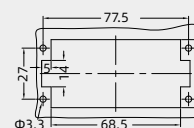

Crimp contacts

Crimp contacts 16A

Contact resistance $\leq 1m\Omega$
silver plated



gold plated



Male	Order No.	Female	Order No.
CESM-0.37	101 019 110 0301	CESF-0.37	101 019 120 0301
CESM-0.50	101 019 110 0401	CESF-0.50	101 019 120 0401
CESM-0.75	101 019 110 0601	CESF-0.75	101 019 120 0601
CESM-1.0	101 019 110 0801	CESF-1.0	101 019 120 0801
CESM-1.5	101 019 110 0901	CESF-1.5	101 019 120 0901
CESM-2.5	101 019 110 1001	CESF-2.5	101 019 120 1001
CESM-3.0	101 019 110 1101	CESF-3.0	101 019 120 1101
CESM-4.0	101 019 110 1201	CESF-4.0	101 019 120 1201
CEGM-0.37	101 019 210 0301	CEGF-0.37	101 019 220 0301
CEGM-0.50	101 019 210 0401	CEGF-0.50	101 019 220 0401
CEGM-0.75	101 019 210 0601	CEGF-0.75	101 019 220 0601
CEGM-1.0	101 019 210 0801	CEGF-1.0	101 019 220 0801
CEGM-1.5	101 019 210 0901	CEGF-1.5	101 019 220 0901
CEGM-2.5	101 019 210 1001	CEGF-2.5	101 019 220 1001
CEGM-3.0	101 019 210 1101	CEGF-3.0	101 019 220 1101
CEGM-4.0	101 019 210 1201	CEGF-4.0	101 019 220 1201

More crimp contacts 16A see P13-04.

Tools

Crimping tool



Contact removal tool



Wire gauge	Designation	Order No.
0.14-4mm ²	TL02G	198 001 001 0011
Wire gauge: 0.14-0.37mm ² please select TL02 Crimping tool.		
Application	Designation	Order No.
for crimp contacts 16A	TL01	198 001 000 0002

More tools detail please find the page 32-03~32-06.

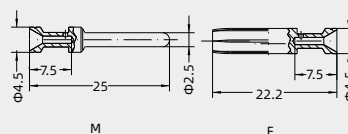

Identification	Wire gauge	Stripping length
no groove	0.14-0.37 mm ² AWG 26-22	7.5mm
no groove	0.5 mm ² AWG 20	7.5mm
1 groove	0.75 mm ² AWG 18	7.5mm
1 groove	1 mm ² AWG 18	7.5mm
2 grooves	1.5 mm ² AWG 16	7.5mm
3 grooves	2.5 mm ² AWG 14	7.5mm
wide groove	3 mm ² AWG 12	7.5mm
no groove	4 mm ² AWG 12	7.5mm

When the wire gauge is less than 0.75mm², it's better to use the auxiliary pin assembly tool TL15.

Notes: The tools for crimp terminal may influence the product quality and stability. Please select the tools recognized by our company.

HEE-064 High density inserts

500V 16A 64+ 



Inserts

Hoods/Housings: size 24B, please find the details on page 15-108~15-150.

Crimp terminal

order crimp contacts separately



Insert	Designation	Order No.
Male	HEE-064-MC	123 064 010 0001
Female	HEE-064-FC	123 064 020 0001

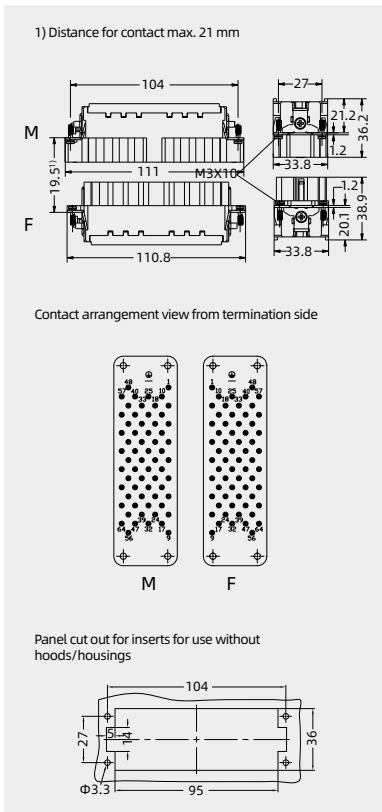

Crimp contacts

Crimp contacts 16A

Contact resistance $\leq 1m\Omega$
silver plated



gold plated



Male	Order No.	Female	Order No.
CESM-0.37	101 019 110 0301	CESF-0.37	101 019 120 0301
CESM-0.50	101 019 110 0401	CESF-0.50	101 019 120 0401
CESM-0.75	101 019 110 0601	CESF-0.75	101 019 120 0601
CESM-1.0	101 019 110 0801	CESF-1.0	101 019 120 0801
CESM-1.5	101 019 110 0901	CESF-1.5	101 019 120 0901
CESM-2.5	101 019 110 1001	CESF-2.5	101 019 120 1001
CESM-3.0	101 019 110 1101	CESF-3.0	101 019 120 1101
CESM-4.0	101 019 110 1201	CESF-4.0	101 019 120 1201
CEGM-0.37	101 019 210 0301	CEGF-0.37	101 019 220 0301
CEGM-0.50	101 019 210 0401	CEGF-0.50	101 019 220 0401
CEGM-0.75	101 019 210 0601	CEGF-0.75	101 019 220 0601
CEGM-1.0	101 019 210 0801	CEGF-1.0	101 019 220 0801
CEGM-1.5	101 019 210 0901	CEGF-1.5	101 019 220 0901
CEGM-2.5	101 019 210 1001	CEGF-2.5	101 019 220 1001
CEGM-3.0	101 019 210 1101	CEGF-3.0	101 019 220 1101
CEGM-4.0	101 019 210 1201	CEGF-4.0	101 019 220 1201

More crimp contacts 16A see P13-04.

Tools

Crimping tool



Contact removal tool



Wire gauge	Designation	Order No.
0.14-4mm ²	TL02G	198 001 001 0011
Wire gauge: 0.14-0.37mm ² please select TL02 Crimping tool.		
Application	Designation	Order No.
for crimp contacts 16A	TL01	198 001 000 0002

More tools detail please find the page 32-03-32-06.

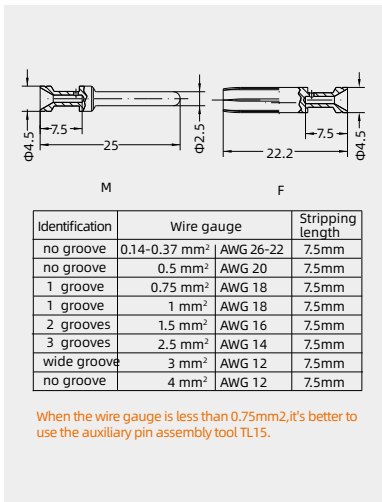

Notes: The tools for crimp terminal may influence the product quality and stability. Please select the tools recognized by our company.

HEEE SERIES

Ultra high density type insert



HEEE SERIES ultra high density type insert



Technical characteristics

Specifications	DIN EN 60 664	DIN EN 61 984
Approvals		
Inserts		
Number of contacts	32+PE,72+PE	
Electrical data acc. to EN 61 984		
-Rated current	16A	
-Rated voltage	400V	
-Rated impulse voltage	6kV	
-Pollution degree	3	
Insulation resistance	$\geq 10^{10}\Omega$	
Material	polycarbonate	
Limiting temperatures	-40°C ...+125°C	
Flammability acc. to UL 94	V0	
Mechanical working life(mating cycles)	≥ 500	
Contacts		
Material	copper alloy	
Surface	hard-gold plated hard-silver plated	
Contact resistance	$\leq 1\text{m}\Omega$	
Crimp terminal		
-Wire gauge	0.14-4.0mm ²	
-AWG	26-12	
-Stripping length	7.5mm	
Tools		
Crimping tool	TL02G(0.5-4mm ²) TL02(0.14-0.37mm ²)	
Contact removal tool	TL01	

HEEE-032 Ultra high density type insert

400V 16A 32+



Inserts

Hoods/Housings: size 10B, please find the details on page 15-39~15-69.

Crimp terminal

order crimp contacts separately



Insert	Designation	Order No.
Male	HEEE-032-MC	136 032 010 0001
Female	HEEE-032-FC	136 032 020 0001

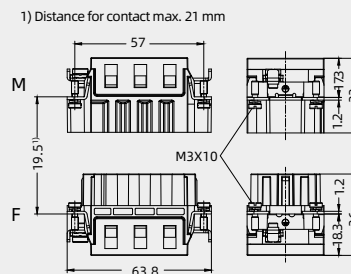

Contact arrangement view from termination side

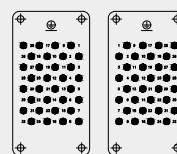

M F

Panel cut out for inserts for use without hoods/housings

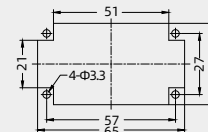

Crimp contacts

Crimp contacts 16A

Contact resistance $\leq 1m\Omega$
silver plated



gold plated



Male	Order No.	Female	Order No.
CESM-0.37	101 019 110 0301	CESF-0.37	101 019 120 0301
CESM-0.50	101 019 110 0401	CESF-0.50	101 019 120 0401
CESM-0.75	101 019 110 0601	CESF-0.75	101 019 120 0601
CESM-1.0	101 019 110 0801	CESF-1.0	101 019 120 0801
CESM-1.5	101 019 110 0901	CESF-1.5	101 019 120 0901
CESM-2.5	101 019 110 1001	CESF-2.5	101 019 120 1001
CESM-3.0	101 019 110 1101	CESF-3.0	101 019 120 1101
CESM-4.0	101 019 110 1201	CESF-4.0	101 019 120 1201
CEGM-0.37	101 019 210 0301	CEGF-0.37	101 019 220 0301
CEGM-0.50	101 019 210 0401	CEGF-0.50	101 019 220 0401
CEGM-0.75	101 019 210 0601	CEGF-0.75	101 019 220 0601
CEGM-1.0	101 019 210 0801	CEGF-1.0	101 019 220 0801
CEGM-1.5	101 019 210 0901	CEGF-1.5	101 019 220 0901
CEGM-2.5	101 019 210 1001	CEGF-2.5	101 019 220 1001
CEGM-3.0	101 019 210 1101	CEGF-3.0	101 019 220 1101
CEGM-4.0	101 019 210 1201	CEGF-4.0	101 019 220 1201

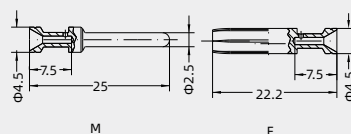

M F

Identification	Wire gauge	Stripping length
no groove	0.14-0.37 mm ² AWG 26-22	7.5mm
no groove	0.5 mm ² AWG 20	7.5mm
1 groove	0.75 mm ² AWG 18	7.5mm
1 groove	1 mm ² AWG 18	7.5mm
2 grooves	1.5 mm ² AWG 16	7.5mm
3 grooves	2.5 mm ² AWG 14	7.5mm
wide groove	3 mm ² AWG 12	7.5mm
no groove	4 mm ² AWG 12	7.5mm

When the wire gauge is less than 0.75mm², it's better to use the auxiliary pin assembly tool TL15.

More crimp contacts 16A see P13-04.

Tools

Crimping tool



Contact removal tool



Wire gauge	Designation	Order No.
0.14-4mm ²	TL02G	198 001 001 0011
Wire gauge: 0.14-0.37mm ² please select TL02 Crimping tool.		
Application	Designation	Order No.
for crimp contacts 16A	TL01	198 001 000 0002
More tools detail please find the page 32-03~32-06.		

Notes: The tools for crimp terminal may influence the product quality and stability. Please select the tools recognized by our company.

HD HDD SERIES

Ultra-high density connector

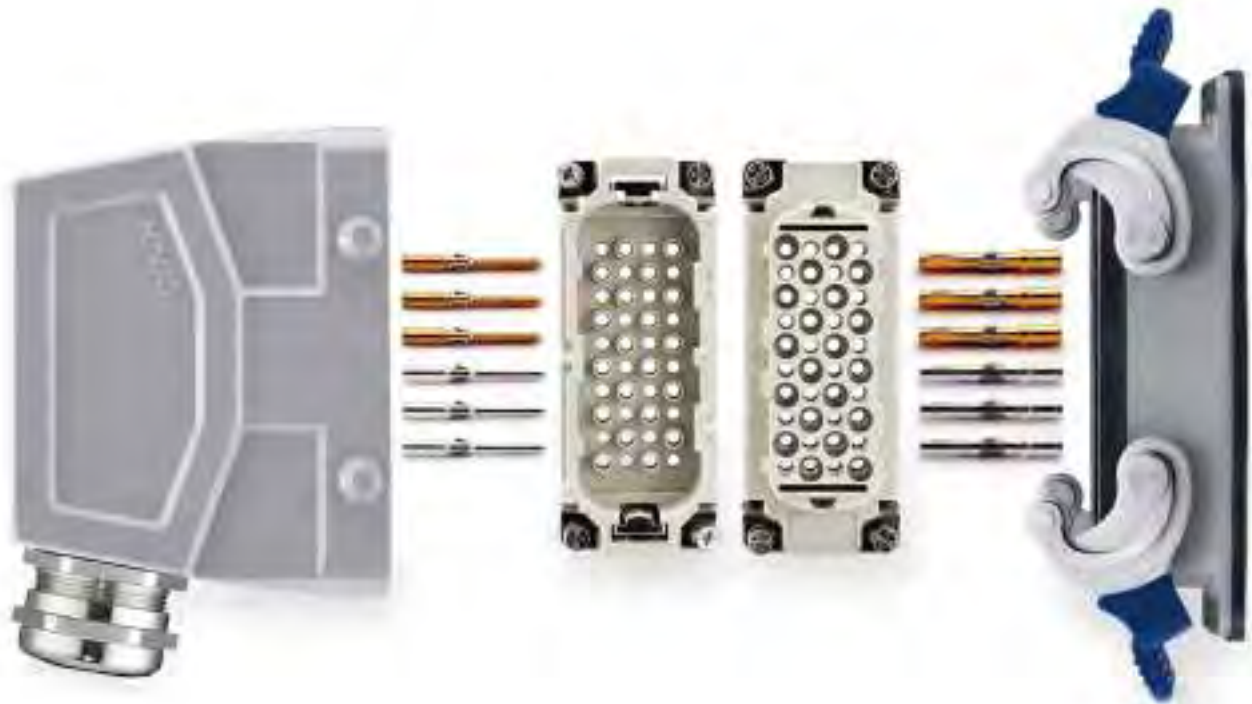

HD SERIES Ultra-high density inserts

Technical characteristics

Specifications	DIN EN 60 664 DIN EN 61 984
Approvals	
Inserts	
Number of contacts	7,8,15,25,40,50(25x2),64,80(40x2), 128(64x2)+PE
Electrical data acc. to EN 61 984	
-Rated current	10A
-Rated voltage	250V
-Rated impulse voltage	4kV
-Pollution degree	3
-Pollution degree 2 also	10A 230/400V 4kV 2
-Rated voltage acc. to UL	600V
HD-008 Electrical data	
-Rated current	10A
-Rated voltage	~50V/-120V
-Rated impulse voltage	0.8kV
-Pollution degree	3
-Rated voltage acc. to UL	50V
-Rated voltage(direct voltage)	120V
Insulation resistance	$\geq 10^{10}\Omega$
Material	polycarbonate
Limiting temperatures	-40°C ...+125°C
Flammability acc. to UL 94	V0
Mechanical working life(mating cycles)	≥ 500
Contacts	
Material	copper alloy
Surface	hard-gold plated hard-silver plated
Contact resistance	$\leq 3m\Omega$
Crimp terminal	
-Wire gauge	0.14-2.5mm ²
-AWG	26-14
Stamped contacts	
Material	copper alloy
Surface	hard-silver plated
Contact resistance	$\leq 5m\Omega$
Crimp terminal	
-Wire gauge	0.5-1.5mm ² /1.5-2.5mm ²
-AWG	20-16/16-14
-Stripping length	6mm

Current carrying capacity

The current carrying is limited by maximum temperature of materials for inserts and contacts including terminals

Control and test procedures according to DIN EN 60512-5

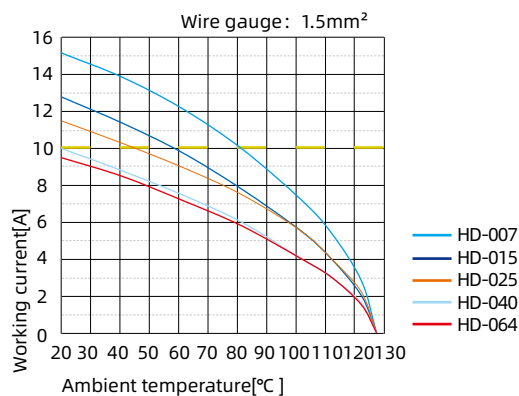
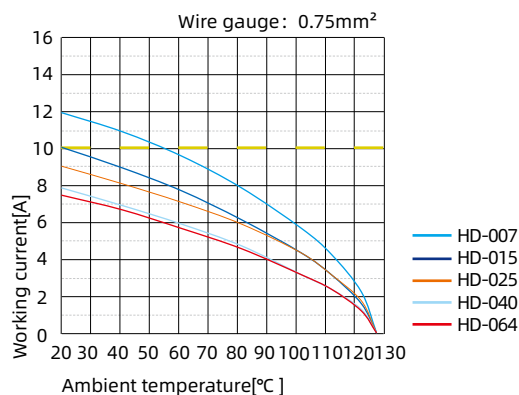

Stamped contacts:

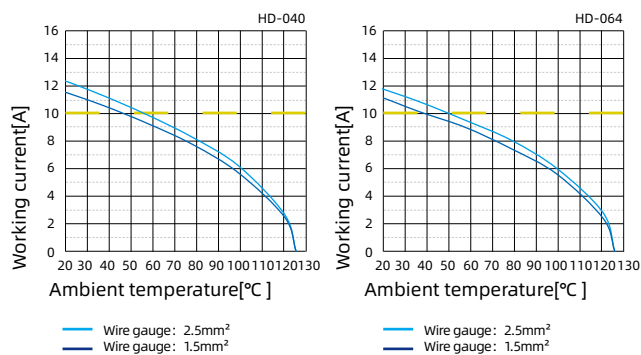

HDD SERIES Ultra-high density inserts

Technical characteristics

Specifications	DIN EN 60 664 DIN EN 61 984
Approvals	
Inserts	
Number of contacts	24,42,72,108,144(72x2), 216(108x2)+PE
Electrical data acc. to EN 61 984	
-Rated current	10A
-Rated voltage	250V
-Rated impulse voltage	4kV
-Pollution degree	3
-Pollution degree 2 also	10A 230/400V 4kV 2
Rated voltage acc. to UL	600V
Insulation resistance	$\geq 10^{10}\Omega$
Material	polycarbonate
Limiting temperatures	-40°C ...+125°C
Flammability acc. to UL 94	V0
Mechanical working life(mating cycles) \geq 500	
Contacts	
Material	copper alloy
Surface	hard-gold plated hard-silver plated
Contact resistance	$\leq 3m\Omega$
Crimp terminal	
-Wire gauge	0.14-2.5mm ²
-AWG	26-14

Current carrying capacity

The current carrying is limited by maximum temperature of materials for inserts and contacts including terminals

Control and test procedures according to DIN EN 60512-5

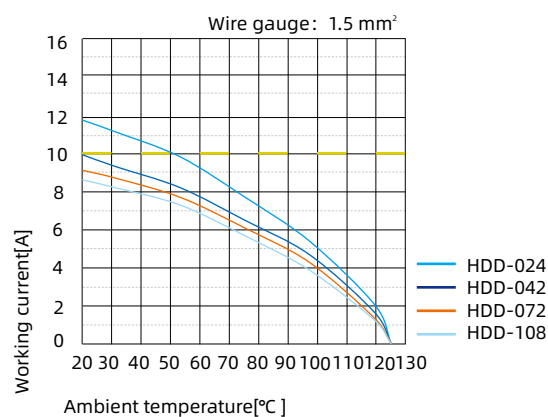
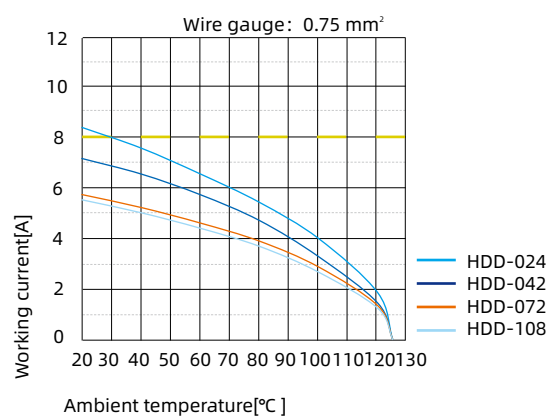

HD HDD Modified contact arrangement up to 500 V

The connector series HDD and HD equipped with all contacts may be used for voltages up to 250 V, pollution degree 3. A modified contact loading arrangement permits use up to 500 V also in the same pollution degree. According to DIN EN 61 984 connectors should not be coupled or decoupled under electrical load.

Contact arrangement view from termination side

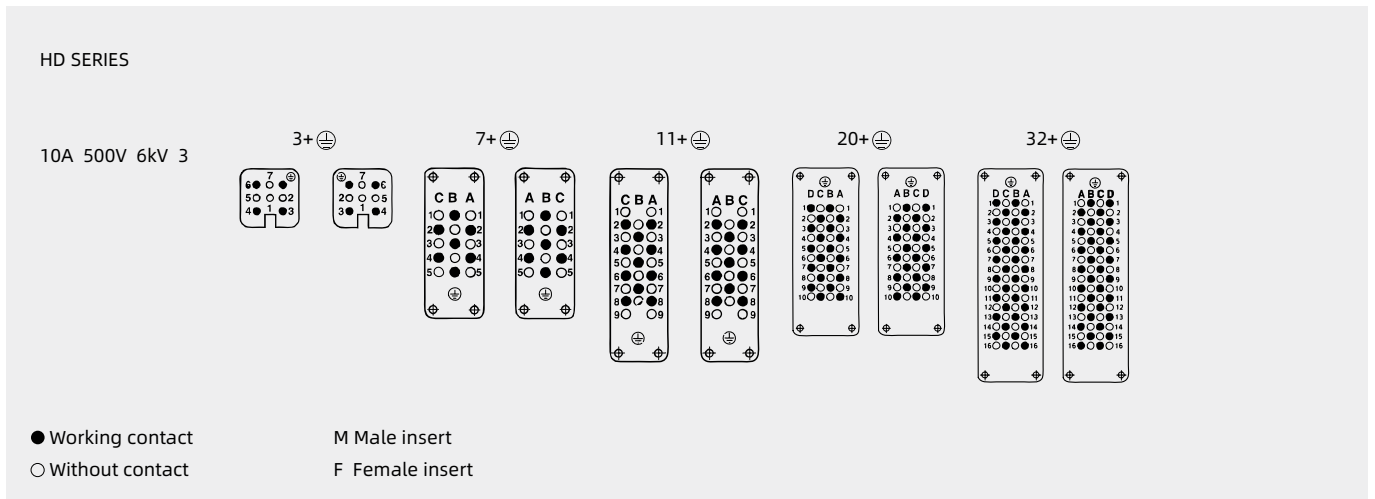

Contact arrangement view from termination side

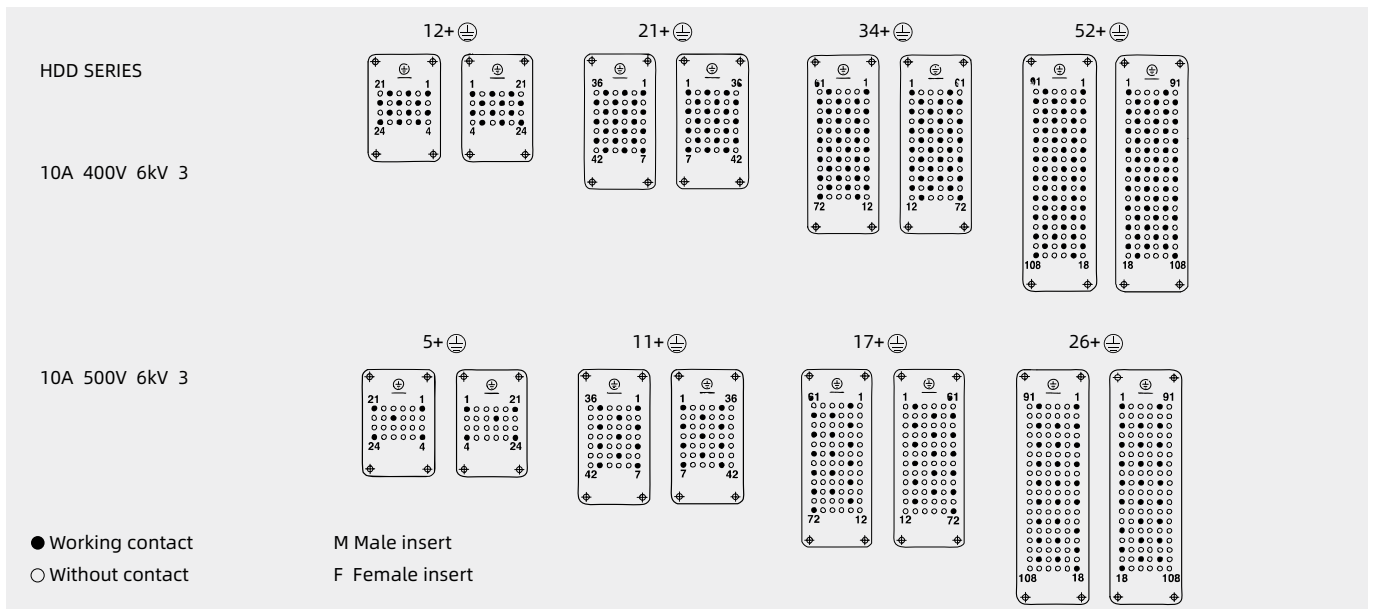

HD-007 Ultra-high density inserts

250V 10A 7+



Inserts

Hoods/Housings: **size 3A(only for plastic)**, please find the details on page 15-06~15-07.

Crimp terminal

order crimp contacts separately



Insert	Designation	Order No.
Male	HD-007-MC	125 007 010 0001
Female	HD-007-FC	125 007 020 0001

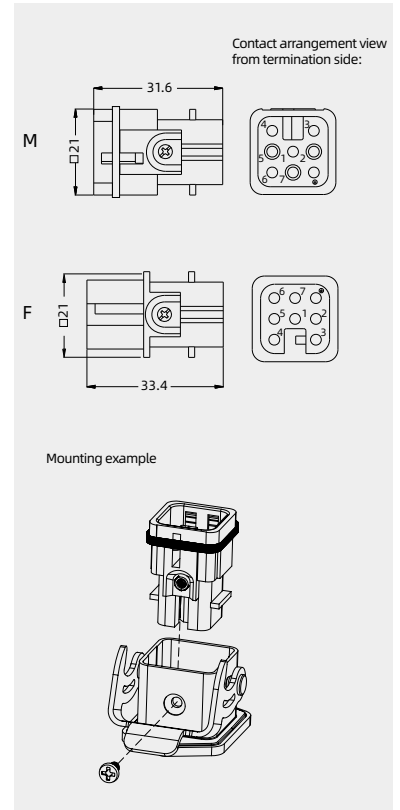

Crimp contacts

Crimp contacts 10A

Contact resistance $\leq 3m\Omega$
silver plated



gold plated



More crimp contacts 10A
see P13-02,P13-03.

Tools

Crimping tool



Contact removal tool

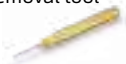

Male	Order No.	Female	Order No.
CDSM-0.25	101 017 110 0101	CDSF-0.25	101 017 120 0101
CDSM-0.37	101 017 110 0301	CDSF-0.37	101 017 120 0301
CDSM-0.50	101 017 110 0401	CDSF-0.50	101 017 120 0401
CDSM-0.75	101 017 110 0601	CDSF-0.75	101 017 120 0601
CDSM-1.0	101 017 110 0801	CDSF-1.0	101 017 120 0801
CDSM-1.5	101 017 110 0901	CDSF-1.5	101 017 120 0901
CDSM-2.5	101 017 110 1001	CDSF-2.5	101 017 120 1001

Male	Order No.	Female	Order No.
CDGM-0.25	101 017 210 0101	CDGF-0.25	101 017 220 0101
CDGM-0.37	101 017 210 0301	CDGF-0.37	101 017 220 0301
CDGM-0.50	101 017 210 0401	CDGF-0.50	101 017 220 0401
CDGM-0.75	101 017 210 0601	CDGF-0.75	101 017 220 0601
CDGM-1.0	101 017 210 0801	CDGF-1.0	101 017 220 0801
CDGM-1.5	101 017 210 0901	CDGF-1.5	101 017 220 0901
CDGM-2.5	101 017 210 1001	CDGF-2.5	101 017 220 1001

Wire gauge	Designation	Order No.
0.14-4mm ²	TL02G	198 001 001 0011

For the crimping contacts and removing contacts
instructions, please find the page 06-23~06-24.

Application	Designation	Order No.
for crimp contacts 10A	TL00	198 001 000 0001

More tools detail please find the page 32-03~32-06.

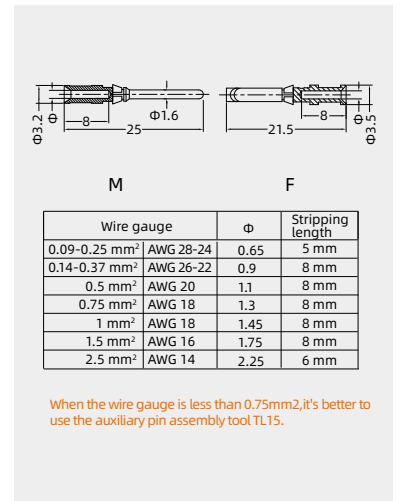

When the wire gauge is less than 0.75mm², it's better to use the auxiliary pin assembly tool TL15.

Notes: The tools for crimp terminal may influence the product quality and stability.
Please select the tools recognized by our company.

HD-008 Ultra-high density inserts

-120V/~50V 10A 8



Inserts

Hoods/Housings: **size 3A**, please find the details on page 15-06~15-16.1.

Crimp terminal

order crimp contacts separately



Insert	Designation	Order No.
Male	HD-008-MC	125 008 010 0001
Female	HD-008-FC	125 008 020 0001

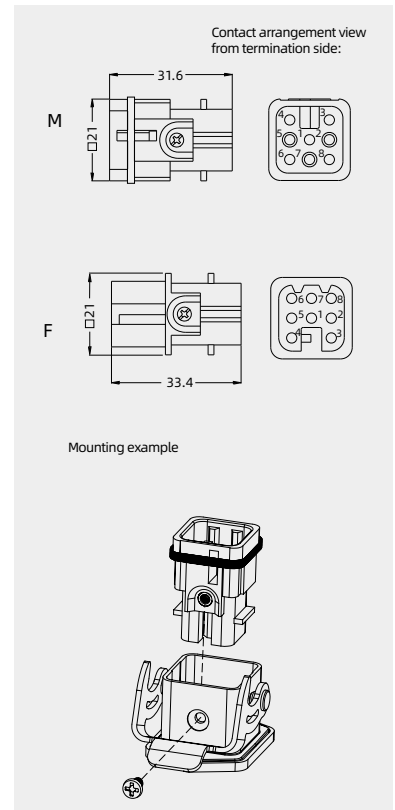

Crimp contacts

Crimp contacts 10A

Contact resistance $\leq 3m\Omega$
silver plated



gold plated



More crimp contacts 10A
see P13-02,P13-03.

Male	Order No.	Female	Order No.
CDSM-0.25	101 017 110 0101	CDSF-0.25	101 017 120 0101
CDSM-0.37	101 017 110 0301	CDSF-0.37	101 017 120 0301
CDSM-0.50	101 017 110 0401	CDSF-0.50	101 017 120 0401
CDSM-0.75	101 017 110 0601	CDSF-0.75	101 017 120 0601
CDSM-1.0	101 017 110 0801	CDSF-1.0	101 017 120 0801
CDSM-1.5	101 017 110 0901	CDSF-1.5	101 017 120 0901
CDSM-2.5	101 017 110 1001	CDSF-2.5	101 017 120 1001

Male	Order No.	Female	Order No.
CDGM-0.25	101 017 210 0101	CDGF-0.25	101 017 220 0101
CDGM-0.37	101 017 210 0301	CDGF-0.37	101 017 220 0301
CDGM-0.50	101 017 210 0401	CDGF-0.50	101 017 220 0401
CDGM-0.75	101 017 210 0601	CDGF-0.75	101 017 220 0601
CDGM-1.0	101 017 210 0801	CDGF-1.0	101 017 220 0801
CDGM-1.5	101 017 210 0901	CDGF-1.5	101 017 220 0901
CDGM-2.5	101 017 210 1001	CDGF-2.5	101 017 220 1001

Tools

Crimping tool



Contact removal tool

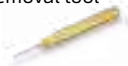

Wire gauge	Designation	Order No.
0.14-4mm ²	TL02G	198 001 001 0011

For the crimping contacts and removing contacts instructions, please find the page 06-23~06-24.

Application	Designation	Order No.
for crimp contacts 10A	TL00	198 001 000 0001

More tools detail please find the page 32-03~32-06.

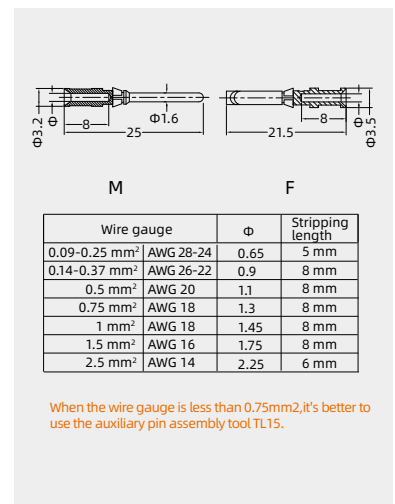

Notes: The tools for crimp terminal may influence the product quality and stability. Please select the tools recognized by our company.

HD-008 Quick-in



Technical specification

Specifications	DIN EN 60 664 DIN EN 61 984
Approvals	
Inserts	
Number of contacts	8
Electrical data acc. to EN 61 984	
-Rated current	10A
-Rated voltage	50/~120V
-Rated impulse voltage	0.8kV
-Pollution degree	3
Insulation resistance	$\geq 10^{10}\Omega$
Material	polycarbonate
Colour	RAL 7032(light grey)
Limiting temperatures	-40°C ...+125°C
Flammability acc. to UL 94	V0
Mechanical working life(mating cycles) ≥ 500	
Contacts	
Terminal	spring terminal(Quick-in)
Material	copper alloy
Surface	silver plated
Contact resistance	$\leq 3m\Omega$
Crimp terminal	
-Wire gauge	0.5-2.5mm ²
-AWG	20-14
(For wires with crimped ferrule)	
-Wire gauge	0.14-1.5mm ²
-AWG	26-16
Stripping length	10±0.5mm

HD-008 Qulck-in

50V /~120V 10A 8

Inserts

Hoods/Housings: size 3A, please find the details on page 15-06~15-16.1.

Spring Terminal(Quick-in)



Insert	Designation	Order No.
Male	HD-008-MQ	125 008 001 0001
Female	HD-008-FQ	125 008 002 0001

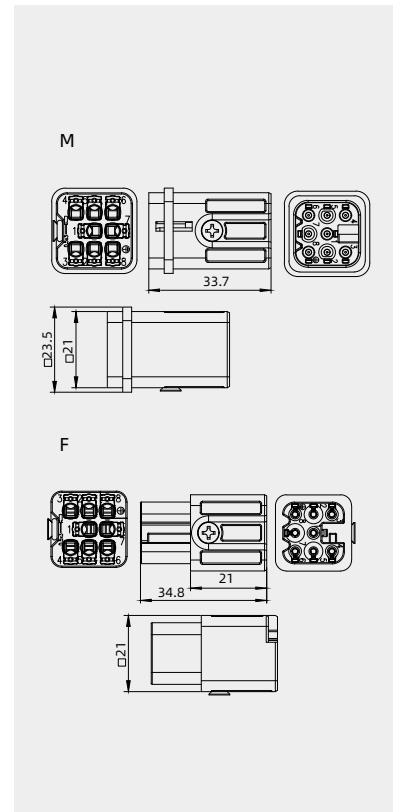

HD-025 Ultra-high density inserts

250V 10A 25+



Inserts

Hoods/Housings: size 16A,detail please find the page15-19~15-20.

Crimp terminal
order crimp contacts separately



Insert	Designation	Order No.
Male	HD-025-MC	125 025 010 0001
Female	HD-025-FC	125 025 020 0001

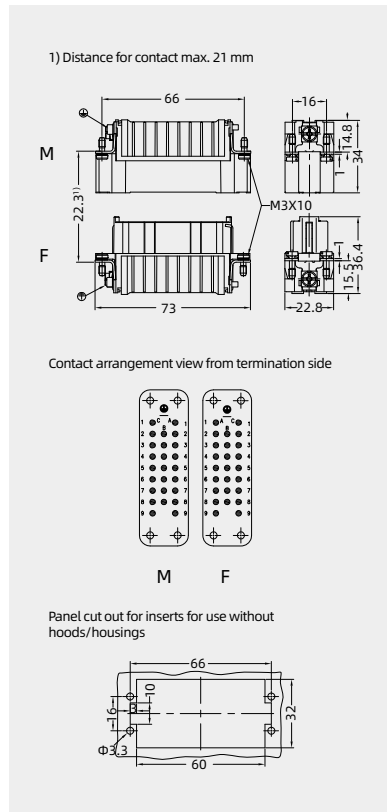

Crimp contacts

Crimp contacts 10A

Contact resistance $\leq 3m\Omega$
silver plated



gold plated



More crimp contacts 10A
see P13-02,P13-03.

Tools

Crimping tool



Contact removal tool

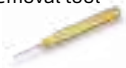

Male	Order No.	Female	Order No.
CDSM-0.25	101 017 110 0101	CDSF-0.25	101 017 120 0101
CDSM-0.37	101 017 110 0301	CDSF-0.37	101 017 120 0301
CDSM-0.50	101 017 110 0401	CDSF-0.50	101 017 120 0401
CDSM-0.75	101 017 110 0601	CDSF-0.75	101 017 120 0601
CDSM-1.0	101 017 110 0801	CDSF-1.0	101 017 120 0801
CDSM-1.5	101 017 110 0901	CDSF-1.5	101 017 120 0901
CDSM-2.5	101 017 110 1001	CDSF-2.5	101 017 120 1001

Male	Order No.	Female	Order No.
CDGM-0.25	101 017 210 0101	CDGF-0.25	101 017 220 0101
CDGM-0.37	101 017 210 0301	CDGF-0.37	101 017 220 0301
CDGM-0.50	101 017 210 0401	CDGF-0.50	101 017 220 0401
CDGM-0.75	101 017 210 0601	CDGF-0.75	101 017 220 0601
CDGM-1.0	101 017 210 0801	CDGF-1.0	101 017 220 0801
CDGM-1.5	101 017 210 0901	CDGF-1.5	101 017 220 0901
CDGM-2.5	101 017 210 1001	CDGF-2.5	101 017 220 1001

Wire gauge	Designation	Order No.
0.14-4mm ²	TL02G	198 001 001 0011

For the crimping contacts and removing contacts instructions, please find the page 06-23~06-24.

Application	Designation	Order No.
for crimp contacts 10A	TL00	198 001 000 0001

More tools detail please find the page32-03~32-06.

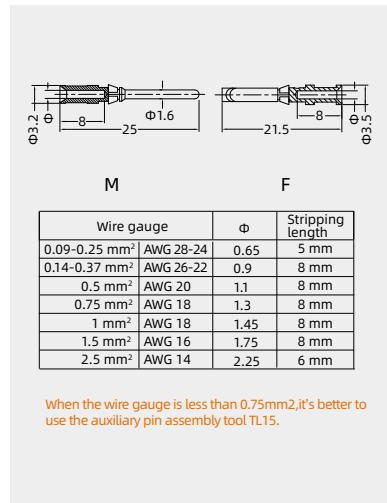

Notes: The tools for crimp terminal may influence the product quality and stability.
Please select the tools recognized by our company.

HD-050 Ultra-high density inserts

250V 10A 50+



Inserts

Hoods/Housings: size 32A, please find the details on page 15-21~15-24.

Crimp terminal

order crimp contacts separately



Insert	Designation	Order No.
Male	HD-025-MC	125 025 010 0001
	HD-025-MC(Z) ¹⁾	125 025 010 0002
Female	HD-025-FC	125 025 020 0001
	HD-025-FC(Z) ¹⁾	125 025 020 0002

1) Z represents large size digital plug.

1) Distance for contact max. 24 mm

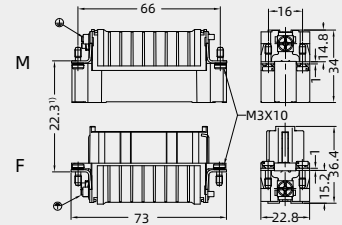

Contact arrangement view from termination side

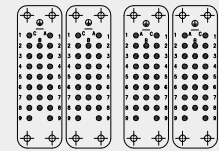

Panel cut out for inserts for use without hoods/housings

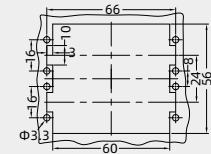

Crimp contacts

Crimp contacts 10A

Contact resistance $\leq 3m\Omega$
silver plated



gold plated



More crimp contacts 10A
see P13-02,P13-03.

Tools

Crimping tool



Contact removal tool

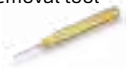

Male	Order No.	Female	Order No.
CDSM-0.25	101 017 110 0101	CDSF-0.25	101 017 120 0101
CDSM-0.37	101 017 110 0301	CDSF-0.37	101 017 120 0301
CDSM-0.50	101 017 110 0401	CDSF-0.50	101 017 120 0401
CDSM-0.75	101 017 110 0601	CDSF-0.75	101 017 120 0601
CDSM-1.0	101 017 110 0801	CDSF-1.0	101 017 120 0801
CDSM-1.5	101 017 110 0901	CDSF-1.5	101 017 120 0901
CDSM-2.5	101 017 110 1001	CDSF-2.5	101 017 120 1001

Male	Order No.	Female	Order No.
CDGM-0.25	101 017 210 0101	CDGF-0.25	101 017 220 0101
CDGM-0.37	101 017 210 0301	CDGF-0.37	101 017 220 0301
CDGM-0.50	101 017 210 0401	CDGF-0.50	101 017 220 0401
CDGM-0.75	101 017 210 0601	CDGF-0.75	101 017 220 0601
CDGM-1.0	101 017 210 0801	CDGF-1.0	101 017 220 0801
CDGM-1.5	101 017 210 0901	CDGF-1.5	101 017 220 0901
CDGM-2.5	101 017 210 1001	CDGF-2.5	101 017 220 1001

Wire gauge	Designation	Order No.
0.14-4mm ²	TL02G	198 001 001 0011

For the crimping contacts and removing contacts instructions, please find the page 06-23-06-24.

Application	Designation	Order No.
for crimp contacts 10A	TL00	198 001 000 0001

More tools detail please find the page 32-03~32-06.

Notes: The tools for crimp terminal may influence the product quality and stability.
Please select the tools recognized by our company.

Wire gauge	ϕ	Stripping length
0.09-0.25 mm ²	AWG 28-24	0.65
0.14-0.37 mm ²	AWG 26-22	0.9
0.5 mm ²	AWG 20	1.1
0.75 mm ²	AWG 18	1.3
1 mm ²	AWG 18	1.45
1.5 mm ²	AWG 16	1.75
2.5 mm ²	AWG 14	2.25

When the wire gauge is less than 0.75mm², it's better to use the auxiliary pin assembly tool TL15.

HD-040 Ultra-high density inserts

250V 10A 40+

CE ENEC

Inserts



Hoods/Housings: size 16B, please find the details on page 15-70~15-1071.

Crimp terminal

order crimp contacts separately



The insert only matches 10A stamped contacts.

Insert	Designation	Order No.
Male	HD-040-MC/P	125 040 010 0021
	HD-040-FC/P	125 040 020 0021

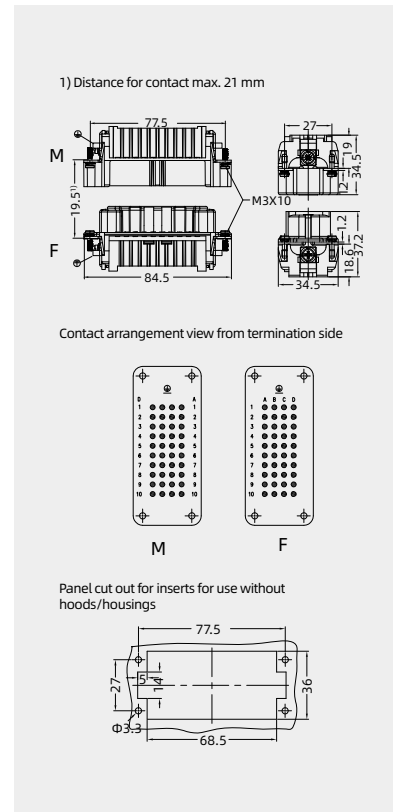

Crimp contacts

Stamped contacts 10A

silver plated



coil stock



Wire gauge	contacts	Designation	Order No.
0.5-1.5mm ²	male	CDSM-1.5P	101 017 110 0905
	female	CDSF-1.5P	101 017 120 0905
1.5-2.5mm ²	male	CDSM-2.5P	101 017 110 1005
	female	CDSF-2.5P	101 017 120 1005

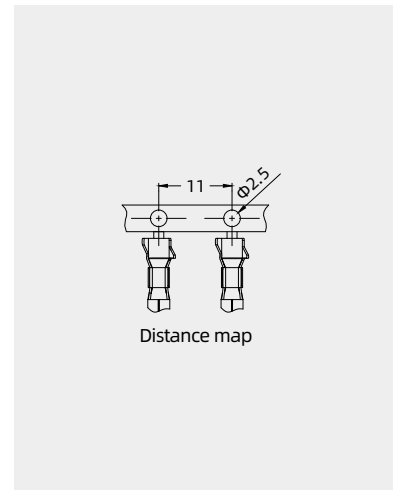

Tools

Crimping tool



Contact removal tool



Wire gauge	Designation	Order No.
0.5-2.5mm ²	TL14	198 001 001 0022

Application	Designation	Order No.
10A male contacts	TL00	198 001 000 0001
10A female contacts	TL13	198 001 000 0025

更多工具详情请参见第 32-03~32-06 页

Notes: The tools for crimp terminal may influence the product quality and stability. Please select the tools recognized by our company.

HD-064 Ultra-high density inserts

250V 10A 64+ 

EAC

Inserts



Hoods/Housings: size 24B, please find the details on page 15-108~15-150.

Crimp terminal

order crimp contacts separately



Insert	Designation	Order No.
Male	HD-064-MC	125 064 010 0001
Female	HD-064-FC	125 064 020 0001

Wrap terminal¹⁾ 1x1 mm



Insert	Designation	Order No.
Male	HD-064-MTHT	125 064 014 0001
Female	HD-064-FTHT	125 064 024 0001

1) See P00-14 for the structural characteristics of wrap terminal.

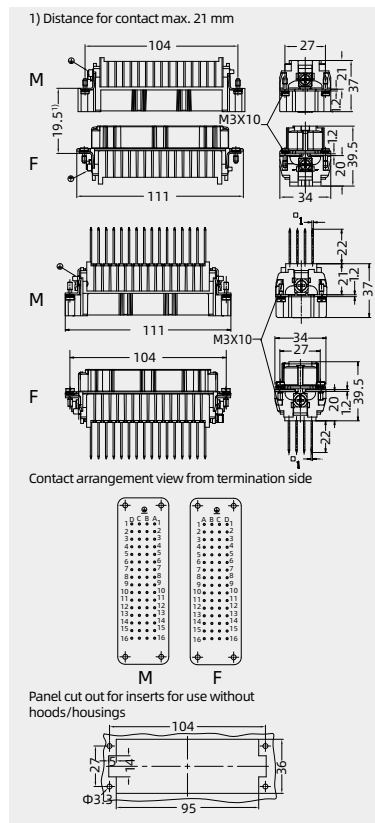

Crimp contacts

Crimp contacts 10A

Contact resistance $\leq 3m\Omega$
silver plated



Male	Order No.	Female	Order No.
CDSM-0.25	101 017 110 0101	CDSF-0.25	101 017 120 0101
CDSM-0.37	101 017 110 0301	CDSF-0.37	101 017 120 0301
CDSM-0.50	101 017 110 0401	CDSF-0.50	101 017 120 0401
CDSM-0.75	101 017 110 0601	CDSF-0.75	101 017 120 0601
CDSM-1.0	101 017 110 0801	CDSF-1.0	101 017 120 0801
CDSM-1.5	101 017 110 0901	CDSF-1.5	101 017 120 0901
CDSM-2.5	101 017 110 1001	CDSF-2.5	101 017 120 1001

gold plated



Male	Order No.	Female	Order No.
CDGM-0.25	101 017 210 0101	CDGF-0.25	101 017 220 0101
CDGM-0.37	101 017 210 0301	CDGF-0.37	101 017 220 0301
CDGM-0.50	101 017 210 0401	CDGF-0.50	101 017 220 0401
CDGM-0.75	101 017 210 0601	CDGF-0.75	101 017 220 0601
CDGM-1.0	101 017 210 0801	CDGF-1.0	101 017 220 0801
CDGM-1.5	101 017 210 0901	CDGF-1.5	101 017 220 0901
CDGM-2.5	101 017 210 1001	CDGF-2.5	101 017 220 1001

More crimp contacts 10A see P13-02,P13-03.

Tools

Crimping tool



Contact removal tool

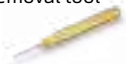

Wire gauge	Designation	Order No.
0.14-4mm ²	TL02G	198 001 001 0011

For the crimping contacts and removing contacts instructions, please find the page 06-23~06-24.

Application	Designation	Order No.
for crimp contacts 10A	TL00	198 001 000 0001

More tools detail please find the page 32-03~32-06.

Notes: The tools for crimp terminal may influence the product quality and stability. Please select the tools recognized by our company.

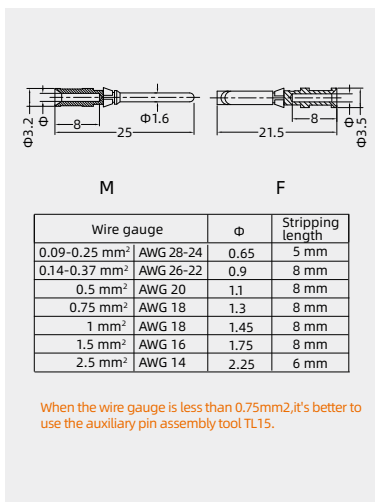

HD-064 Ultra-high density inserts

250V 10A 64+

Inserts

Hoods/Housings: size 24B, please find the details on page 15-108-15-150.

Crimp terminal

order crimp contacts separately



The insert only matches 10A stamped contacts.

Insert	Designation	Order No.
Male	HD-064-MC/P	125 064 010 0021
	HD-064-FC/P	125 064 020 0021

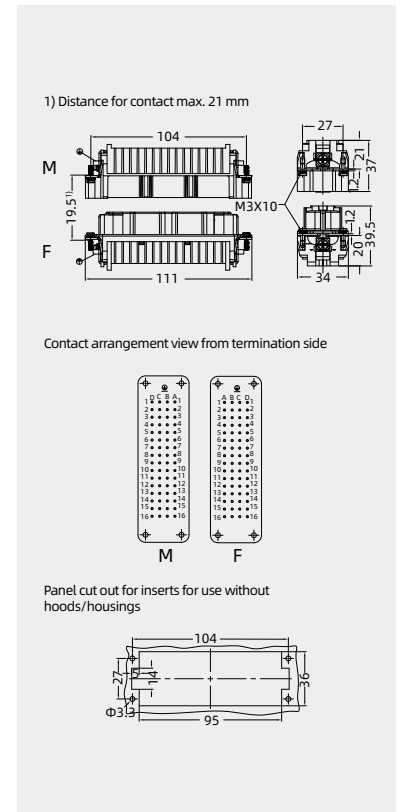

Crimp contacts

Stamped contacts 10A

silver plated



coil stock



Wire gauge	contacts	Designation	Order No.
0.5-1.5mm ²	male	CDSM-1.5P	101 017 110 0905
	female	CDSF-1.5P	101 017 120 0905
1.5-2.5mm ²	male	CDSM-2.5P	101 017 110 1005
	female	CDSF-2.5P	101 017 120 1005

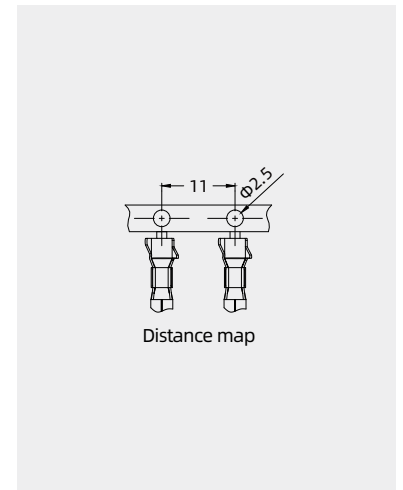

Tools

Crimping tool



Contact removal tool



Wire gauge	Designation	Order No.
0.5-2.5mm ²	TL14	198 001 001 0022

Application	Designation	Order No.
10A male contacts	TL00	198 001 000 0001
10A female contacts	TL13	198 001 000 0025

更多工具详情请参见第 32-03~32-06 页

Notes: The tools for crimp terminal may influence the product quality and stability. Please select the tools recognized by our company.

HD-080 Ultra-high density inserts

250V 10A 80+



Inserts

Hoods/Housings: size 32B, please find the details on page 15-151~15-159.

Crimp terminal

order crimp contacts separately



Insert	Designation	Order No.
Male	HD-040-MC	125 040 010 0001
	HD-040-MC(Z) ¹⁾	125 040 010 0002
Female	HD-040-FC	125 040 020 0001
	HD-040-FC(Z) ¹⁾	125 040 020 0002

1) Z represents large size digital plug.

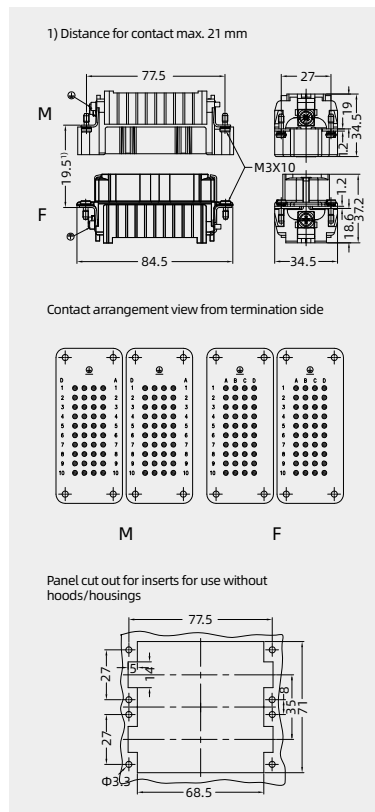

Crimp contacts

Crimp contacts 10A

Contact resistance $\leq 3m\Omega$
silver plated



gold plated



More crimp contacts 10A
see P13-02,P13-03.

Tools

Crimping tool



Contact removal tool

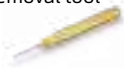

Male	Order No.	Female	Order No.
CDSM-0.25	101 017 110 0101	CDSF-0.25	101 017 120 0101
CDSM-0.37	101 017 110 0301	CDSF-0.37	101 017 120 0301
CDSM-0.50	101 017 110 0401	CDSF-0.50	101 017 120 0401
CDSM-0.75	101 017 110 0601	CDSF-0.75	101 017 120 0601
CDSM-1.0	101 017 110 0801	CDSF-1.0	101 017 120 0801
CDSM-1.5	101 017 110 0901	CDSF-1.5	101 017 120 0901
CDSM-2.5	101 017 110 1001	CDSF-2.5	101 017 120 1001
CDGM-0.25	101 017 210 0101	CDGF-0.25	101 017 220 0101
CDGM-0.37	101 017 210 0301	CDGF-0.37	101 017 220 0301
CDGM-0.50	101 017 210 0401	CDGF-0.50	101 017 220 0401
CDGM-0.75	101 017 210 0601	CDGF-0.75	101 017 220 0601
CDGM-1.0	101 017 210 0801	CDGF-1.0	101 017 220 0801
CDGM-1.5	101 017 210 0901	CDGF-1.5	101 017 220 0901
CDGM-2.5	101 017 210 1001	CDGF-2.5	101 017 220 1001

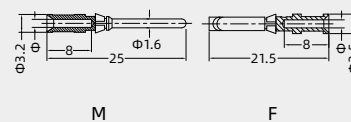

Wire gauge	ϕ	Stripping length
0.09-0.25 mm ²	AWG 28-24	0.65
0.14-0.37 mm ²	AWG 26-22	0.9
0.5 mm ²	AWG 20	1.1
0.75 mm ²	AWG 18	1.3
1 mm ²	AWG 18	1.45
1.5 mm ²	AWG 16	1.75
2.5 mm ²	AWG 14	2.25

When the wire gauge is less than 0.75mm², it's better to use the auxiliary pin assembly tool TL15.

Wire gauge	Designation	Order No.
0.14-4mm ²	TL02G	198 001 001 0011
For the crimping contacts and removing contacts instructions, please find the page 06-23-06-24.		
Application	Designation	Order No.
for crimp contacts 10A	TL00	198 001 000 0001
More tools detail please find the page 32-03~32-06.		

Notes: The tools for crimp terminal may influence the product quality and stability.
Please select the tools recognized by our company.

HD-128 Ultra-high density inserts

250V 10A 128+



Inserts

Hoods/Housings: size 48B, please find the details on page 15-160~15-162.

Crimp terminal
order crimp contacts separately



Insert	Designation	Order No.
Male	HD-064-MC	125 064 010 0001
	HD-064-MC(Z) ¹⁾	125 064 010 0002
Female	HD-064-FC	125 064 020 0001
	HD-064-FC(Z) ¹⁾	125 064 020 0002

¹⁾ Z represents large size digital plug.

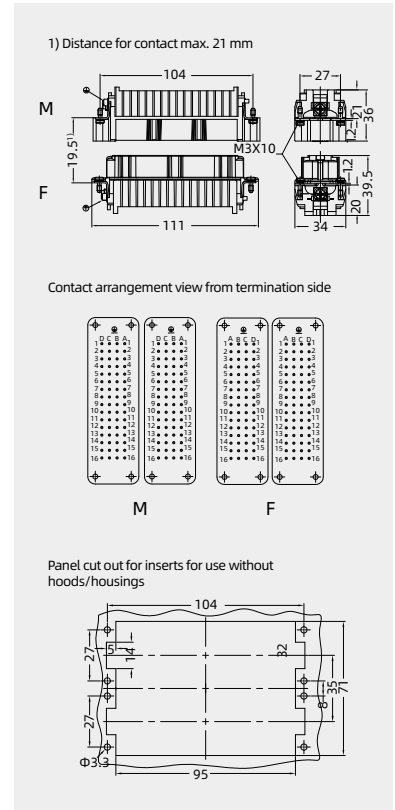

Crimp contacts

Crimp contacts 10A

Contact resistance $\leq 3m\Omega$
silver plated



gold plated



More crimp contacts 10A
see P13-02,P13-03.

Tools

Crimping tool



Contact removal tool

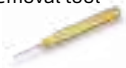

Male	Order No.	Female	Order No.
CDSM-0.25	101 017 110 0101	CDSF-0.25	101 017 120 0101
CDSM-0.37	101 017 110 0301	CDSF-0.37	101 017 120 0301
CDSM-0.50	101 017 110 0401	CDSF-0.50	101 017 120 0401
CDSM-0.75	101 017 110 0601	CDSF-0.75	101 017 120 0601
CDSM-1.0	101 017 110 0801	CDSF-1.0	101 017 120 0801
CDSM-1.5	101 017 110 0901	CDSF-1.5	101 017 120 0901
CDSM-2.5	101 017 110 1001	CDSF-2.5	101 017 120 1001
CDGM-0.25	101 017 210 0101	CDGF-0.25	101 017 220 0101
CDGM-0.37	101 017 210 0301	CDGF-0.37	101 017 220 0301
CDGM-0.50	101 017 210 0401	CDGF-0.50	101 017 220 0401
CDGM-0.75	101 017 210 0601	CDGF-0.75	101 017 220 0601
CDGM-1.0	101 017 210 0801	CDGF-1.0	101 017 220 0801
CDGM-1.5	101 017 210 0901	CDGF-1.5	101 017 220 0901
CDGM-2.5	101 017 210 1001	CDGF-2.5	101 017 220 1001

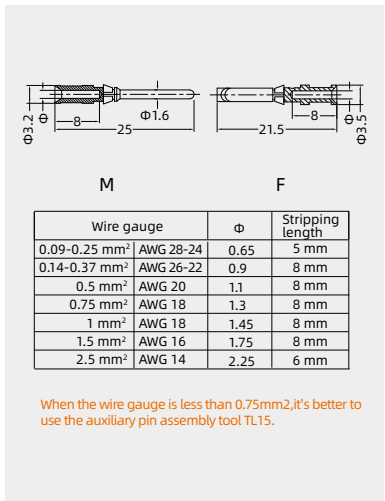

Wire gauge	Designation	Order No.
0.14-4mm ²	TL02G	198 001 001 0011

For the crimping contacts and removing contacts instructions, please find the page 06-23~06-24.

Application	Designation	Order No.
for crimp contacts 10A	TL00	198 001 000 0001

More tools detail please find the page 32-03~32-06.

Notes: The tools for crimp terminal may influence the product quality and stability.
Please select the tools recognized by our company.

HDD-024 Ultra-high density inserts

250V 10A 24+



Inserts

Hoods/Housings: size 6B, please find the details on page 15-25~15-38.

Crimp terminal

order crimp contacts separately

Insert	Designation	Order No.
Male	HDD-024-MC ¹⁾	126 024 010 0001
Female	HDD-024-FC ¹⁾	126 024 020 0001



1). Can match PCB adapter, see page 14-02~14-03.

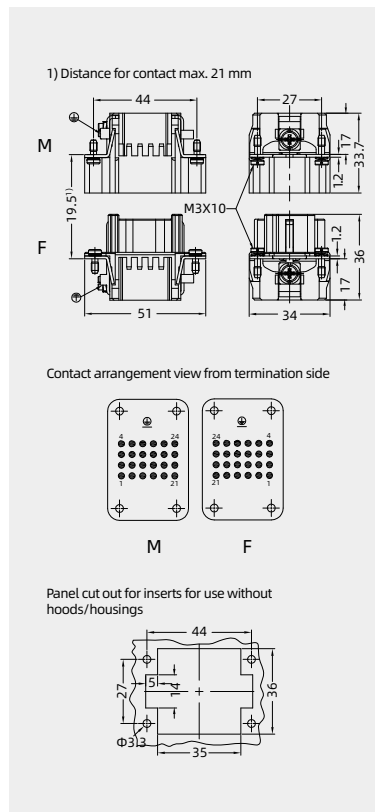

Crimp contacts

Crimp contacts 10A

Contact resistance $\leq 3m\Omega$
silver plated



gold plated



More crimp contacts 10A
see P13-02, P13-03.

Male	Order No.	Female	Order No.
CDSM-0.25	101 017 110 0101	CDSF-0.25	101 017 120 0101
CDSM-0.37	101 017 110 0301	CDSF-0.37	101 017 120 0301
CDSM-0.50	101 017 110 0401	CDSF-0.50	101 017 120 0401
CDSM-0.75	101 017 110 0601	CDSF-0.75	101 017 120 0601
CDSM-1.0	101 017 110 0801	CDSF-1.0	101 017 120 0801
CDSM-1.5	101 017 110 0901	CDSF-1.5	101 017 120 0901
CDSM-2.5	101 017 110 1001	CDSF-2.5	101 017 120 1001

Male	Order No.	Female	Order No.
CDGM-0.25	101 017 210 0101	CDGF-0.25	101 017 220 0101
CDGM-0.37	101 017 210 0301	CDGF-0.37	101 017 220 0301
CDGM-0.50	101 017 210 0401	CDGF-0.50	101 017 220 0401
CDGM-0.75	101 017 210 0601	CDGF-0.75	101 017 220 0601
CDGM-1.0	101 017 210 0801	CDGF-1.0	101 017 220 0801
CDGM-1.5	101 017 210 0901	CDGF-1.5	101 017 220 0901
CDGM-2.5	101 017 210 1001	CDGF-2.5	101 017 220 1001

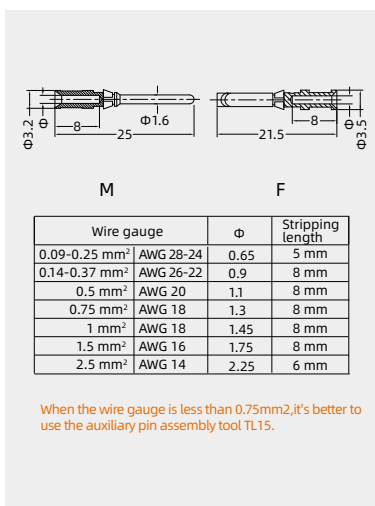

Tools

Crimping tool



Contact removal tool

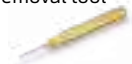

Wire gauge	Designation	Order No.
0.14-4mm ²	TL02G	198 001 001 0011

For the crimping contacts and removing contacts instructions, please find the page 06-23~06-24.

Application	Designation	Order No.
for crimp contacts 10A	TL00	198 001 000 0001

More tools detail please find the page 32-03~32-06.

Notes: The tools for crimp terminal may influence the product quality and stability. Please select the tools recognized by our company.

HDD-042 Ultra-high density inserts

250V 10A 42+



Inserts

Hoods/Housings: size **10B**, please find the details on page 15-39~15-69.

Crimp terminal

order crimp contacts separately



Insert	Designation	Order No.
Male	HDD-042-MC ¹⁾	126 042 010 0001
Female	HDD-042-FC ¹⁾	126 042 020 0001

¹⁾Can match PCB adapter,see page 14-02~14-03.

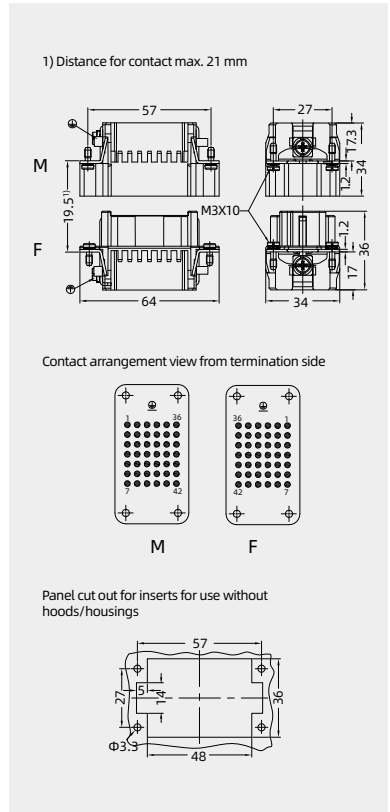

Crimp contacts

Crimp contacts 10A

Contact resistance $\leq 3m\Omega$
silver plated



gold plated



More crimp contacts 10A
see P13-02,P13-03.

Tools

Crimping tool



Contact removal tool

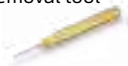

Male	Order No.	Female	Order No.
CDSM-0.25	101 017 110 0101	CDSF-0.25	101 017 120 0101
CDSM-0.37	101 017 110 0301	CDSF-0.37	101 017 120 0301
CDSM-0.50	101 017 110 0401	CDSF-0.50	101 017 120 0401
CDSM-0.75	101 017 110 0601	CDSF-0.75	101 017 120 0601
CDSM-1.0	101 017 110 0801	CDSF-1.0	101 017 120 0801
CDSM-1.5	101 017 110 0901	CDSF-1.5	101 017 120 0901
CDSM-2.5	101 017 110 1001	CDSF-2.5	101 017 120 1001

Male	Order No.	Female	Order No.
CDGM-0.25	101 017 210 0101	CDGF-0.25	101 017 220 0101
CDGM-0.37	101 017 210 0301	CDGF-0.37	101 017 220 0301
CDGM-0.50	101 017 210 0401	CDGF-0.50	101 017 220 0401
CDGM-0.75	101 017 210 0601	CDGF-0.75	101 017 220 0601
CDGM-1.0	101 017 210 0801	CDGF-1.0	101 017 220 0801
CDGM-1.5	101 017 210 0901	CDGF-1.5	101 017 220 0901
CDGM-2.5	101 017 210 1001	CDGF-2.5	101 017 220 1001

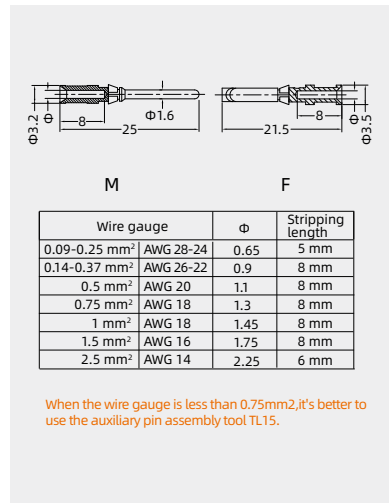

Wire gauge	Designation	Order No.
0.14-4mm ²	TL02G	198 001 001 0011

For the crimping contacts and removing contacts instructions, please find the page 06-23~06-24.

Application	Designation	Order No.
for crimp contacts 10A	TL00	198 001 000 0001

More tools detail please find the page 32-03~32-06.

Notes: The tools for crimp terminal may influence the product quality and stability. Please select the tools recognized by our company.

HDD-072 Ultra-high density inserts

250V 10A 72+



Inserts

Hoods/Housings: size 16B, please find the details on page 15-70~15-1071.

Crimp terminal

order crimp contacts separately



Insert	Designation	Order No.
Male	HDD-072-MC ¹⁾	126 072 010 0001
Female	HDD-072-FC ¹⁾	126 072 020 0001

1). Can match PCB adapter, see page 14-02~14-03.

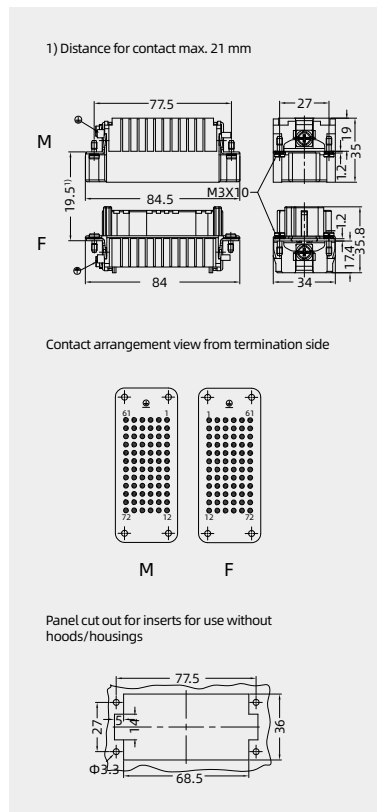

Crimp contacts

Crimp contacts 10A

Contact resistance $\leq 3m\Omega$
silver plated



gold plated



More crimp contacts 10A
see P13-02, P13-03.

Male	Order No.	Female	Order No.
CDSM-0.25	101 017 110 0101	CDSF-0.25	101 017 120 0101
CDSM-0.37	101 017 110 0301	CDSF-0.37	101 017 120 0301
CDSM-0.50	101 017 110 0401	CDSF-0.50	101 017 120 0401
CDSM-0.75	101 017 110 0601	CDSF-0.75	101 017 120 0601
CDSM-1.0	101 017 110 0801	CDSF-1.0	101 017 120 0801
CDSM-1.5	101 017 110 0901	CDSF-1.5	101 017 120 0901
CDSM-2.5	101 017 110 1001	CDSF-2.5	101 017 120 1001
CDGM-0.25	101 017 210 0101	CDGF-0.25	101 017 220 0101
CDGM-0.37	101 017 210 0301	CDGF-0.37	101 017 220 0301
CDGM-0.50	101 017 210 0401	CDGF-0.50	101 017 220 0401
CDGM-0.75	101 017 210 0601	CDGF-0.75	101 017 220 0601
CDGM-1.0	101 017 210 0801	CDGF-1.0	101 017 220 0801
CDGM-1.5	101 017 210 0901	CDGF-1.5	101 017 220 0901
CDGM-2.5	101 017 210 1001	CDGF-2.5	101 017 220 1001

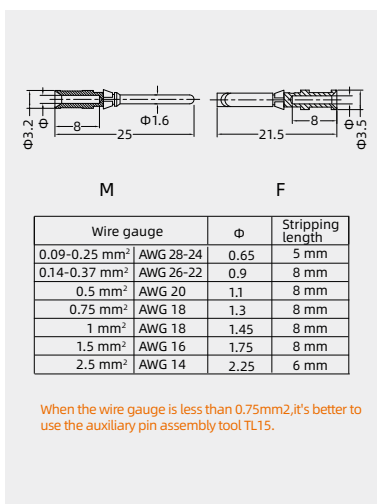

Tools

Crimping tool



Contact removal tool

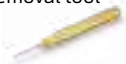

Wire gauge	Designation	Order No.
0.14-4mm ²	TL02G	198 001 001 0011

For the crimping contacts and removing contacts instructions, please find the page 06-23~06-24.

Application	Designation	Order No.
for crimp contacts 10A	TL00	198 001 000 0001

More tools detail please find the page 32-03~32-06.

Notes: The tools for crimp terminal may influence the product quality and stability.
Please select the tools recognized by our company.

HDD-108 Ultra-high density inserts

250V 10A 108+



Inserts

Hoods/Housings: size 24B, please find the details on page 15-108~15-150.

Crimp terminal

order crimp contacts separately



Insert	Designation	Order No.
Male	HDD-108-MC ¹⁾	126 108 010 0001
Female	HDD-108-FC ¹⁾	126 108 020 0001

¹⁾Can match PCB adapter,see page 14-02~14-03.

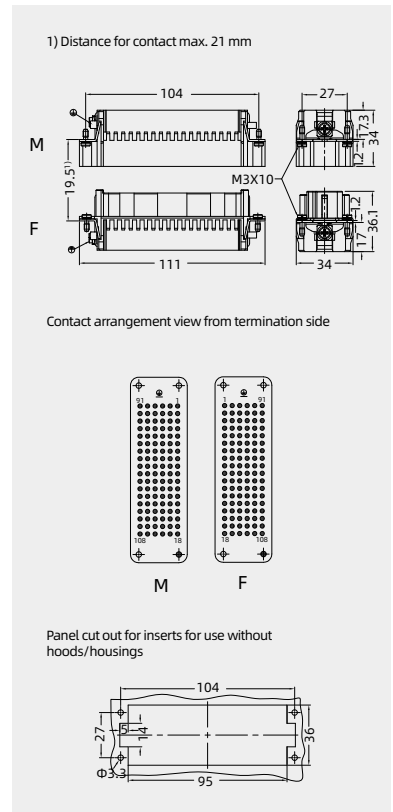

Crimp contacts

Crimp contacts 10A

Contact resistance $\leq 3m\Omega$
silver plated



gold plated



More crimp contacts 10A
see P13-02,P13-03.

Tools

Crimping tool



Contact removal tool

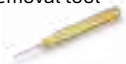

Male	Order No.	Female	Order No.
CDSM-0.25	101 017 110 0101	CDSF-0.25	101 017 120 0101
CDSM-0.37	101 017 110 0301	CDSF-0.37	101 017 120 0301
CDSM-0.50	101 017 110 0401	CDSF-0.50	101 017 120 0401
CDSM-0.75	101 017 110 0601	CDSF-0.75	101 017 120 0601
CDSM-1.0	101 017 110 0801	CDSF-1.0	101 017 120 0801
CDSM-1.5	101 017 110 0901	CDSF-1.5	101 017 120 0901
CDSM-2.5	101 017 110 1001	CDSF-2.5	101 017 120 1001

Male	Order No.	Female	Order No.
CDGM-0.25	101 017 210 0101	CDGF-0.25	101 017 220 0101
CDGM-0.37	101 017 210 0301	CDGF-0.37	101 017 220 0301
CDGM-0.50	101 017 210 0401	CDGF-0.50	101 017 220 0401
CDGM-0.75	101 017 210 0601	CDGF-0.75	101 017 220 0601
CDGM-1.0	101 017 210 0801	CDGF-1.0	101 017 220 0801
CDGM-1.5	101 017 210 0901	CDGF-1.5	101 017 220 0901
CDGM-2.5	101 017 210 1001	CDGF-2.5	101 017 220 1001

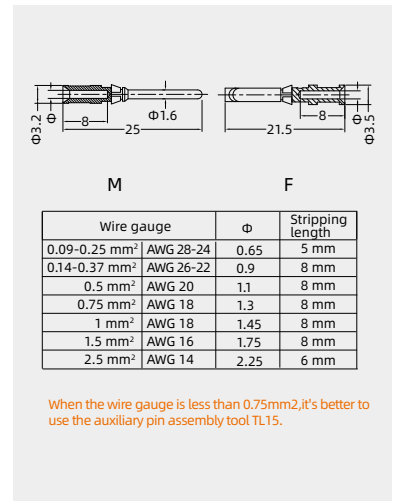

Notes: The tools for crimp terminal may influence the product quality and stability.
Please select the tools recognized by our company.

HDD-108 Ultra-high density inserts

200V 7.5A 108+ 

Inserts

Hoods/Housings: This kind of insert only match with W24B-RBK housing

Soldered PCB connection

Insert	Designation	Order No.
Male	HDD-108-MSHT	126 108 013 1001

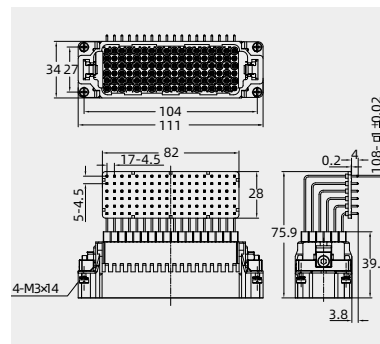

Bulkhead Mounted Housings

(Assemble the inserts in reverse direction)

Thread	Designation	Order No.
---	W24B-RBK-2L/SC	111 124 341 1003



Please refer to page 15-02 for choosing proper model of lock.

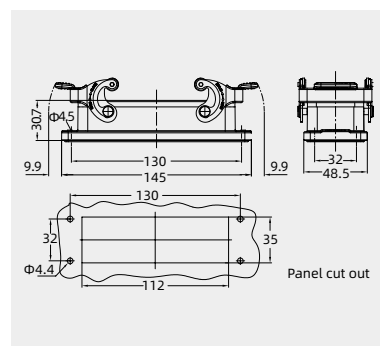

Product features

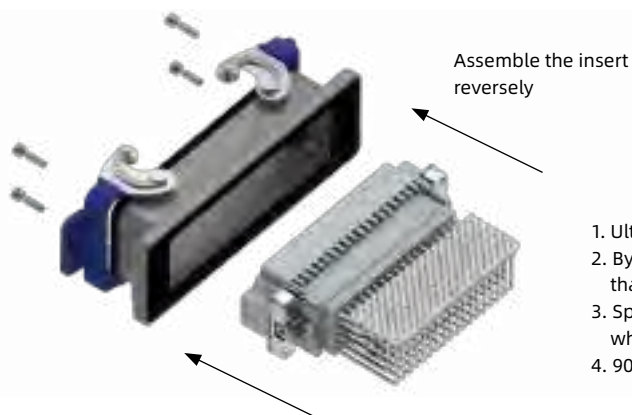

1. Ultra-high density insert: 108pin.
2. By welding manner, the assembly efficiency is much higher than the traditional wiring methods.
3. Specially designed housing makes sure that the insert can be assembled in reverse, which is convenient for installation and maintenance in practical application.
4. 90 degree pcb soldering termination design, quick and convenient.

HDD-216 Ultra-high density inserts

250V 10A 216+



Inserts

Hoods/Housings: size 48B, please find the details on page 15-160~15-162.

Crimp terminal

order crimp contacts separately



Insert	Designation	Order No.
Male	HDD-108-MC ¹⁾	126 108 010 0001
	HDD-108-MC(109-216) ¹⁾	126 108 010 0002
Female	HDD-108-FC ¹⁾	126 108 020 0001
	HDD-108-FC(109-216) ¹⁾	126 108 020 0002

1).Can match PCB adapter,see page 14-02~14-03.

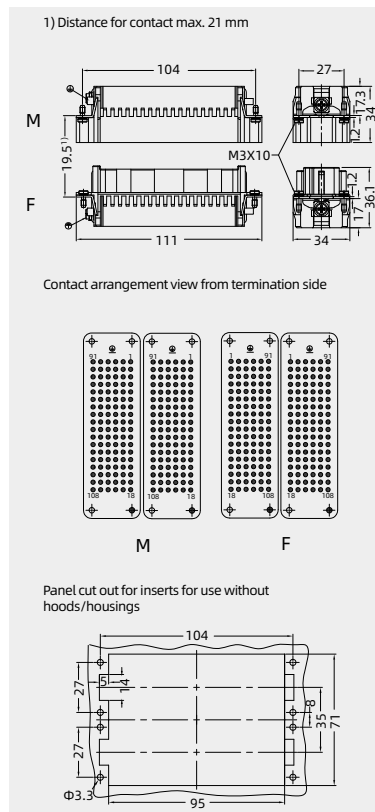

Crimp contacts

Crimp contacts 10A

Contact resistance $\leq 3m\Omega$
silver plated



gold plated



Male	Order No.	Female	Order No.
CDSM-0.25	101 017 110 0101	CDSF-0.25	101 017 120 0101
CDSM-0.37	101 017 110 0301	CDSF-0.37	101 017 120 0301
CDSM-0.50	101 017 110 0401	CDSF-0.50	101 017 120 0401
CDSM-0.75	101 017 110 0601	CDSF-0.75	101 017 120 0601
CDSM-1.0	101 017 110 0801	CDSF-1.0	101 017 120 0801
CDSM-1.5	101 017 110 0901	CDSF-1.5	101 017 120 0901
CDSM-2.5	101 017 110 1001	CDSF-2.5	101 017 120 1001

Male	Order No.	Female	Order No.
CDGM-0.25	101 017 210 0101	CDGF-0.25	101 017 220 0101
CDGM-0.37	101 017 210 0301	CDGF-0.37	101 017 220 0301
CDGM-0.50	101 017 210 0401	CDGF-0.50	101 017 220 0401
CDGM-0.75	101 017 210 0601	CDGF-0.75	101 017 220 0601
CDGM-1.0	101 017 210 0801	CDGF-1.0	101 017 220 0801
CDGM-1.5	101 017 210 0901	CDGF-1.5	101 017 220 0901
CDGM-2.5	101 017 210 1001	CDGF-2.5	101 017 220 1001

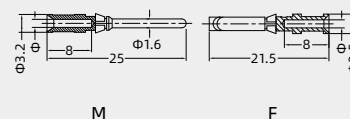

More crimp contacts 10A
see P13-02,P13-03.

Tools

Crimping tool



Contact removal tool

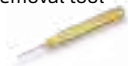

Wire gauge	Designation	Order No.
0.14-4mm ²	TL02G	198 001 001 0011

For the crimping contacts and removing contacts instructions, please find the page 06-23-06-24.

Application	Designation	Order No.
for crimp contacts 10A	TL00	198 001 000 0001

More tools detail please find the page 32-03~32-06.

Wire gauge	ϕ	Stripping length
0.09-0.25 mm ²	AWG 28-24	0.65 5 mm
0.14-0.37 mm ²	AWG 26-22	0.9 8 mm
0.5 mm ²	AWG 20	1.1 8 mm
0.75 mm ²	AWG 18	1.3 8 mm
1 mm ²	AWG 18	1.45 8 mm
1.5 mm ²	AWG 16	1.75 8 mm
2.5 mm ²	AWG 14	2.25 6 mm

When the wire gauge is less than 0.75mm²,it's better to use the auxiliary pin assembly tool TL15.

Notes: The tools for crimp terminal may influence the product quality and stability.
Please select the tools recognized by our company.

Assembly and removal instructions of D Crimp contact

Assembly

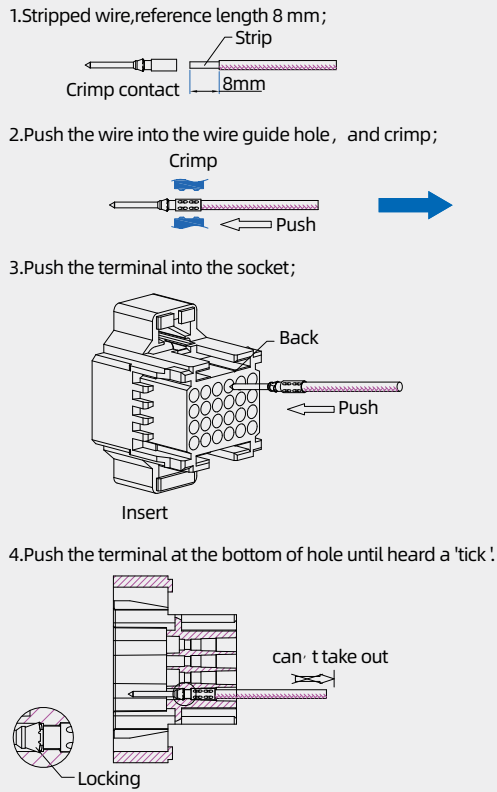

Crimp contact

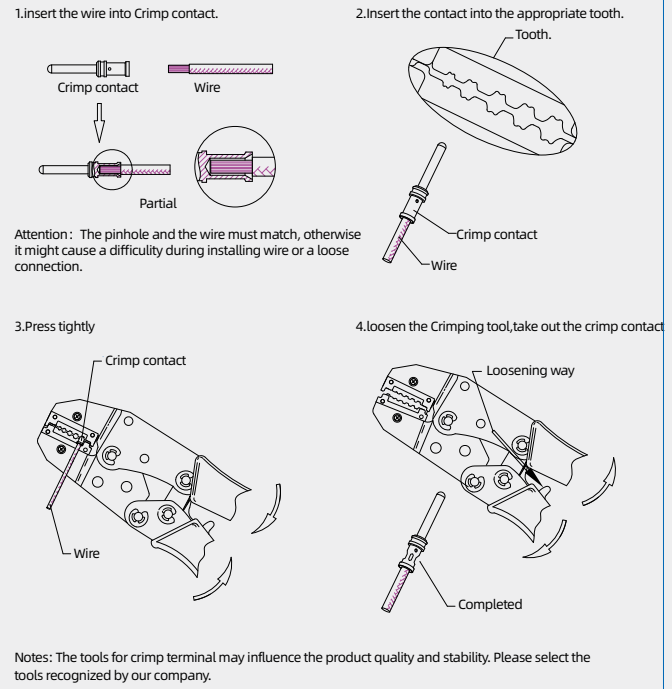

Removal

1. Pull the tool into the hole of terminal as shown in the figure.

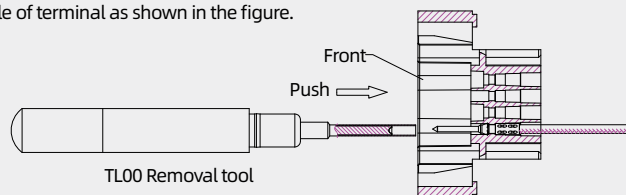

2. Push the tool at the bottom of hole, then spring the terminal.

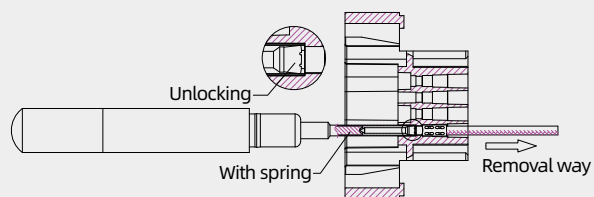

3. Removal the terminal.

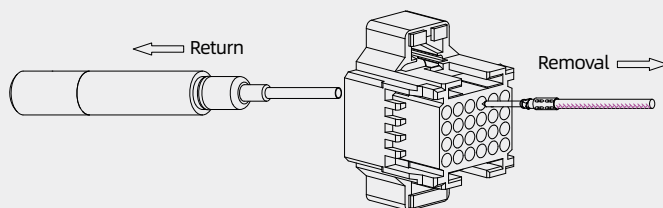

HSB SERIES

35A heavy-current connector



HSB SERIES Heavy-current inserts

Technical characteristics

Technical characteristics	DIN EN 60 664 DIN EN 61 984
Approvals	
Inserts	
Number of contacts	6,12+PE
Electrical data acc. to EN 61 984	
-Rated current	35A
-Rated voltage conductor - ground	400V
-Rated voltage conductor - conductor	690V
-Rated impulse voltage	6kV
-Pollution degree	3
-or	35A 500V 6kV 3
Rated voltage acc. to UL	600V
Insulation resistance	$\geq 10^{10}\Omega$
Material	polycarbonate
Limiting temperatures	-40°C ... +125°C
Flammability acc. to UL 94	V0
Mechanical working life(mating cycles)	≥ 500
Contacts	
Material	copper alloy
Surface	hard-silver plated
Contact resistance	$\leq 1m\Omega$
Screw terminal	
- Wire gauge	1.5-6mm ²
- AWG	10
- Tightening torque	1.2Nm

Current carrying capacity

The current carrying is limited by maximum temperature of materials for inserts and contacts including terminals

Control and test procedures according to DIN EN 60512-5

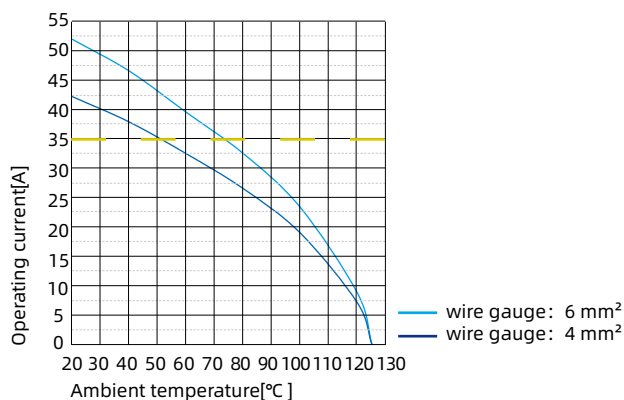

HSB-006 Heavy-current inserts

400/690V 35A 6+⊕



Inserts

Hoods/Housings: size 16B, please find the details on page 15-70~15-1071.

Screw terminal



Insert	Designation	Order No.
Male	HSB-006-M	127 006 011 0001
Female	HSB-006-F	127 006 021 0001

1) Distance for contact max. 21 mm

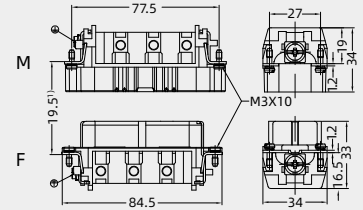

Contact arrangement view from termination side

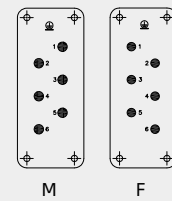

Panel cut out for inserts for use without hoods/housings

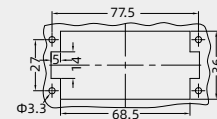

HSB-012 Heavy-current inserts

400/690V 35A 12+ 



Inserts

Hoods/Housings: size **32B**, please find the details on page 15-151~15-159.

Screw terminal



Insert	Designation	Order No.
Male	HSB-006-M	127 006 011 0001
	HSB-006-M(7-12)	127 006 011 0002
Female	HSB-006-F	127 006 021 0001
	HSB-006-F(7-12)	127 006 021 0002

1) Distance for contact max. 21 mm

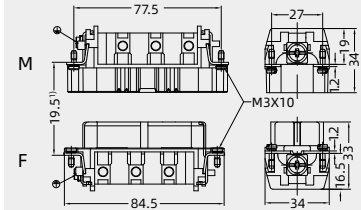

Contact arrangement view from termination side

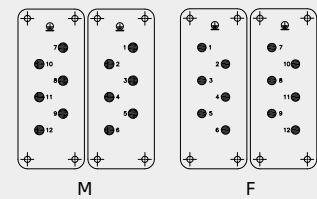

Panel cut out for inserts for use without hoods/housings

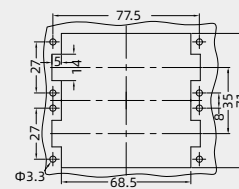

HSB-004/2 Heavy-current inserts(Quick-in)

Technical characteristics

Technical characteristics	DIN EN 60 664 DIN EN 61 984
---------------------------	--------------------------------

Approvals

Inserts

Number of contacts	4/2+PE
--------------------	--------

Electrical data acc. to EN 61 984

-Rated current	40A/16A
-Rated voltage conductor - ground	690V/500V
-Rated impulse voltage	6kV/6kV
-Pollution degree	3
-Insulation resistance	$\geq 10^{10}\Omega$
Material	polycarbonate
Colour	RAL 7032(light grey)
Limiting temperatures	-40°C ...+125°C
Flammability acc. to UL 94	V0
Mating cycles	≥ 500

Contacts

Terminal	spring terminal(Quick-in)
Material	copper alloy
Surface	hard-silver plated
Contact resistance	$\leq 3m\Omega$
Wire gauge	0.5-2.5mm ² (20-14AWG) 0.5-6mm ² (20-10AWG)
Stripping length	12.5mm/12mm

HSB-004/2 Heavy-current inserts(Quick-in)

690/500V 40/16A 4/2+ 

Inserts

Hoods/Housings: size 16B, please find the details on page 15-70~15-1071.

Spring terminal(Quick-in)



Insert	Designation	Order No.
Male	HSB-004/2-MQ	127 006 001 0001
Female	HSB-004/2-FQ	127 006 002 0001

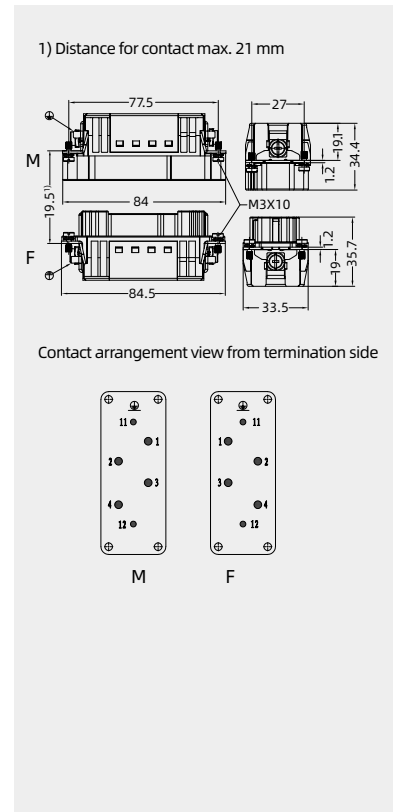



HSB

HK SERIES

Combination connector



HK-008/24 Combination inserts



Technical characteristics

Specifications	DIN EN 60 664 DIN EN 61 984
Approvals	UL VDE CE ENEC CCC
Inserts	
Number of contacts	8/24+PE
Electrical data acc. to EN 61 984	
Power area	
-Rated current	16A
-Rated voltage conductor	400V
-Rated impulse voltage	6kV
-Pollution degree	3
Signal area	
-Rated current	10A
-Rated voltage	250V
-Rated impulse voltage	4kV
-Pollution degree	3
Rated voltage acc. to UL	600/300V
Insulation resistance	$\geq 10^{10}\Omega$
Material	polycarbonate
Limiting temperatures	-40°C ... +125°C
Flammability acc. to UL 94	V0
Mechanical working life (mating cycles)	≥ 500
Contacts	
Power contacts	
-Material	copper alloy
-Surface	hard-silver plated hard-gold plated
-Contact resistance	$\leq 1\text{m}\Omega$
-Crimp terminal	
-mm ²	0.5-4mm ²
-AWG	20-12
Signal contacts	
-Material	copper alloy
-Surface	hard-silver plated hard-gold plated
-Contact resistance	$\leq 3\text{m}\Omega$
-Crimp terminal	
-mm ²	0.14-2.5mm ²
-AWG	25-14

Current carrying capacity

The current carrying is limited by maximum temperature of materials for inserts and contacts including terminals

Control and test procedures according to DIN EN 60512-5

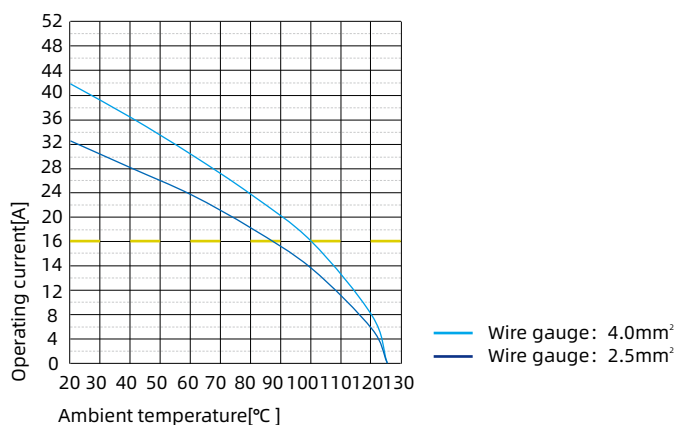

HK-008/24 Combination inserts

400/250V 16/10A 8/24+



Inserts

Hoods/Housings: size 10B, please find the details on page 15-39~15-69.

Crimp terminal

order crimp contacts separately



Insert	Designation	Order No.
Male	HK-008/24-MC	128 032 010 0001
Female	HK-008/24-FC	128 032 020 0001

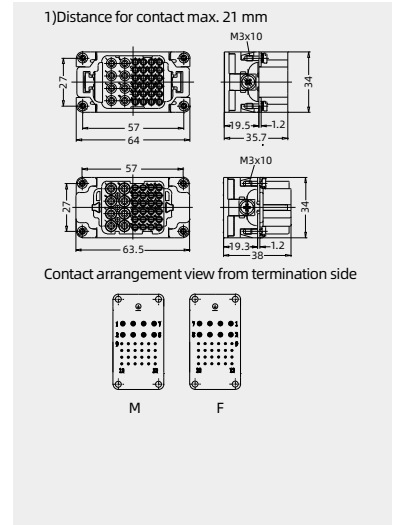

Crimp contacts

Crimp contacts 10A

Contact resistance $\leq 3m\Omega$
silver plated



gold plated



More crimp contacts 10A see P13-02, P13-03.

Male	Order No.	Female	Order No.
CDSM-0.25	101 017 110 0101	CDSF-0.25	101 017 120 0101
CDSM-0.37	101 017 110 0301	CDSF-0.37	101 017 120 0301
CDSM-0.50	101 017 110 0401	CDSF-0.50	101 017 120 0401
CDSM-0.75	101 017 110 0601	CDSF-0.75	101 017 120 0601
CDSM-1.0	101 017 110 0801	CDSF-1.0	101 017 120 0801
CDSM-1.5	101 017 110 0901	CDSF-1.5	101 017 120 0901
CDSM-2.5	101 017 110 1001	CDSF-2.5	101 017 120 1001
CDGM-0.25	101 017 210 0101	CDGF-0.25	101 017 220 0101
CDGM-0.37	101 017 210 0301	CDGF-0.37	101 017 220 0301
CDGM-0.50	101 017 210 0401	CDGF-0.50	101 017 220 0401
CDGM-0.75	101 017 210 0601	CDGF-0.75	101 017 220 0601
CDGM-1.0	101 017 210 0801	CDGF-1.0	101 017 220 0801
CDGM-1.5	101 017 210 0901	CDGF-1.5	101 017 220 0901
CDGM-2.5	101 017 210 1001	CDGF-2.5	101 017 220 1001

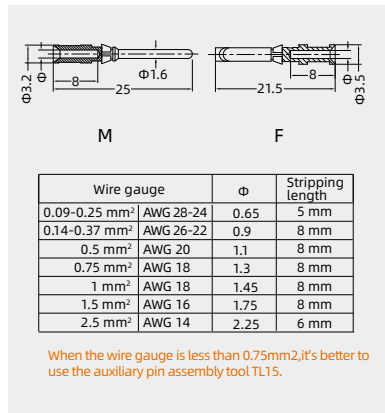

Crimp contacts 16A

silver plated



gold plated



More crimp contacts 16A see P13-04.

Male	Order No.	Female	Order No.
CESM-0.37	101 019 110 0301	CESF-0.37	101 019 120 0301
CESM-0.50	101 019 110 0401	CESF-0.50	101 019 120 0401
CESM-0.75	101 019 110 0601	CESF-0.75	101 019 120 0601
CESM-1.0	101 019 110 0801	CESF-1.0	101 019 120 0801
CESM-1.5	101 019 110 0901	CESF-1.5	101 019 120 0901
CESM-2.5	101 019 110 1001	CESF-2.5	101 019 120 1001
CESM-3.0	101 019 110 1101	CESF-3.0	101 019 120 1101
CESM-4.0	101 019 110 1201	CESF-4.0	101 019 120 1201
CEGM-0.37	101 019 210 0301	CEGF-0.37	101 019 220 0301
CEGM-0.50	101 019 210 0401	CEGF-0.50	101 019 220 0401
CEGM-0.75	101 019 210 0601	CEGF-0.75	101 019 220 0601
CEGM-1.0	101 019 210 0801	CEGF-1.0	101 019 220 0801
CEGM-1.5	101 019 210 0901	CEGF-1.5	101 019 220 0901
CEGM-2.5	101 019 210 1001	CEGF-2.5	101 019 220 1001
CEGM-3.0	101 019 210 1101	CEGF-3.0	101 019 220 1101
CEGM-4.0	101 019 210 1201	CEGF-4.0	101 019 220 1201

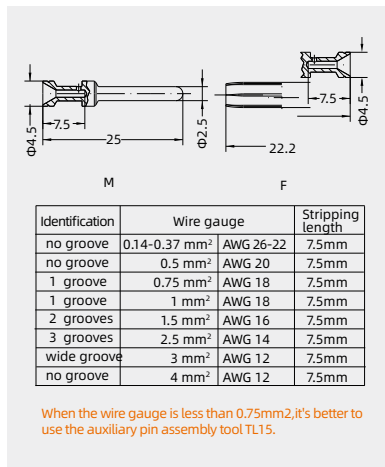

Tools

Crimping tool



Contact removal tool



Wire gauge	Designation	Order No.
0.14-4mm ²	TL02G	198 001 001 0011
Wire gauge: 16A crimp contacts 0.14-0.37mm ² please select TL02 crimping tool.		
Application	Designation	Order No.
for crimp contacts 10A	TL00	198 001 000 0001
16A contact removal tool: cross-slotted screw driver(size 0 acc. to DIN 5260).		

Notes: The tools for crimp terminal may influence the product quality and stability. Please select the tools recognized by our company.

HK-004/4 Combination crimp inserts

Technical characteristics

Specifications	DIN EN 60 664 DIN EN 61 984
Approvals	
Inserts	C € ERI
Number of contacts	4/4+PE
Electrical data acc. to EN 61 984	
Power area	
-Rated current	70A
-Rated voltage	690V
-Rated impulse voltage	8kV
-Pollution degree	3
Signal area	
-Rated current	16A
-Rated voltage	250V
-Rated impulse voltage	4kV
-Pollution degree	3
Rated voltage acc. to UL	600/230V
Insulation resistance	$\geq 10^{10}\Omega$
Material	polycarbonate
Limiting temperatures	-40°C ...+125°C
Flammability acc. to UL 94	V0
Mechanical working life (mating cycles)	≥ 500
Contacts	
Power contacts	
-Material	copper alloy
-Surface	hard-silver plated
-Contact resistance	$\leq 0.5m\Omega$
-Crimp terminal	
- wire gauge	10-25mm ²
-Max. insulation diameter	11mm
Stripping length	15.5mm
Signal contacts	
-Material	copper alloy
-Surface	hard-silver plated
-Contact resistance	$\leq 1m\Omega$
-Crimp terminal	
-mm ²	0.14-4mm ²
-AWG	26-12

Current carrying capacity

The current carrying is limited by maximum temperature of materials for inserts and contacts including terminals

Control and test procedures according to DIN EN 60512-5

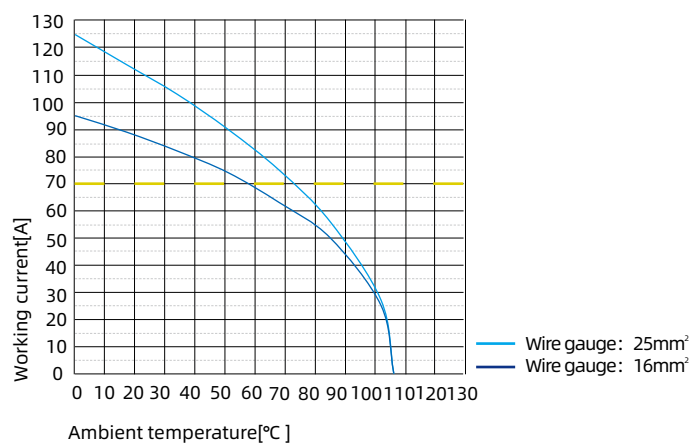

HK-004/4 Combination crimp inserts

690/250V 70/16A 4/4+⊕

CE

Inserts

Hoods/Housings: size 10B, please find the details on page 15-39~15-69.

Crimp terminal

order crimp contacts separately



Insert	Designation	Order No.
Male	HK-004/4-MC	128 008 010 0001
Female	HK-004/4-FC	128 008 020 0001

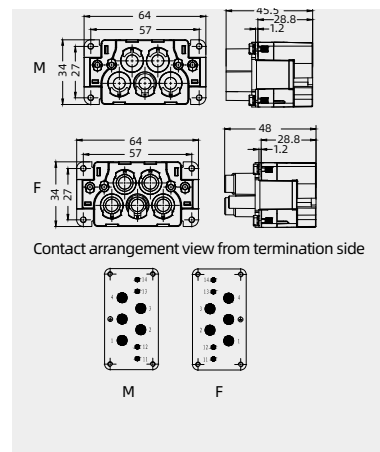

Contact arrangement view from termination side

Crimp contacts

Crimp contacts 70A

silver plated

Contact resistance ≤ 0.5mΩ



PE Contact



Male	Order No.	Female	Order No.
CKSM70-6	101 034 110 1301	CKSF70-6	101 034 120 1301
CKSM70-10	101 034 110 1401	CKSF70-10	101 034 120 1401
CKSM70-16	101 034 110 1501	CKSF70-16	101 034 120 1501
CKSM70-25	101 034 110 1601	CKSF70-25	101 034 120 1601
CKSM70PE-10	101 034 110 1404	CKSF70PE-10	101 034 120 1404
CKSM70PE-16	101 034 110 1504	CKSF70PE-16	101 034 120 1504
CKSM70PE-25	101 034 110 1604	CKSF70PE-25	101 034 120 1604

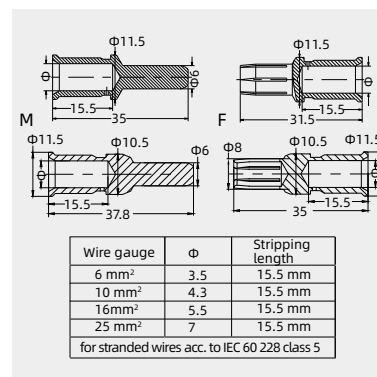

Crimp contacts 16A

silver plated

Contact resistance ≤ 1mΩ



Male	Order No.	Female	Order No.
CESM-0.37	101 019 110 0301	CESF-0.37	101 019 120 0301
CESM-0.50	101 019 110 0401	CESF-0.50	101 019 120 0401
CESM-0.75	101 019 110 0601	CESF-0.75	101 019 120 0601
CESM-1.0	101 019 110 0801	CESF-1.0	101 019 120 0801
CESM-1.5	101 019 110 0901	CESF-1.5	101 019 120 0901
CESM-2.5	101 019 110 1001	CESF-2.5	101 019 120 1001
CESM-3.0	101 019 110 1101	CESF-3.0	101 019 120 1101
CESM-4.0	101 019 110 1201	CESF-4.0	101 019 120 1201

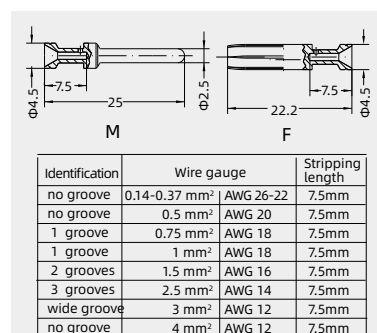

When the wire gauge is less than 0.75mm², it's better to use the auxiliary pin assembly tool TL15.

More crimp contacts 16A see P13-04.

Tools

Manual hydraulic clamp



Wire gauge	Designation	Order No.
10-240mm ²	TL05	198 001 001 0005

Crimping tool



Wire gauge	Designation	Order No.
0.5-4mm ²	TL02G	198 001 001 0011

Wire gauge: 16A crimp contacts 0.14-0.37mm² please select TL02 crimping tool.

Contact removal tool



Application	Designation	Order No.
70A 冷压针	TL12	198 001 000 0024
16A 冷压针	TL01	198 001 000 0002

Notes: The tools for crimp terminal may influence the product quality and stability. Please select the tools recognized by our company.

HK-004/4 Combination inserts



Technical characteristics

Specifications	DIN EN 60 664 DIN EN 61 984
Approvals	
Inserts	
Number of contacts	4/4+PE
Electrical data acc. to EN 61 984	
Power area	
-Rated current	63A
-Rated voltage	690V
-Rated impulse voltage	8kV
-Pollution degree	3
Signal area	
-Rated current	16A
-Rated voltage	250V
-Rated impulse voltage	4kV
-Pollution degree	3
Rated voltage acc. to UL	600/230V
Insulation resistance	$\geq 10^{10}\Omega$
Material	polycarbonate
Limiting temperatures	-40°C ...+125°C
Flammability acc. to UL 94	V0
Mechanical working life(mating cycles)	≥ 500
Contacts	
Power contacts	
-Material	copper alloy
-Surface	hard-silver plated
-Contact resistance	$\leq 0.5m\Omega$
-Screw terminal	
- geometric wire gauge	6-22mm ²
- AWG	8-4
-Max. insulation diameter	11mm
-Stripping length	11mm
Signal contacts	
-Material	copper alloy
-Surface	hard-silver plated
-Contact resistance	$\leq 3m\Omega$
-Spring terminal	
-mm ²	0.14-2.5mm ²
-AWG	26-14
-Stripping length	7-9mm

HK-004/4 Combination inserts

690/250V 63/16A 4/4+⊕



Inserts

Hoods/Housings: only suitable for size 10B high structure shells, please find the details on page 15-39~15-69.

Screw terminal



Insert	Designation	Order No.
Male	HK-004/4.1-M(6-16mm ²)	128 008 011 0002
	HK-004/4.2-M(14-22mm ²)	128 008 011 0003
Female	HK-004/4.1-F(6-16mm ²)	128 008 021 0002
	HK-004/4.2-F(14-22mm ²)	128 008 021 0003

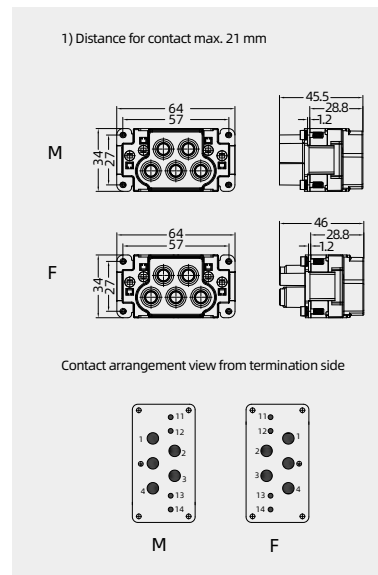

Accessories

Tool

hexagonal driver



Description	Designation	Order No.
for axial setscrew with grip	SW-2.5*100	198 001 003 0003

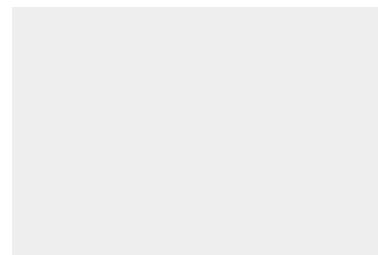

HK-004/0,004/2 Combination inserts



Technical characteristics

Specifications	DIN EN 60 664 DIN EN 61 984
Approvals	
Inserts	
Number of contacts	4/0+PE,4/2+PE
Electrical data acc. to EN 61 984	
Power area	
-Rated current	80A
-Rated voltage	830V
-Rated impulse voltage	8kV
-Pollution degree	3
-Pollution degree 2 also	80A 1000V 8kV 2
Signal area	
-Rated current	16A
-Rated voltage	400V
-Rated impulse voltage	6kV
-Pollution degree	3
-Pollution degree 2 also	16A 400/690V 6kV 2
Rated voltage acc. to UL	600/300V
Insulation resistance	$\geq 10^{10}\Omega$
Material	polycarbonate
Limiting temperatures	-40°C ...+125°C
Flammability acc. to UL 94	V0
Mechanical working life(mating cycles)	≥ 500
Contacts	
Power contacts	
-Material	copper alloy
-Surface	hard-silver plated
-Contact resistance	$\leq 0.3m\Omega$
-Screw terminal	
- geometric wire gauge	1.5-16mm ²
- AWG	16-6
-Tightening torque	
-mm ²	1.5 2.5 4 6 10 16
-N.m	1.2 2 3 3 3 3
-Stripping length	14mm
Signal contacts	
-Material	copper alloy
-Surface	hard-silver plated
-Contact resistance	$\leq 1m\Omega$
-Screw terminal	
-mm ²	0.5-2.5mm ²
-AWG	20-14
-Tightening torque	0.5Nm
-Stripping length	7.5mm

Current carrying capacity

The current carrying is limited by maximum temperature of materials for inserts and contacts including terminals

Control and test procedures according to DIN EN 60512-5

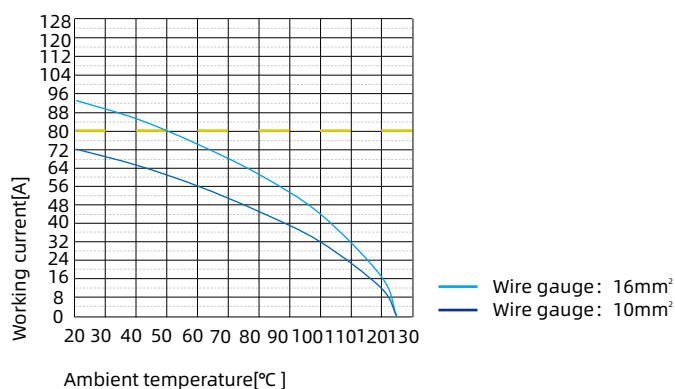

HK-004/0,004/2 Combination inserts

830/400V 80/16A 4/0,4/2+⊕



Inserts

Hoods/Housings: size 16B, please find the details on page 15-70~15-1071.

Screw terminal



Insert	Designation	Order No.
Male	HK-004/0-M	128 004 011 0001
Female	HK-004/0-F	128 004 021 0001

Screw terminal



Insert	Designation	Order No.
Male	HK-004/2-M	128 006 011 0001
Female	HK-004/2-F	128 006 021 0001

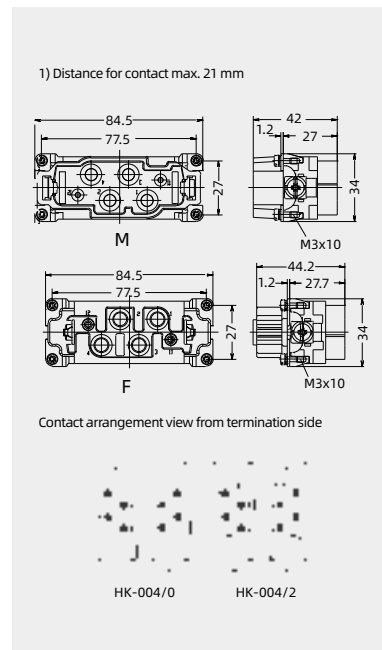

HK-004/8 Combination inserts



Technical characteristics

Specifications	DIN EN 60 664 DIN EN 61 984
Approvals	
Inserts	
Number of contacts	4/8+PE
Electrical data acc. to EN 61 984	
Power area	
-Rated current	80A
-Rated voltage	400V
-Rated impulse voltage	6kV
-Pollution degree	3
Signal area	
-Rated current	16A
-Rated voltage	400V
-Rated impulse voltage	6kV
-Pollution degree	3
Rated voltage acc. to UL	600/600V
Insulation resistance	$\geq 10^{10}\Omega$
Material	polycarbonate
Limiting temperatures	-40°C ...+125°C
Flammability acc. to UL 94	V0
Mechanical working life(mating cycles)	≥ 500
Contacts	
Power contacts	
-Material	copper alloy
-Surface	hard-silver plated
-Contact resistance	$\leq 0.3m\Omega$
-Screw terminal	
- geometric wire gauge	1.5-16mm ²
- AWG	16-6
-Tightening torque	
-mm ²	1.5 2.5 4 6 10 16
-N.m	1.2 2 3 3 3 3
-Stripping length	14mm
Signal contacts	
-Material	copper alloy
-Surface	hard-silver plated
-Contact resistance	$\leq 1m\Omega$
-Screw terminal	
-mm ²	0.5-2.5mm ²
-AWG	20-14
-Tightening torque	0.5Nm
-Stripping length	7.5mm

Current carrying capacity

The current carrying is limited by maximum temperature of materials for inserts and contacts including terminals

Control and test procedures according to DIN EN 60512-5

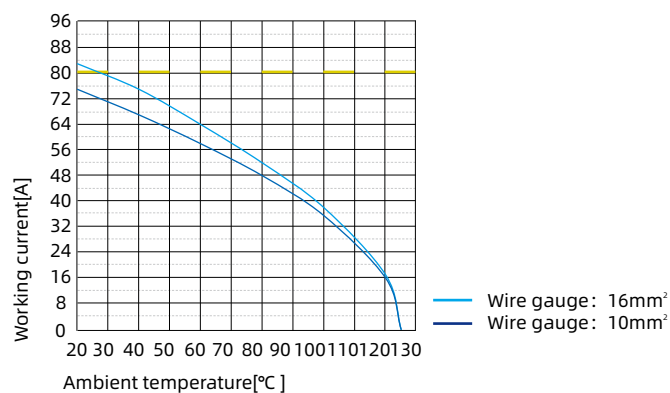

HK-004/8 Combination inserts

400/400V 80/16A 4/8+⊕



Inserts

Hoods/Housings: size 24B, please find the details on page 15-108-15-150.

Screw terminal



Insert	Designation	Order No.
Male	HK-004/8-M	128 012 011 0001
Female	HK-004/8-F	128 012 021 0001

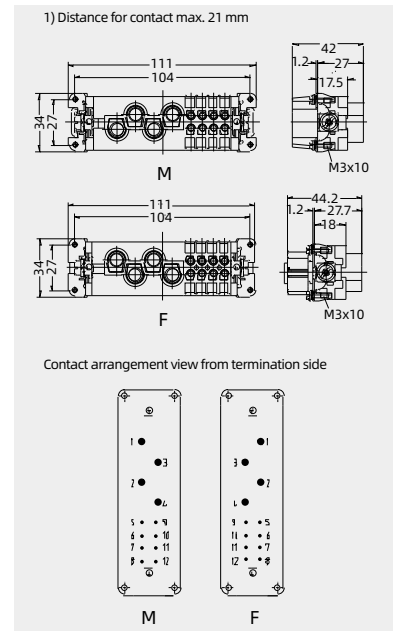

HWK-006/6 Combination inserts



Technical characteristics

Technical characteristics	DIN EN 60 664 DIN EN 61 984
Approvals	
Inserts	
Number of contacts	6/6+PE
Electrical data acc. to EN 61 984	
Power area	
-Rated current	40A
-Rated voltage	690V
-Rated impulse voltage	8kV
-Pollution degree	3
Signal area	
-Rated current	16A
-Rated voltage	400V
-Rated impulse voltage	6kV
-Pollution degree	3
Rated voltage acc. to UL	600/600V
Insulation resistanc	$\geq 10^{10}\Omega$
Material	polycarbonate
Limiting temperatures	-40°C ...+125°C
Flammability acc. to UL 94	V0
Mechanical working life(mating cycles)	≥ 500
Contacts	
Material	copper alloy
Surface	hard-silver plated
Terminal	screw terminal
Contact resistance	
-power area	$\leq 1m\Omega$
-signal area	$\leq 1m\Omega$
Wire gauge	
-power area	
-mm ²	4-10mm ²
-AWG	12-8
-signal area	
-mm ²	1-2.5mm ²
-AWG	18-4
Tightening torque	
-power area	mm ² 1.5 2.5 4 6 10 N.m 1.2 2 3 3 3
-signal area	0.5N.m

Current carrying capacity

The current carrying is limited by maximum temperature of materials for inserts and contacts including terminals

Control and test procedures according to DIN EN 60512-5

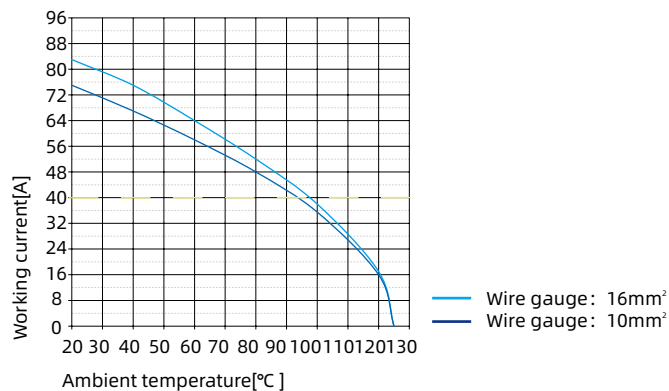

HWK-006/6 Combination inserts

690/400V 40/16A 6/6+ 

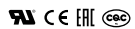

Inserts

Hoods/Housings: size 16B, please find the details on page 15-70~15-1071.

Screw terminal



Insert	Designation	Order No.
Male	HWK-006/6-M	128 012 011 0201
Female	HWK-006/6-F	128 012 021 0201

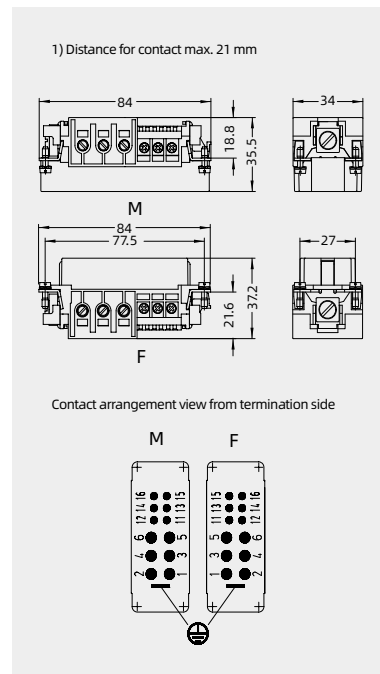

HK-006/12 Combination inserts



Technical characteristics

Specifications	DIN EN 60 664 DIN EN 61 984
Approvals	
Inserts	
Number of contacts	6/12+PE
Electrical data acc. to EN 61 984	
Power area	
Rated current	40A
Rated voltage	690V
Rated impulse voltage	6kV
Pollution degree	3
Signal area	
Rated current	10A
Rated voltage conductor	230/400V
Rated impulse voltage	4kV
Pollution degree	3
Rated voltage acc. to UL	600/300V
Insulation resistance	$\geq 10^{10}\Omega$
Material	polycarbonate
Limiting temperatures	-40°C ...+125°C
Flammability acc. to UL 94	V0
Mechanical working life(mating cycles)	≥ 500
Contacts	
Power contacts	
-Material	copper alloy
-Surface	hard-silver plated
-Contact resistance	$\leq 1m\Omega$
-Axial screw termination	
- geometric wire gauge	2.5-10mm ²
- AWG	14-8
-Max. insulation diameter	6.1mm
-Tightening torque	
-mm ²	2.5 4 6 10
-Nm	1.5 1.5 2 2
-Stripping length	
-mm ²	2.5 4 6 10
-mm	5 ⁺¹ 5 ⁺¹ 8 ⁺¹ 8 ⁺¹
Signal contacts	
-Material	copper alloy
-Surface	hard-silver plated
-Contact resistance	$\leq 3m\Omega$
-Screw terminal	
- geometric wire gauge	0.2-2.5mm ²
- AWG	24-14
-Tightening torque	0.8Nm
-Stripping length	7.5mm

Current carrying capacity

The current carrying is limited by maximum temperature of materials for inserts and contacts including terminals

Control and test procedures according to DIN EN 60512-5

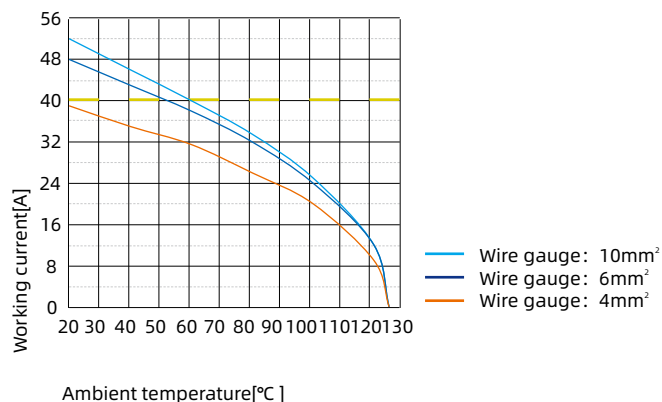

HK-006/12 Combination inserts

690/400V 40/10A 6/12+ 



Inserts

Hoods/Housings: size 16B, please find the details on page 15-70~15-1071.

Axial screw terminal¹⁾/Screw terminal



Insert	Wire gauge	Designation	Order No.
Male	2.5-8mm ²	HK-006.1/12-M(2.5-8mm ²)	128 018 011 0001
	6-10mm ²	HK-006.2/12-M(6-10mm ²)	128 018 011 0002
Female	2.5-8mm ²	HK-006.1/12-F(2.5-8mm ²)	128 018 021 0001
	6-10mm ²	HK-006.2/12-F(6-10mm ²)	128 018 021 0002

1) See P00-12~00-13 for the structural characteristics and description of Axial screw terminal.

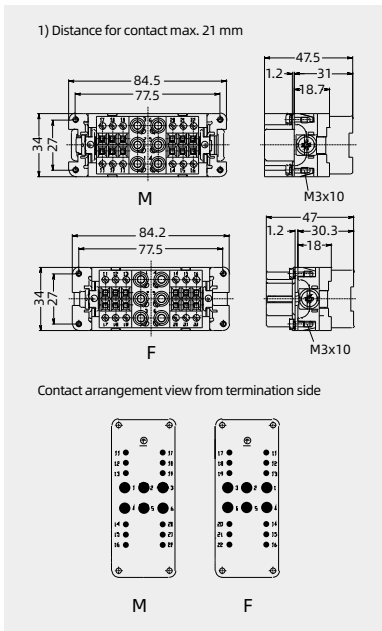

Accessories

Tool

hexagonal driver



Description	Designation	Order No.
for axial setscrew with grip	SW-2*100	198 001 003 0002

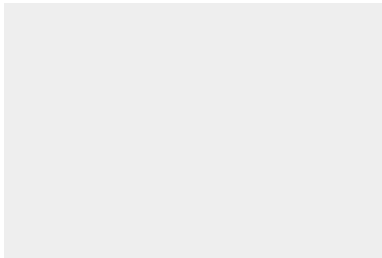

HK-006/36 Combination inserts



Technical characteristics

Specifications	DIN EN 60 664 DIN EN 61 984
Approvals	
Inserts	
Number of contacts	6/36+PE
Electrical data acc. to EN 61 984	
Power area	
-Rated current	40A
-Rated voltage	690V
-Rated impulse voltage	8kV
-Pollution degree	3
Signal area	
-Rated current	10A
-Rated voltage	160V
-Rated impulse voltage	2.5kV
-Pollution degree	3
-Pollution degree 2 also	10A 250V 4kV 2
Rated voltage acc. to UL	600/300V
Insulation resistance	$\geq 10^{10}\Omega$
Material	polycarbonate
Limiting temperatures	-40°C ...+125°C
Flammability acc. to UL 94	V0
Mechanical working life(mating cycles)	≥ 500
Contacts	
Power contacts	
-Material	copper alloy
-Surface	hard-silver plated hard-gold plated
-Contact resistance	$\leq 1m\Omega$
-Crimp terminal	
- mm ²	1.5-6mm ²
- AWG	16-10
-Max. insulation diameter	5mm
Signal contacts	
-Material	copper alloy
-Surface	hard-silver plated hard-gold plated
-Contact resistance	$\leq 3m\Omega$
-Crimp terminal	
- mm ²	0.14-2.5mm ²
- AWG	26-14

Current carrying capacity

The current carrying is limited by maximum temperature of materials for inserts and contacts including terminals

Control and test procedures according to DIN EN 60512-5

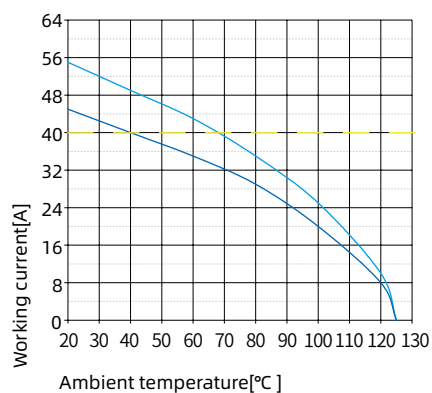

Wire gauge: 10mm²
Wire gauge: 6mm²
Wire gauge: 4mm²

HK-006/36 Combination inserts

690/160V 40/10A 6/36+⊕



Inserts

Hoods/Housings: size 16B, please find the details on page 15-70~15-1071.

Crimp terminal

order crimp contacts separately



Insert	Designation	Order No.
Male	HK-006/36-MC	128 042 010 0001
Female	HK-006/36-FC	128 042 020 0001

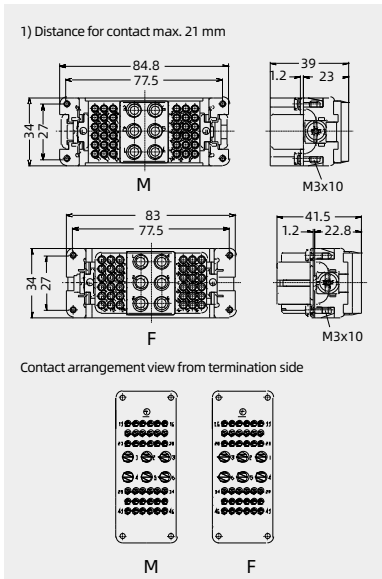

Crimp contacts

Crimp contacts 10A

Contact resistance $\leq 3m\Omega$
silver plated



gold plated



More crimp contacts 10A
see P13-02,P13-03.

Male	Order No.	Female	Order No.
CDSM-0.25	101 017 110 0101	CDSF-0.25	101 017 120 0101
CDSM-0.37	101 017 110 0301	CDSF-0.37	101 017 120 0301
CDSM-0.50	101 017 110 0401	CDSF-0.50	101 017 120 0401
CDSM-0.75	101 017 110 0601	CDSF-0.75	101 017 120 0601
CDSM-1.0	101 017 110 0801	CDSF-1.0	101 017 120 0801
CDSM-1.5	101 017 110 0901	CDSF-1.5	101 017 120 0901
CDSM-2.5	101 017 110 1001	CDSF-2.5	101 017 120 1001
CDGM-0.25	101 017 210 0101	CDGF-0.25	101 017 220 0101
CDGM-0.37	101 017 210 0301	CDGF-0.37	101 017 220 0301
CDGM-0.50	101 017 210 0401	CDGF-0.50	101 017 220 0401
CDGM-0.75	101 017 210 0601	CDGF-0.75	101 017 220 0601
CDGM-1.0	101 017 210 0801	CDGF-1.0	101 017 220 0801
CDGM-1.5	101 017 210 0901	CDGF-1.5	101 017 220 0901
CDGM-2.5	101 017 210 1001	CDGF-2.5	101 017 220 1001

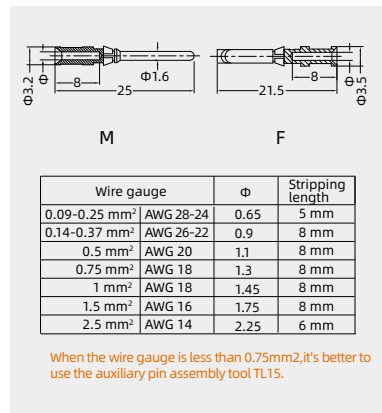

Crimp contacts 40A

silver plated



gold plated



Male	Order No.	Female	Order No.
CCSM-1.5	101 023 110 0901	CCSF-1.5	101 023 120 0901
CCSM-2.5	101 023 110 1001	CCSF-2.5	101 023 120 1001
CCSM-4.0	101 023 110 1201	CCSF-4.0	101 023 120 1201
CCSM-6.0	101 023 110 1301	CCSF-6.0	101 023 120 1301
CCGM-1.5	101 023 210 0901	CCGF-1.5	101 023 220 0901
CCGM-2.5	101 023 210 1001	CCGF-2.5	101 023 220 1001
CCGM-4.0	101 023 210 1201	CCGF-4.0	101 023 220 1201
CCGM-6.0	101 023 210 1301	CCGF-6.0	101 023 220 1301

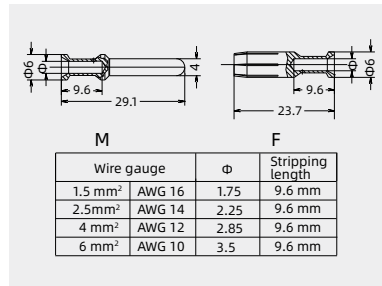

Tools

Crimping tool



Contact removal tool



Wire gauge	Designation	Order No.
0.14-4mm ²	TL02G	198 001 001 0011
1.5-6mm ²	TL02-0G	198 001 001 0012

Application	Designation	Order No.
for crimp contacts 10A	TL00	198 001 000 0001

Application	Designation	Order No.
for crimp contacts 40A	TL06G	198 001 000 0009

Notes: The tools for crimp terminal may influence the product quality and stability. Please select the tools recognized by our company.

HK-012/2 Combination inserts



Technical characteristics

Specifications	DIN EN 60 664 DIN EN 61 984
Approvals	
Inserts	
Number of contacts	12/2+PE
Electrical data acc. to EN 61 984	
Power area	
-Rated current	40A
-Rated voltage	690V
-Rated impulse voltage	8kV
-Pollution degree	3
Signal area	
-Rated current	10A
-Rated voltage	250V
-Rated impulse voltage	4kV
-Pollution degree	3
Rated voltage acc. to UL	600/300V
Insulation resistance	$\geq 10^{10}\Omega$
Material	polycarbonate
Limiting temperatures	-40°C ...+125°C
Flammability acc. to UL 94	V0
Mechanical working life(mating cycles)	≥ 500
Contacts	
Power contacts	
-Material	copper alloy
-Surface	hard-silver plated hard-gold plated
-Contact resistance	$\leq 1m\Omega$
-Crimp terminal	
- mm ²	1.5-6mm ²
- AWG	16-10
Signal contacts	
-Material	copper alloy
-Surface	hard-silver plated hard-gold plated
-Contact resistance	$\leq 3m\Omega$
-Crimp terminal	
- mm ²	0.14-2.5mm ²
- AWG	26-14

Current carrying capacity

The current carrying is limited by maximum temperature of materials for inserts and contacts including terminals

Control and test procedures according to DIN EN 60512-5

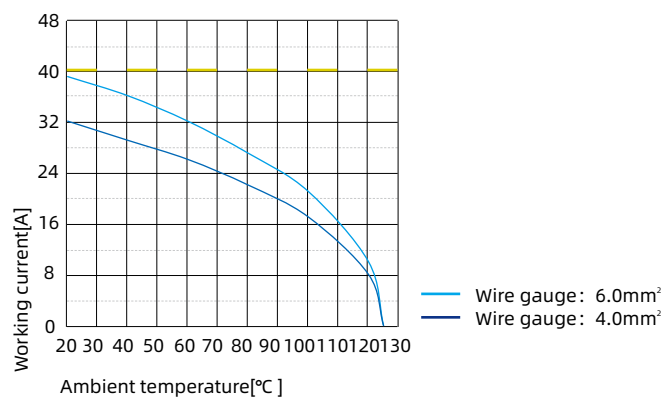

HK-012/2 Combination inserts

690/250V 40/10A 12/2+⊕



Inserts

Hoods/Housings: size 16B, please find the details on page 15-70~15-1071.

Crimp terminal

order crimp contacts separately



Insert	Designation	Order No.
Male	HK-012/2-MC	128 014 010 0001
Female	HK-012/2-FC	128 014 020 0001

1) Distance for contact max. 21 mm

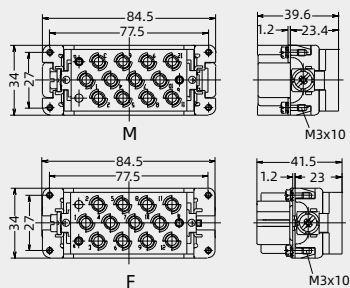

Contact arrangement view from termination side

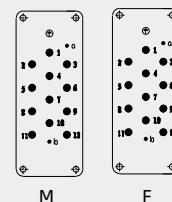

Crimp contacts

Crimp contacts 10A

Contact resistance ≤ 3mΩ
silver plated



gold plated



More crimp contacts 10A
see P13-02,P13-03.

Male	Order No.	Female	Order No.
CDSM-0.25	101 017 110 0101	CDSF-0.25	101 017 120 0101
CDSM-0.37	101 017 110 0301	CDSF-0.37	101 017 120 0301
CDSM-0.50	101 017 110 0401	CDSF-0.50	101 017 120 0401
CDSM-0.75	101 017 110 0601	CDSF-0.75	101 017 120 0601
CDSM-1.0	101 017 110 0801	CDSF-1.0	101 017 120 0801
CDSM-1.5	101 017 110 0901	CDSF-1.5	101 017 120 0901
CDSM-2.5	101 017 110 1001	CDSF-2.5	101 017 120 1001
CDGM-0.25	101 017 210 0101	CDGF-0.25	101 017 220 0101
CDGM-0.37	101 017 210 0301	CDGF-0.37	101 017 220 0301
CDGM-0.50	101 017 210 0401	CDGF-0.50	101 017 220 0401
CDGM-0.75	101 017 210 0601	CDGF-0.75	101 017 220 0601
CDGM-1.0	101 017 210 0801	CDGF-1.0	101 017 220 0801
CDGM-1.5	101 017 210 0901	CDGF-1.5	101 017 220 0901
CDGM-2.5	101 017 210 1001	CDGF-2.5	101 017 220 1001

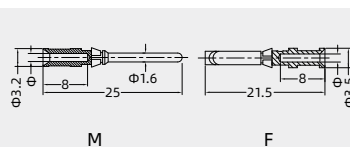

Wire gauge	Φ	Stripping length
0.09-0.25 mm ²	AWG 28-24	0.65 5 mm
0.14-0.37 mm ²	AWG 26-22	0.9 8 mm
0.5 mm ²	AWG 20	1.1 8 mm
0.75 mm ²	AWG 18	1.3 8 mm
1 mm ²	AWG 18	1.45 8 mm
1.5 mm ²	AWG 16	1.75 8 mm
2.5 mm ²	AWG 14	2.25 6 mm

When the wire gauge is less than 0.75mm², it's better to use the auxiliary pin assembly tool TL15.

Crimp contacts 40A

silver plated



gold plated



Male	Order No.	Female	Order No.
CCSM-1.5	101 023 110 0901	CCSF-1.5	101 023 120 0901
CCSM-2.5	101 023 110 1001	CCSF-2.5	101 023 120 1001
CCSM-4.0	101 023 110 1201	CCSF-4.0	101 023 120 1201
CCSM-6.0	101 023 110 1301	CCSF-6.0	101 023 120 1301
CCGM-1.5	101 023 210 0901	CCGF-1.5	101 023 220 0901
CCGM-2.5	101 023 210 1001	CCGF-2.5	101 023 220 1001
CCGM-4.0	101 023 210 1201	CCGF-4.0	101 023 220 1201
CCGM-6.0	101 023 210 1301	CCGF-6.0	101 023 220 1301

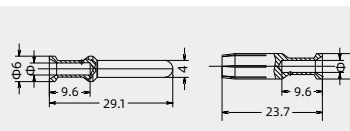

Wire gauge	Φ	Stripping length
1.5 mm ²	AWG 16	1.75 9.6 mm
2.5mm ²	AWG 14	2.25 9.6 mm
4 mm ²	AWG 12	2.85 9.6 mm
6 mm ²	AWG 10	3.5 9.6 mm

Tools

Crimping tool



Contact removal tool



Wire gauge	Designation	Order No.
0.14-4mm ²	TL02G	198 001 001 0011
1.5-6mm ²	TL02-0G	198 001 001 0012
Application	Designation	Order No.
for crimp contacts 10A	TL00	198 001 000 0001
Application	Designation	Order No.
for crimp contacts 40A	TL06G	198 001 000 0009

Notes: The tools for crimp terminal may influence the product quality and stability. Please select the tools recognized by our company.

HKH-012/0 Combination high mating cycle inserts



Technical characteristics

Specifications	DIN EN 60 664 DIN EN 61 984
Approvals	CE ENEC
Inserts	
Number of contacts	12/0+PE
Electrical data acc. to EN 61 984	
Power area	
-Rated current	40A
-Rated voltage	690V
-Rated impulse voltage	8kV
-Pollution degree	3
Rated voltage acc. to UL	600/300V
Insulation resistance	$\geq 10^{10}\Omega$
Material	polycarbonate
Limiting temperatures	-40°C ...+125°C
Flammability acc. to UL 94	V0
Mechanical working life(mating cycles) ≥ 5000	
Contacts	
Power contacts	
-Material	copper alloy
-Surface	hard-gold plated
-Contact resistance	$\leq 1m\Omega$
-Crimp terminal	
-mm ²	1.5-6mm ²
-AWG	16-10

Current carrying capacity

The current carrying is limited by maximum temperature of materials for inserts and contacts including terminals

Control and test procedures according to DIN EN 60512-5

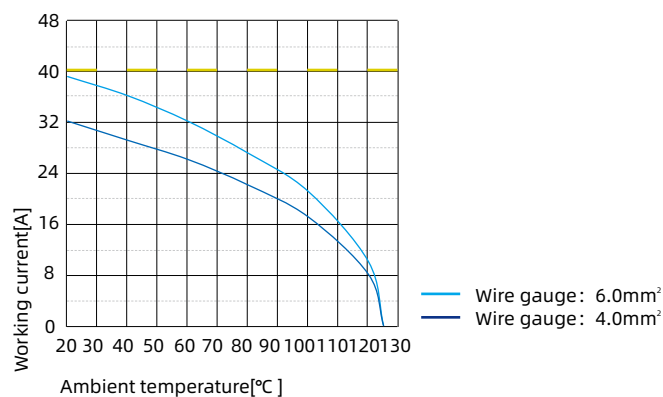

HKH-012/0 Combination high mating cycle inserts

690V 40A 12/0+

CE

Inserts

Hoods/Housings: size **16B**, please find the details on page 15-70~15-1071.

Crimp terminal

order crimp contacts separately



Insert	Designation	Order No.
Male	HKH-012/0-MC	128 012 010 0001
Female	HKH-012/0-FC	128 012 020 0001

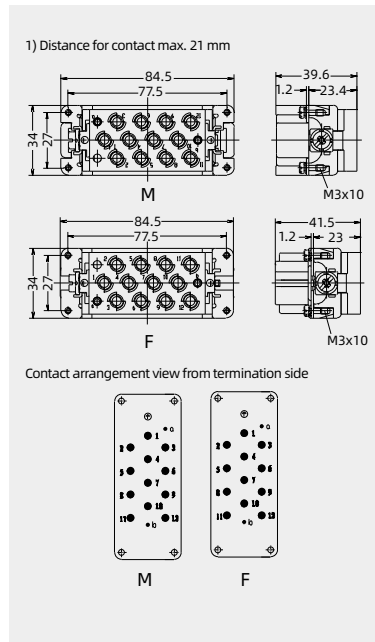

Crimp contacts

Crimp contacts 40A-high mating cycle

gold plated

Mechanical working life
(mating cycles) ≥ 5000



Male	Order No.	Female	Order No.
CCGMH-1.5	101 023 210 0909	CCGFH-1.5G	101 023 220 0909
CCGMH-2.5	101 023 210 1009	CCGFH-2.5G	101 023 220 1009
CCGMH-4.0	101 023 210 1209	CCGFH-4.0G	101 023 220 1209
CCGMH-6.0	101 023 210 1309	CCGFH-6.0G	101 023 220 1309
CCGMH-10.0	101 023 210 1409	CCGFH-10.0G	101 023 220 1409

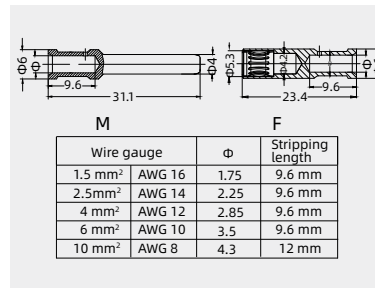

Tools

Crimping tool



Contact removal tool



Wire gauge	Designation	Order No.
1.5-6mm ²	TL02-0G	198 001 001 0012
4/6/10mm ²	TL02-3G	198 001 001 0013

Application	Designation	Order No.
40A 冷压针	TL06G	198 001 000 0009

Notes: The tools for crimp terminal may influence the product quality and stability. Please select the tools recognized by our company.

HK-006/6 Combination inserts



Technical characteristics

Specifications	DIN EN 60 664 DIN EN 61 984
Approvals	VDE CE ENEC
Inserts	
Number of contacts	6/6+PE
Electrical data acc. to EN 61 984	
Power area	
-Rated current	100A
-Rated voltage	690V
-Rated impulse voltage	8kV
-Pollution degree	3
-Pollution degree 2 also	100A 1000V 8kV 2
Signal area	
-Rated current	16A
-Rated voltage	400V
-Rated impulse voltage	6kV
-Pollution degree	3
Rated voltage acc. to UL	600/300V
Insulation resistance	$\geq 10^{10}\Omega$
Material	polycarbonate
Limiting temperatures	-40°C ...+125°C
Flammability acc. to UL 94	V0
Mechanical working life(mating cycles)	≥ 500
Contacts	
Power contacts	
-Material	copper alloy
-Surface	hard-silver plated
-Contact resistance	$\leq 0.5m\Omega$
-Axial screw termination	
- geometric wire gauge	16-35mm ²
- AWG	5-2
-Max. insulation diameter	11.4mm
-Tightening torque	
-mm ²	16 25 35
-Nm	6 7 8
-Stripping length	13 ^{±1} mm
Signal contacts	
-Material	copper alloy
-Surface	hard-silver plated
-Contact resistance	$\leq 3m\Omega$
-Screw terminal	
- geometric wire gauge	0.2-2.5mm ²
- AWG	24-13
-Tightening torque	0.8Nm
-Stripping length	7.5mm

Current carrying capacity

The current carrying is limited by maximum temperature of materials for inserts and contacts including terminals

Control and test procedures according to DIN EN 60512-5

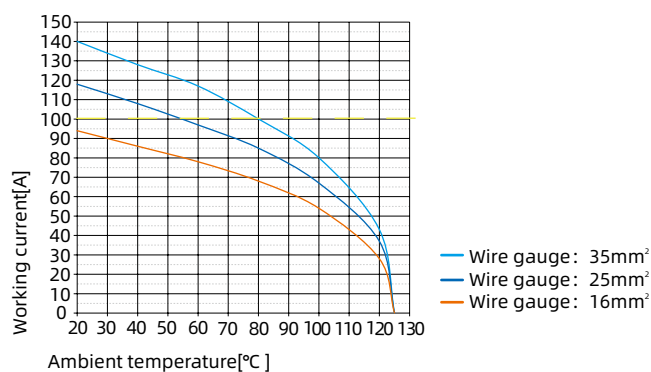

HK-006/6 Combination inserts

690/400V 100/16A 6/6+

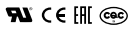

Hoods/Housings: Only suitable for size **24B** high structure shells, please find the details on page 15-108~15-135.
Not suitable for high structure shells with side entry and without sleeve.

Inserts

Axial screw terminal¹⁾/Screw terminal



Insert	Designation	Order No.
Male	HK-006/6-M	128 012 011 0101
Female	HK-006/6-F	128 012 021 0101

1) See P00-12-00-13 for the structural characteristics and description of Axial screw terminal.

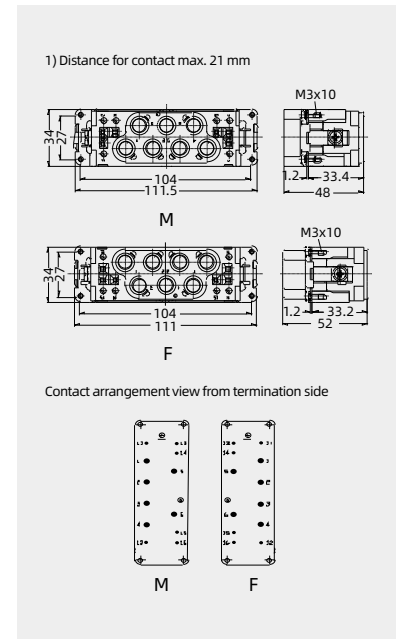

Accessories

Tool

hexagonal driver



Description	Designation	Order No.
for axial setscrew with grip	SW-4*150	198 001 003 0001

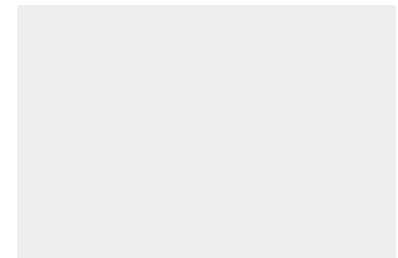

HK-008/0 Combination inserts



Technical characteristics

Specifications	DIN EN 60 664 DIN EN 61 984
Approvals	UL CE ENE CCC
Inserts	
Number of contacts	8/0+PE
Electrical data acc. to EN 61 984	
Power area	
Rated current	100A
Rated voltage	690V
Rated impulse voltage	8kV
Pollution degree	3
Pollution degree 2 also	100A 1000V 8kV 2
Rated voltage acc. to UL	600V
Rated current acc. to UL	82A
Insulation resistance	$\geq 10^{10}\Omega$
Material	polycarbonate
Limiting temperatures	-40°C ...+125°C
Flammability acc. to UL 94	V0
Mechanical working life(mating cycles)	≥ 500
Contacts	
Material	copper alloy
Surface	hard-silver plated
Contact resistance	$\leq 0.5m\Omega$
Axial screw termination	
- geometric wire gauge	10-25mm ²
- AWG	7-3
Max. insulation diameter	11.4mm
Tightening torque	
-mm ²	10 16 25
-Nm	6 6 7
Stripping length	13 ^{±1} mm

Current carrying capacity

The current carrying is limited by maximum temperature of materials for inserts and contacts including terminals

Control and test procedures according to DIN EN 60512-5

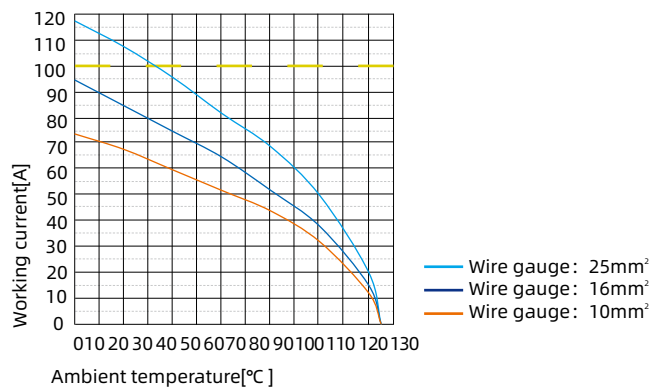

HK-008/0 Combination inserts

690V 100A 8/0+ 



Hoods/Housings: size 24B, please find the details on page 15-108~15-135.
Not suitable for high structure shells with side entry and without sleeve.

Inserts

Axial screw terminal1)/Screw terminal



Insert	Designation	Order No.
Male	HK-008/0-M	128 008 011 0001
Female	HK-008/0-F	128 008 021 0001

1) See P00-12~00-13 for the structural characteristics and description of Axial screw terminal.

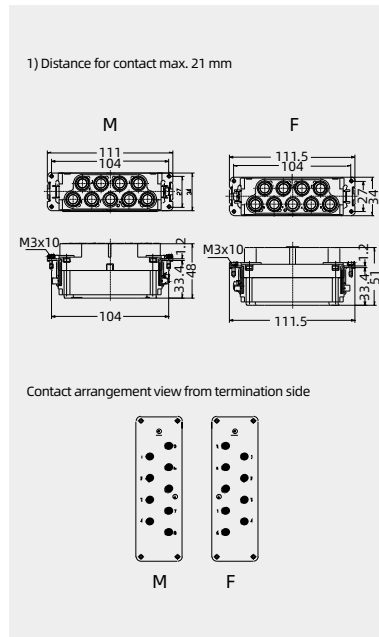

Accessories

Tool

hexagonal driver



Description	Designation	Order No.
for axial setscrew with grip	SW-4*150	198 001 003 0001

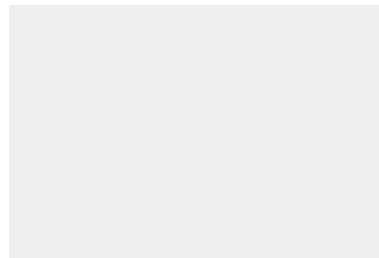

HK-009/9/18 Combination inserts



Technical characteristics

Specifications	DIN EN 60 664 DIN EN 61 984
Approvals	
Inserts	
Number of contacts	9/9/18
Electrical data acc. to EN 61 984	
Rated current	40A/16A/10A
Rated voltage	830V/830V/250V
Rated impulse voltage	8kV/8kV/4kV
Pollution degree	3
Insulation resistance	$\geq 10^{10}\Omega$
Material	polycarbonate
Limiting temperatures	-40°C ...+125°C
Flammability acc. to UL 94	V0
Mechanical working life(mating cycles)	≥ 500
Contacts	
Material	copper alloy
Surface	hard-silver plated
	hard-gold plated
Contact resistance	$\leq 3m\Omega$
Crimp terminal	
-mm ²	1.5-6mm ² / 0.14-4mm ² / 0.14-2.5mm ²
-AWG	16-10 / 26-12 / 26-14
Stripping length	9.5/7.5/8 (6)mm

830V/830V/250V 40A/16A/10A 9/9/18+



Inserts

Hoods/Housings: size 16B, please find the details on page 15-70~15-1071.

Crimp terminal

order crimp contacts separately

Insert	Designation	Order No.
Male	HK-009/9/18-MC	128 036 010 0001
Female	HK-009/9/18-FC	128 036 020 0001



To ensure that the grounding pin comes into contact first during the insertion process, it is necessary to use a guide pin/guide hole in conjunction with 1980020050017 and 1980020050018 → P14-17

Crimp contacts 10A

Contact resistance ≤ 3mΩ silver plated



gold plated



More crimp contacts 10A see P13-02,P13-03.

Male	Order No.	Female	Order No.
CDSM-0.25	101 017 110 0101	CDSF-0.25	101 017 120 0101
CDSM-0.37	101 017 110 0301	CDSF-0.37	101 017 120 0301
CDSM-0.50	101 017 110 0401	CDSF-0.50	101 017 120 0401
CDSM-0.75	101 017 110 0601	CDSF-0.75	101 017 120 0601
CDSM-1.0	101 017 110 0801	CDSF-1.0	101 017 120 0801
CDSM-1.5	101 017 110 0901	CDSF-1.5	101 017 120 0901
CDSM-2.5	101 017 110 1001	CDSF-2.5	101 017 120 1001
CDGM-0.25	101 017 210 0101	CDGF-0.25	101 017 220 0101
CDGM-0.37	101 017 210 0301	CDGF-0.37	101 017 220 0301
CDGM-0.50	101 017 210 0401	CDGF-0.50	101 017 220 0401
CDGM-0.75	101 017 210 0601	CDGF-0.75	101 017 220 0601
CDGM-1.0	101 017 210 0801	CDGF-1.0	101 017 220 0801
CDGM-1.5	101 017 210 0901	CDGF-1.5	101 017 220 0901
CDGM-2.5	101 017 210 1001	CDGF-2.5	101 017 220 1001

Crimp contacts 16A

Contact resistance ≤ 1mΩ silver plated



gold plated



More crimp contacts 16A see P13-04.

Male	Order No.	Female	Order No.
CESM-0.37	101 019 110 0301	CESF-0.37	101 019 120 0301
CESM-0.50	101 019 110 0401	CESF-0.50	101 019 120 0401
CESM-0.75	101 019 110 0601	CESF-0.75	101 019 120 0601
CESM-1.0	101 019 110 0801	CESF-1.0	101 019 120 0801
CESM-1.5	101 019 110 0901	CESF-1.5	101 019 120 0901
CESM-2.5	101 019 110 1001	CESF-2.5	101 019 120 1001
CESM-3.0	101 019 110 1101	CESF-3.0	101 019 120 1101
CESM-4.0	101 019 110 1201	CESF-4.0	101 019 120 1201
CEGM-0.37	101 019 210 0301	CEGF-0.37	101 019 220 0301
CEGM-0.50	101 019 210 0401	CEGF-0.50	101 019 220 0401
CEGM-0.75	101 019 210 0601	CEGF-0.75	101 019 220 0601
CEGM-1.0	101 019 210 0801	CEGF-1.0	101 019 220 0801
CEGM-1.5	101 019 210 0901	CEGF-1.5	101 019 220 0901
CEGM-2.5	101 019 210 1001	CEGF-2.5	101 019 220 1001
CEGM-3.0	101 019 210 1101	CEGF-3.0	101 019 220 1101
CEGM-4.0	101 019 210 1201	CEGF-4.0	101 019 220 1201

Crimp contacts 40A

silver plated



gold plated

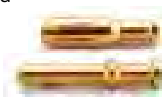

Male	Order No.	Female	Order No.
CCSM-1.5	101 023 110 0901	CCSF-1.5	101 023 120 0901
CCSM-2.5	101 023 110 1001	CCSF-2.5	101 023 120 1001
CCSM-4.0	101 023 110 1201	CCSF-4.0	101 023 120 1201
CCSM-6.0	101 023 110 1301	CCSF-6.0	101 023 120 1301
CCGM-1.5	101 023 210 0901	CCGF-1.5	101 023 220 0901
CCGM-2.5	101 023 210 1001	CCGF-2.5	101 023 220 1001
CCGM-4.0	101 023 210 1201	CCGF-4.0	101 023 220 1201
CCGM-6.0	101 023 210 1301	CCGF-6.0	101 023 220 1301

Tools

Crimping tool



Wire gauge	Designation	Order No.
0.14-4mm ²	TL02G	198 001 001 0011
1.5-6mm ²	TL02-OG	198 001 001 0012

Tools

Contact removal tool



Application	Designation	Order No.
for 10A crimp contact	TL00	198 001 000 0001
for 16A crimp contact	TL01	198 001 000 0002
for 40A crimp contact	TL06G	198 001 000 0009

Notes: The tools for crimp terminal may influence the product quality and stability. Please select the tools recognized by our company. More tools detail please find the page32-03~32-06.

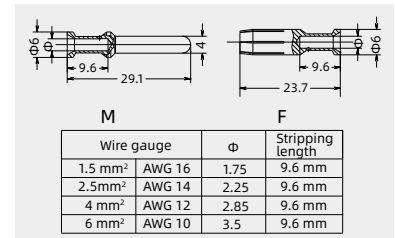
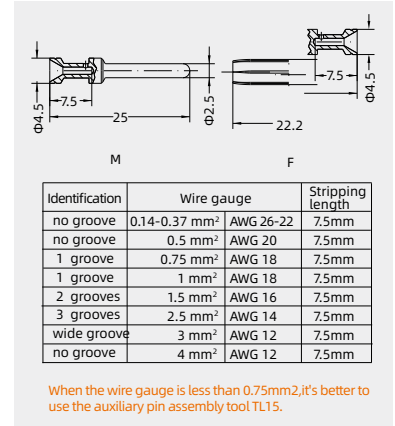
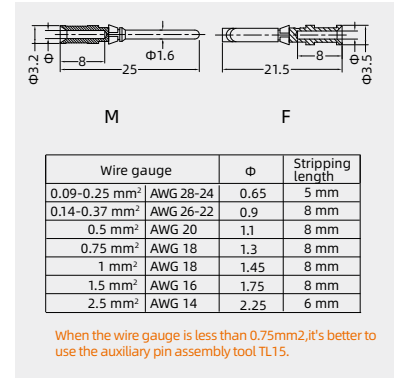
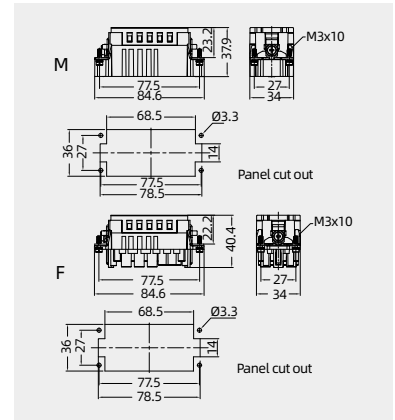

HK-032/55 Combination inserts



Technical characteristics

Specifications	DIN EN 60 664 DIN EN 61 984
Approvals	
Inserts	
Number of contacts	32/55
Electrical data acc. to EN 61 984	
Signal area	
Rated current	4A
Rated voltage	50V
Rated impulse voltage	0.8kV
Pollution degree	2
Power area	
Rated current	10A
Rated voltage	250V
Rated impulse voltage	4kV
Pollution degree	2
Rated voltage acc. to UL	600V
Insulation resistance	$\geq 10^{10}\Omega$
Material	polycarbonate
Limiting temperatures	-40°C ...+125°C
Flammability acc. to UL 94	V0
Mechanical working life(mating cycles)	≥ 500
Contacts	
Material	copper alloy
Surface	hard-silver plated hard-gold plated
Contact resistance	$\leq 3m\Omega$
Crimp terminal	
-mm ²	0.09-0.52mm ² /0.14-2.5mm ²
-AWG	28-20/26-14
Stripping length	5/8mm

HK-032/55 Combination inserts

250/50V 10/4A 32/55+ 



Inserts

Hoods/Housings: size 10B, please find the details on page 15-39~15-69.

Crimp terminal

order crimp contacts separately



Insert	Designation	Order No.
Male	HK-032/55-MC	128 087 010 0001
Female	HK-032/55-FC	128 087 020 0001

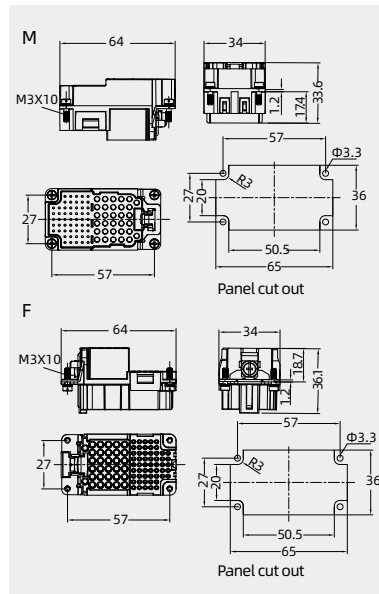

Crimp contacts

Crimp contacts 5A

Contact resistance $\leq 3m\Omega$
silver plated



gold plated



Male	Order No.	Female	Order No.
CSSM-0.25	101 014 110 0101	CSSF-0.25	101 014 120 0101
CSSM-0.33	101 014 110 0201	CSSF-0.33	101 014 120 0201
CSSM-0.52	101 014 110 0501	CSSF-0.52	101 014 120 0501
CSGM-0.25	101 014 210 0101	CSGF-0.25	101 014 220 0101
CSGM-0.33	101 014 210 0201	CSGF-0.33	101 014 220 0201
CSGM-0.52	101 014 210 0501	CSGF-0.52	101 014 220 0501

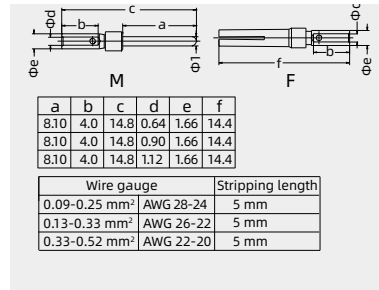

Crimp contacts 10A

Contact resistance $\leq 3m\Omega$
silver plated



gold plated



Male	Order No.	Female	Order No.
CDSM-0.25	101 017 110 0101	CDSF-0.25	101 017 120 0101
CDSM-0.37	101 017 110 0301	CDSF-0.37	101 017 120 0301
CDSM-0.50	101 017 110 0401	CDSF-0.50	101 017 120 0401
CDSM-0.75	101 017 110 0601	CDSF-0.75	101 017 120 0601
CDSM-1.0	101 017 110 0801	CDSF-1.0	101 017 120 0801
CDSM-1.5	101 017 110 0901	CDSF-1.5	101 017 120 0901
CDSM-2.5	101 017 110 1001	CDSF-2.5	101 017 120 1001
CDGM-0.25	101 017 210 0101	CDGF-0.25	101 017 220 0101
CDGM-0.37	101 017 210 0301	CDGF-0.37	101 017 220 0301
CDGM-0.50	101 017 210 0401	CDGF-0.50	101 017 220 0401
CDGM-0.75	101 017 210 0601	CDGF-0.75	101 017 220 0601
CDGM-1.0	101 017 210 0801	CDGF-1.0	101 017 220 0801
CDGM-1.5	101 017 210 0901	CDGF-1.5	101 017 220 0901
CDGM-2.5	101 017 210 1001	CDGF-2.5	101 017 220 1001

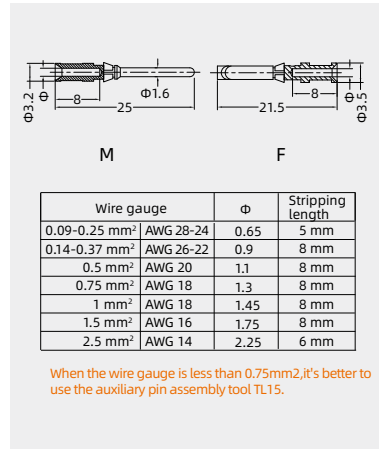

More crimp contacts 10A
see P13-02, P13-03.

Tools

Crimping tool



Wire gauge	Designation	Order No.
0.09-0.82mm ²	TL03	198 001 001 0002

Contact removal tool



Application	Designation	Order No.
for 5A crimp contact	TL08	198 001 000 0006

Tools

Crimping tool



Wire gauge	Designation	Order No.
0.14-4mm ²	TL02G	198 001 001 0011

Contact removal tool



Application	Designation	Order No.
for 10A crimp contact	TL00	198 001 000 0001

Notes: The tools for crimp terminal may influence the product quality and stability. Please select the tools recognized by our company.

More tools detail please find the page 32-03~32-06.

HK-009/12/25 Combination inserts



Technical characteristics

Specifications	DIN EN 60 664 DIN EN 61 984
Approvals	RU .RU
Inserts	
Number of contacts	9/12/25
Electrical data acc. to EN 61 984	
Signal area	
Rated current	5A
Rated voltage	50V
Rated impulse voltage	0.8kV
Pollution degree	3
Power area	
Rated current	10A/40A
Rated voltage	250V/630V
Rated impulse voltage	4kV/8kV
Pollution degree	3
Insulation resistance	$\geq 10^{10}\Omega$
Material	polycarbonate
Limiting temperatures	-40°C ...+125°C
Flammability acc. to UL 94	V0
Mechanical working life(mating cycles)	≥ 500
Contacts	
Material	copper alloy
Surface	hard-silver plated hard-gold plated
Contact resistance	$\leq 3m\Omega/1m\Omega$
Crimp terminal	
-mm ²	0.09-0.52mm ² /0.14-2.5mm ² / 1.5-6mm ²
-AWG	28-20/26-14/16-10
Stripping length	5/8/9(9.6)mm

HK-009/12/25 Combination inserts

630/250/50V 40/10/5A 009/12/25+



Inserts

Hoods/Housings: size 16B, please find the details on page 15-70~15-1071.

Crimp terminal

order crimp contacts separately



Insert	Designation	Order No.
Male	HK-009/12/25-MC	128 009 010 0002
Female	HK-009/12/25-FC	128 009 020 0002

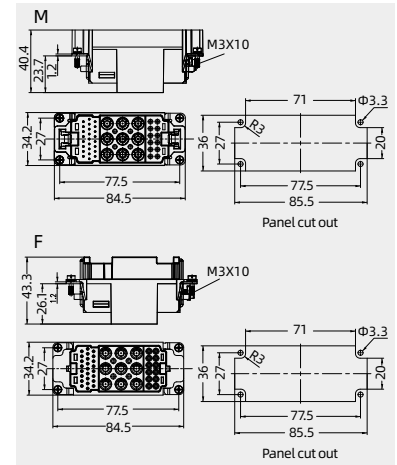

Crimp contacts

Crimp contacts 5A

Contact resistance $\leq 3m\Omega$
silver plated



Male	Order No.	Female	Order No.
CSSM-0.25	101 014 110 0101	CSSF-0.25	101 014 120 0101
CSSM-0.33	101 014 110 0201	CSSF-0.33	101 014 120 0201
CSSM-0.52	101 014 110 0501	CSSF-0.52	101 014 120 0501
CSGM-0.25	101 014 210 0101	CSGF-0.25	101 014 220 0101
CSGM-0.33	101 014 210 0201	CSGF-0.33	101 014 220 0201
CSGM-0.52	101 014 210 0501	CSGF-0.52	101 014 220 0501

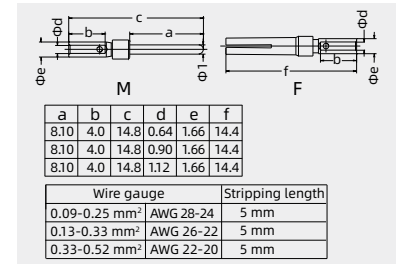

Crimp contacts 10A

Contact resistance $\leq 3m\Omega$
silver plated



Male	Order No.	Female	Order No.
CDSM-0.25	101 017 110 0101	CDSF-0.25	101 017 120 0101
CDSM-0.37	101 017 110 0301	CDSF-0.37	101 017 120 0301
CDSM-0.50	101 017 110 0401	CDSF-0.50	101 017 120 0401
CDSM-0.75	101 017 110 0601	CDSF-0.75	101 017 120 0601
CDSM-1.0	101 017 110 0801	CDSF-1.0	101 017 120 0801
CDSM-1.5	101 017 110 0901	CDSF-1.5	101 017 120 0901
CDSM-2.5	101 017 110 1001	CDSF-2.5	101 017 120 1001
CDGM-0.25	101 017 210 0101	CDGF-0.25	101 017 220 0101
CDGM-0.37	101 017 210 0301	CDGF-0.37	101 017 220 0301
CDGM-0.50	101 017 210 0401	CDGF-0.50	101 017 220 0401
CDGM-0.75	101 017 210 0601	CDGF-0.75	101 017 220 0601
CDGM-1.0	101 017 210 0801	CDGF-1.0	101 017 220 0801
CDGM-1.5	101 017 210 0901	CDGF-1.5	101 017 220 0901
CDGM-2.5	101 017 210 1001	CDGF-2.5	101 017 220 1001

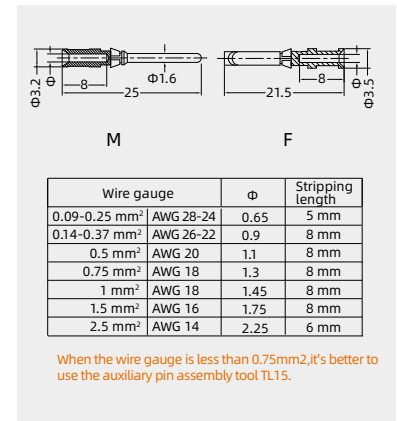

More crimp contacts 10A
see P13-02,P13-03.

Crimp contacts 40A

silver plated

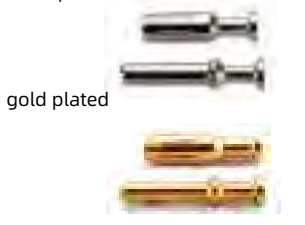

Male	Order No.	Female	Order No.
CCSM-1.5	101 023 110 0901	CCSF-1.5	101 023 120 0901
CCSM-2.5	101 023 110 1001	CCSF-2.5	101 023 120 1001
CCSM-4.0	101 023 110 1201	CCSF-4.0	101 023 120 1201
CCSM-6.0	101 023 110 1301	CCSF-6.0	101 023 120 1301
CCGM-1.5	101 023 210 0901	CCGF-1.5	101 023 220 0901
CCGM-2.5	101 023 210 1001	CCGF-2.5	101 023 220 1001
CCGM-4.0	101 023 210 1201	CCGF-4.0	101 023 220 1201
CCGM-6.0	101 023 210 1301	CCGF-6.0	101 023 220 1301

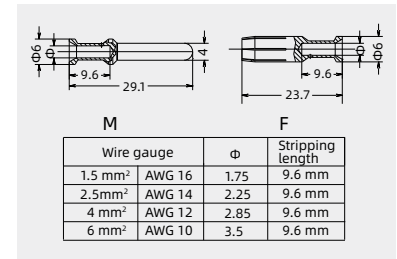

Tools

Crimping tool



Wire gauge	Designation	Order No.
0.09-0.82mm ²	TL03	198 001 001 0002
0.14-4mm ²	TL02G	198 001 001 0011
1.5-6mm ²	TL02-0G	198 001 001 0012

Tools

Contact removal tool



Wire gauge	Designation	Order No.
for 5A crimp contact	TL08	198 001 000 0006
for 10A crimp contact	TL00	198 001 000 0001
for 40A crimp contact	TL06G	198 001 000 0009

Notes: The tools for crimp terminal may influence the product quality and stability.
Please select the tools recognized by our company. More tools detail please find the page 32-03-32-06.

HY-004/RJ45 Combination inserts



Technical characteristics

Specifications	DIN EN 60 664 DIN EN 61 984
Approvals	
Inserts	
Electrical data acc. to EN 61 984	
Power area	
Number of contacts	4+PE
Rated current	16A
Rated voltage	240V
Rated impulse voltage	4kV
Pollution degree	3
Insulation resistance	$\geq 10^{10}\Omega$
Material	polycarbonate
Color	RAL 7032 (Light grey)
Limiting temperatures	-40°C - +85°C
Signal area	
Number of contacts	8
Rated current	1A
-Rated voltage	50V
-Rated impulse voltage	0.8kV
-Pollution degree	3
Insulation resistance	$\geq 10^{10}\Omega$
Material	polycarbonate
Limiting temperatures	-40°C ...+85°C
Flammability acc. to UL 94	V0
Mechanical working life(mating cycles)	≥ 500
Transmission characteristics:	over 6 type jumper up to 500MHz According to ISO/IEC 24 702; ISO/IEC 11 801
Transmission rate:	10/100/1000Mbit/10Gbit/s
Contacts	
Material	copper alloy
Surface	hard-silver plated hard-gold plated
Contact resistance	$\leq 1m\Omega$
Crimp terminal	
-mm ²	0.37-4mm ²
-AWG	22-12

HY-004/RJ45 Combination inserts

240/50V 16/1A 4+ 

Inserts

Crimp terminal
order crimp contacts separately



Insert	Designation	Order No.
Male	HY-004/RJ45-MC	138 004 010 0001
Female	HY-004/RJ45-FC	138 004 020 0001

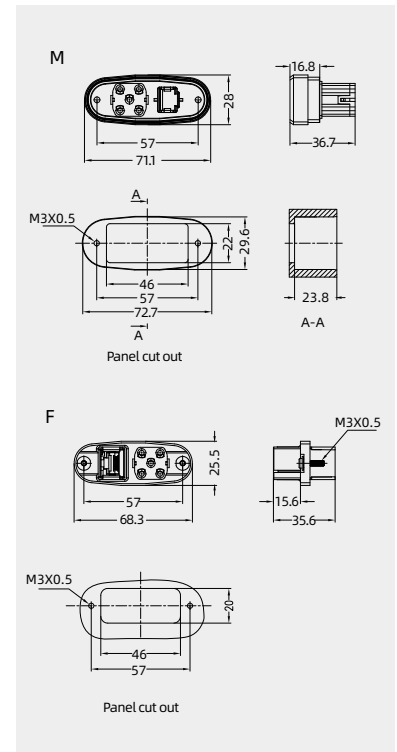

Crimp contacts

Crimp contacts 16A

Contact resistance $\leq 1m\Omega$
silver plated



gold plated



More crimp contacts 16A see P13-04.

Male	Order No.	Female	Order No.
CESM-0.37	101 019 110 0301	CESF-0.37	101 019 120 0301
CESM-0.50	101 019 110 0401	CESF-0.50	101 019 120 0401
CESM-0.75	101 019 110 0601	CESF-0.75	101 019 120 0601
CESM-1.0	101 019 110 0801	CESF-1.0	101 019 120 0801
CESM-1.5	101 019 110 0901	CESF-1.5	101 019 120 0901
CESM-2.5	101 019 110 1001	CESF-2.5	101 019 120 1001
CESM-3.0	101 019 110 1101	CESF-3.0	101 019 120 1101
CESM-4.0	101 019 110 1201	CESF-4.0	101 019 120 1201
CEGM-0.37	101 019 210 0301	CEGF-0.37	101 019 220 0301
CEGM-0.50	101 019 210 0401	CEGF-0.50	101 019 220 0401
CEGM-0.75	101 019 210 0601	CEGF-0.75	101 019 220 0601
CEGM-1.0	101 019 210 0801	CEGF-1.0	101 019 220 0801
CEGM-1.5	101 019 210 0901	CEGF-1.5	101 019 220 0901
CEGM-2.5	101 019 210 1001	CEGF-2.5	101 019 220 1001
CEGM-3.0	101 019 210 1101	CEGF-3.0	101 019 220 1101
CEGM-4.0	101 019 210 1201	CEGF-4.0	101 019 220 1201

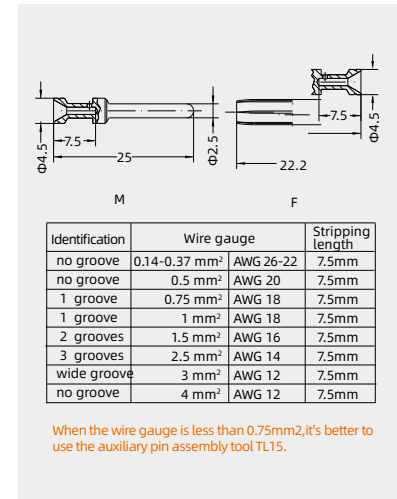

Tools



Wire gauge	Designation	Order No.
0.14-4mm ²	TL02G	198 001 001 0011
Wire gauge: 0.14-0.37mm ² please select TL02 Crimping tool.		
Application	Designation	Order No.
for crimp contacts 16A	TL01	198 001 000 0002

More tools detail please find the page 32-03~32-06.

Notes: The tools for crimp terminal may influence the product quality and stability. Please select the tools recognized by our company.

HE AV SERIES

Extendible connector

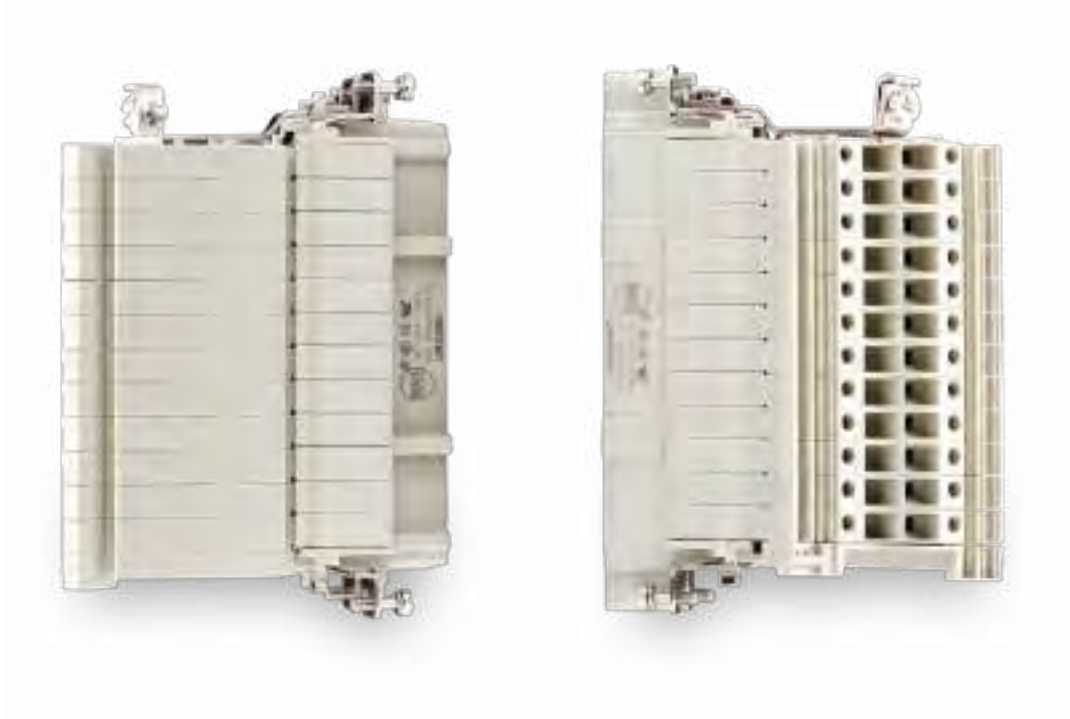

HE AV SERIES Extendible inserts

Technical characteristics

Specifications	DIN EN 60 664 DIN EN 61 984
Approvals	
Inserts	
Number of contacts	6,10,16,24+PE
Electrical data acc. to EN 61 984	
-Rated current	16A
-Rated voltage	500V
-Rated impulse voltage	6kV
-Pollution degree	3
-Pollution degree 2 also	16A 400/690V 6kV 2
Rated voltage acc. to UL	600V
Insulation resistance	$\geq 10^{10}\Omega$
Material	polycarbonate
Limiting temperatures	-40°C ...+125°C
Flammability acc. to UL 94	V0
Mechanical working life(mating cycles)	≥ 500
Contacts	
Material	copper alloy
Surface	hard-silver plated tin plated
Contact resistance	$\leq 4m\Omega$
Screw terminal	
- Wire gauge	0.2-2.5mm ²
- AWG	24-14
- Tightening/test torque	0.5Nm

Current carrying capacity

The current carrying is limited by maximum temperature of materials for inserts and contacts including terminals

Control and test procedures according to DIN EN 60512-5

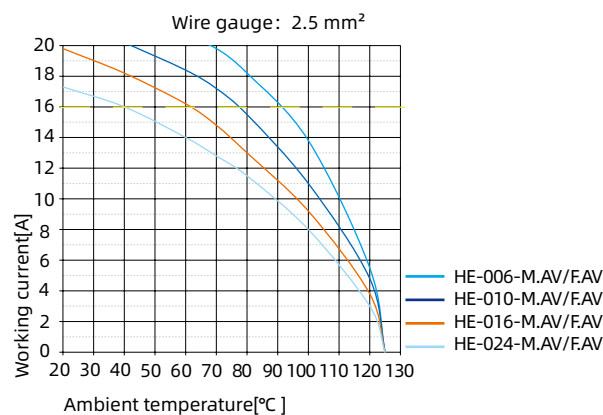
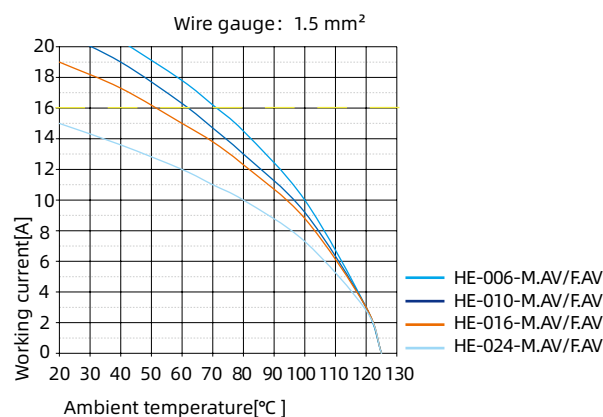

HE AV Extendible inserts

500V 16A 6+ ⊕

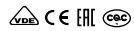

Hoods/Housings: size 6B bulkhead mounted housings.
For the HEAV extendible inserts assembly instructions pls see the 09-13 page

Inserts

Male, Screw terminal



Size	Description	Designation	Order No.
6B	left hand version	HE-006-M.AV.L	122 006 011 0101
6B	right hand version	HE-006-M.AV.R	122 006 011 0102

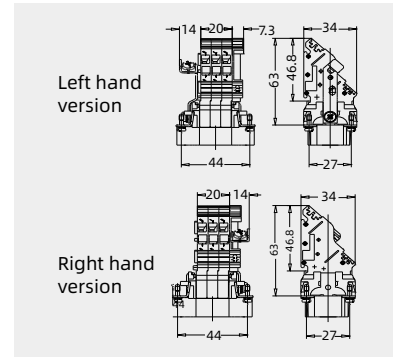

Female, Screw terminal



Size	Description	Designation	Order No.
6B	left hand version	HE-006-F.AV.L	122 006 021 0101
6B	right hand version	HE-006-F.AV.R	122 006 021 0102

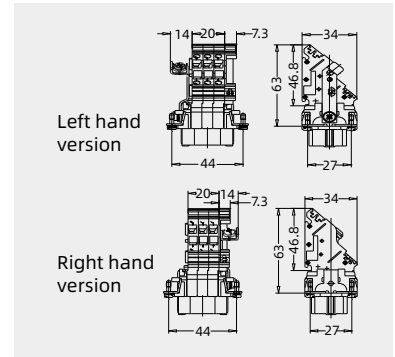

Male, Quick-in



Size	Description	Designation	Order No.
6B	left hand version	HE-006-MQ.AV.L	122 006 001 0001
6B	right hand version	HE-006-MQ.AV.R	122 006 001 0002

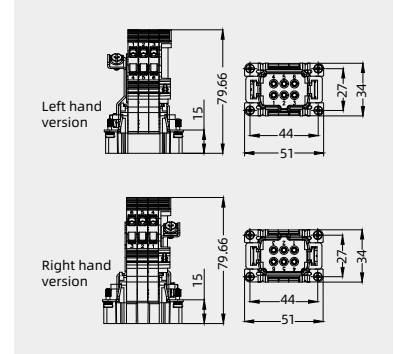

Female, Quick-in



Size	Description	Designation	Order No.
6B	left hand version	HE-006-FQ.AV.L	122 006 002 0001
6B	right hand version	HE-006-FQ.AV.R	122 006 002 0002

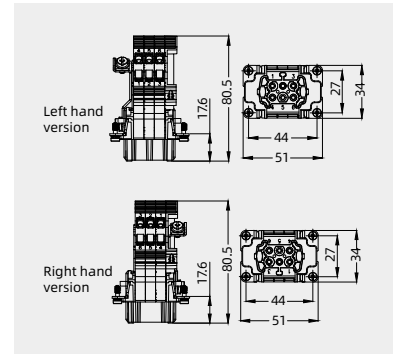

HE AV Extendible inserts

500V 16A 10+ 



Inserts

Hoods/Housings: size 10B bulkhead mounted housings.
For the HEAV extendible inserts assembly instructions pls see the 09-13 page

Male, Screw terminal

Size	Description	Designation	Order No.
10B	left hand version	HE-010-M.AV.L	122 010 011 0101
10B	right hand version	HE-010-M.AV.R	122 010 011 0102

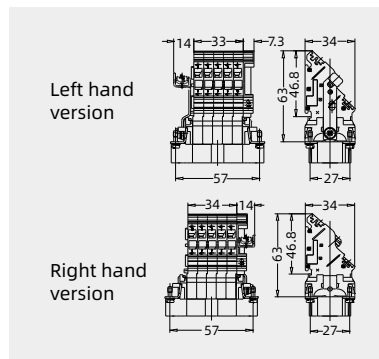

Female, Screw terminal

Size	Description	Designation	Order No.
10B	left hand version	HE-010-F.AV.L	122 010 021 0101
10B	right hand version	HE-010-F.AV.R	122 010 021 0102

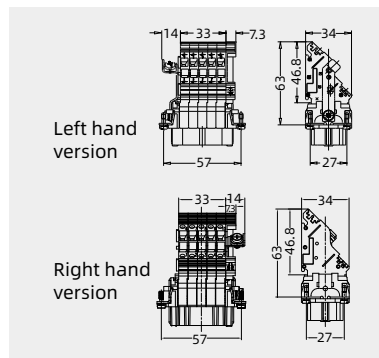

Male, Quick-in

Size	Description	Designation	Order No.
10B	left hand version	HE-010-MQ.AV.L	122 010 001 0001
10B	right hand version	HE-010-MQ.AV.R	122 010 001 0002

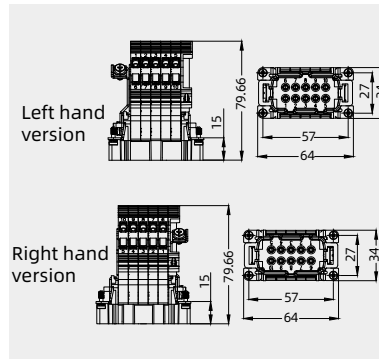

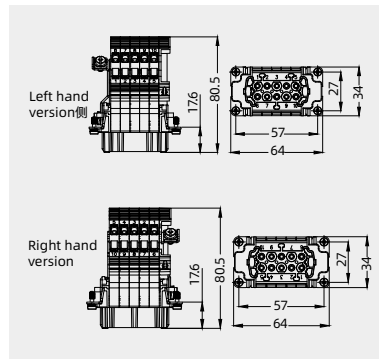

Female, Quick-in

Size	Description	Designation	Order No.
10B	left hand version	HE-010-FQ.AV.L	122 010 002 0001
10B	right hand version	HE-010-FQ.AV.R	122 010 002 0002

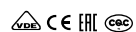

HE AV Extendible inserts

500V 16A 16+ 

Inserts

Hoods/Housings: size 16B bulkhead mounted housings.

For the HEAV extendible inserts assembly instructions pls see the 09-13 page

Male, Screw terminal



Size	Description	Designation	Order No.
16B	left hand version	HE-016-M.AV.L	122 016 011 0101
16B	right hand version	HE-016-M.AV.R	122 016 011 0102

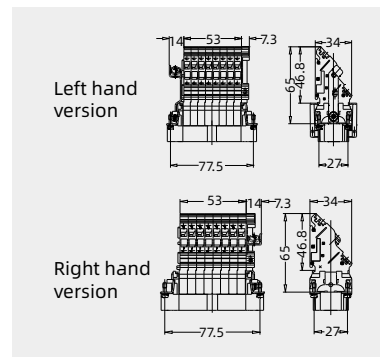

Female, Screw terminal



Size	Description	Designation	Order No.
16B	left hand version	HE-016-F.AV.L	122 016 021 0101
16B	right hand version	HE-016-F.AV.R	122 016 021 0102

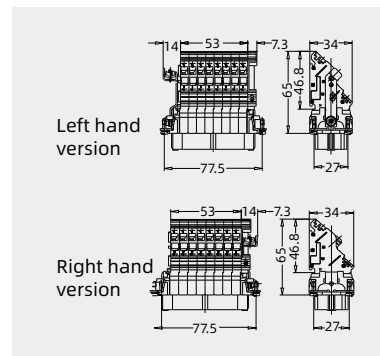

Male, Quick-in



Size	Description	Designation	Order No.
16B	left hand version	HE-016-MQ.AV.L	122 016 001 0001
16B	right hand version	HE-016-MQ.AV.R	122 016 001 0002

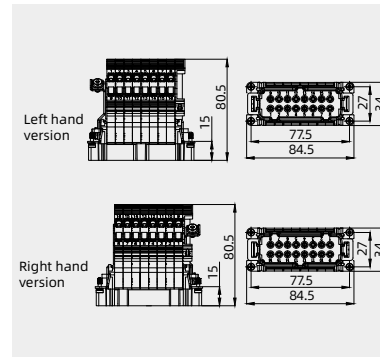



Female, Quick-in

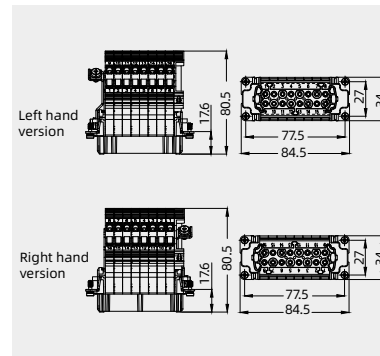

Size	Description	Designation	Order No.
16B	left hand version	HE-016-FQ.AV.L	122 016 002 0001
16B	right hand version	HE-016-FQ.AV.R	122 016 002 0002

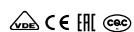

HE AV Extendible inserts

500V 16A 24+ 

Inserts

Hoods/Housings: size 24B bulkhead mounted housings.
For the HEAV extendible inserts assembly instructions pls see the 09-13 page

Male, Screw terminal



Size	Description	Designation	Order No.
24B	left hand version	HE-024-M.AV.L	122 024 011 0101
24B	right hand version	HE-024-M.AV.R	122 024 011 0102

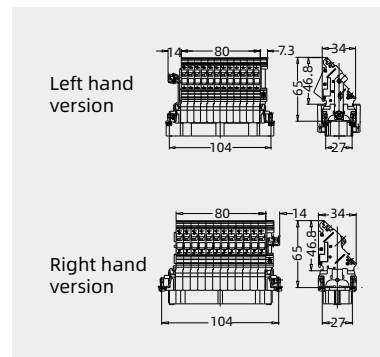

Female, Screw terminal



Size	Description	Designation	Order No.
24B	left hand version	HE-024-F.AV.L	122 024 021 0101
24B	right hand version	HE-024-F.AV.R	122 024 021 0102

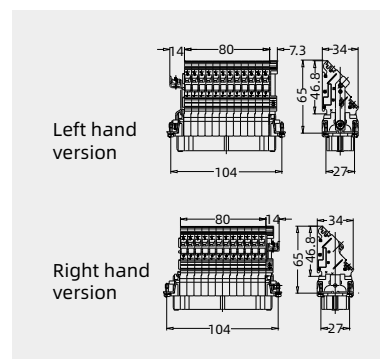

Male, Quick-in



Size	Description	Designation	Order No.
24B	left hand version	HE-024-MQ.AV.L	122 024 001 0001
24B	right hand version	HE-024-MQ.AV.R	122 024 001 0002

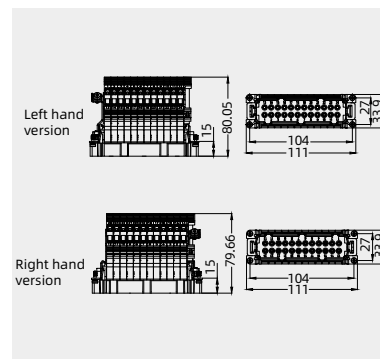

Female, Quick-in



Size	Description	Designation	Order No.
24B	left hand version	HE-024-FQ.AV.L	122 024 002 0001
24B	right hand version	HE-024-FQ.AV.R	122 024 002 0002

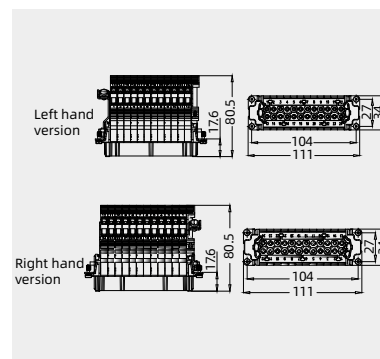

Using the fixing element can secure the HE AV insert inside the switch cabinet on standard rails.

Fixing element



Description	Designation	Order No.
for terminal block connector	FE-EAV	198 002 003 0022

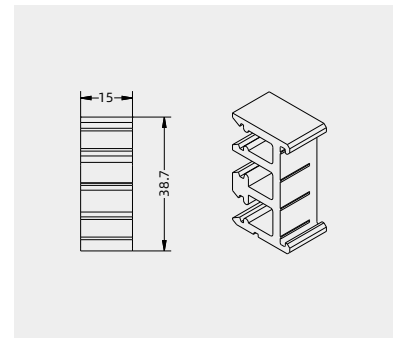

Examples for Installstion

Introductions

HE-006 =1pcs
HE-010,HE-016,HE-024 =2pcs

HD AV SERIES

Extendible connector



HD AV SERIES

Technical characteristics

Specifications	DIN EN 60 664 DIN EN 61 984
Approvals	EN
Inserts	
Number of contacts	40,64+PE
Electrical data acc. to EN 61 984	
-Rated current	10A
-Rated voltage	250V
-Rated impulse voltage	4kV
-Pollution degree	3
-Pollution degree 2 also	10A 230/400V 4kV 2
Rated voltage acc. to UL	600V
Insulation resistance	$\geq 10^{10}\Omega$
Material	polycarbonate
Limiting temperatures	-40°C ...+125°C
Flammability acc. to UL 94	V0
Mechanical working life(mating cycles)	≥ 500
Contacts	
Material	copper alloy
Surface	
- mating side	hard-silver plated
- termination side	tin plated
Contact resistance	$\leq 10m\Omega$
Screw terminal	
- Wire gauge	0.2-2.5mm ²
- AWG	24-14
- Tightening/test torque	0.5Nm

Current carrying capacity

The current carrying is limited by maximum temperature of materials for inserts and contacts including terminals

Control and test procedures according to DIN EN 60512-5

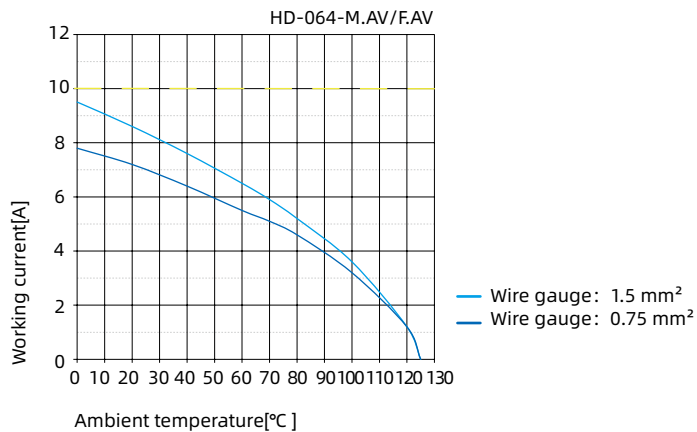
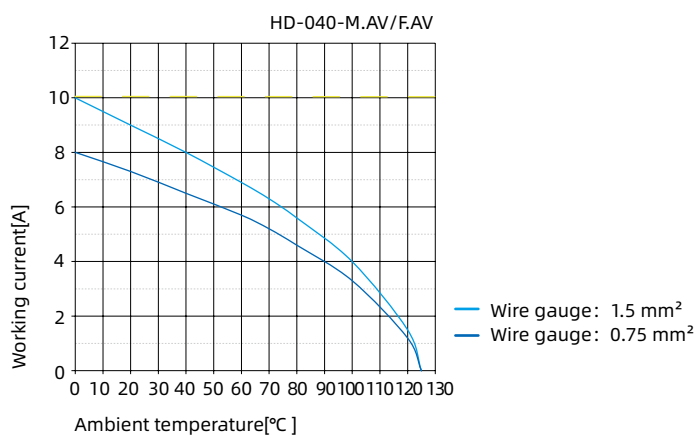

HD AV Extendible inserts

250V 10A 40+ 

EAC

Inserts

Hoods/Housings: size 16B bulkhead mounted housings.
For the HDAV extendible inserts assembly instructions pls see the 09-13 page

Male, Screw terminal



Size	Description	Designation	Order No.
16B	left hand version	HD-040-M.AV.L	125 040 011 0101
16B	right hand version	HD-040-M.AV.R	125 040 011 0102

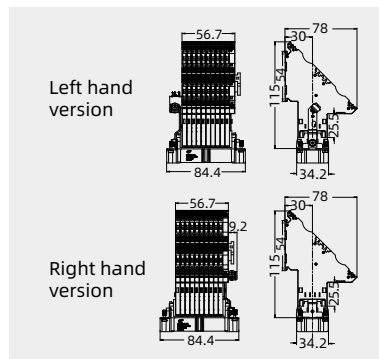

Female, Screw terminal



Size	Description	Designation	Order No.
16B	left hand version	HD-040-F.AV.L	125 040 021 0101
16B	right hand version	HD-040-F.AV.R	125 040 021 0102

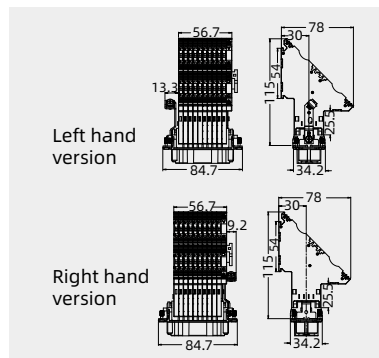

HD AV Extendible inserts

250V 10A 64+ 

EH

Inserts

Hoods/Housings: size 24B bulkhead mounted housings.
For the HDAV extendible inserts assembly instructions pls see the 09-13 page

Male, Screw terminal



Size	Description	Designation	Order No.
24B	left hand version	HD-064-M.AV.L	125 064 011 0101
24B	right hand version	HD-064-M.AV.R	125 064 011 0102

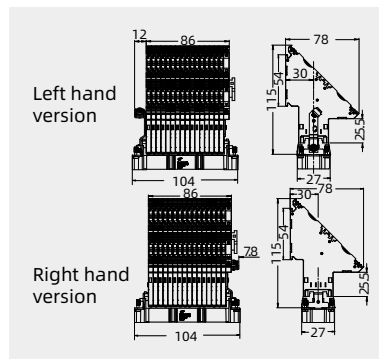

Female, Screw terminal



Size	Description	Designation	Order No.
24B	left hand version	HD-064-F.AV.L	125 064 021 0101
24B	right hand version	HD-064-F.AV.R	125 064 021 0102

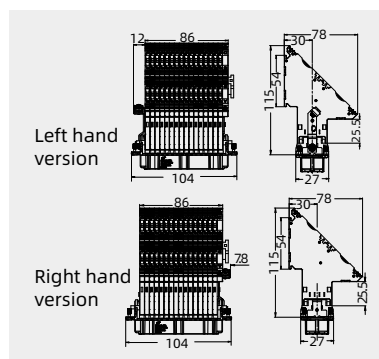

Using the fixing element can secure the HD AV insert inside the switch cabinet on standard rails.

Fixing element



Description	Designation	Order No.
for terminal block connector	FE-DAV	198 002 003 0034

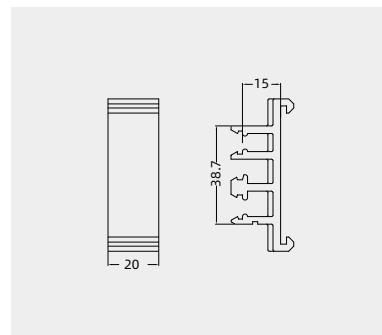

Examples for Installation

Introductions

HD-040, HD-064 =2pcs

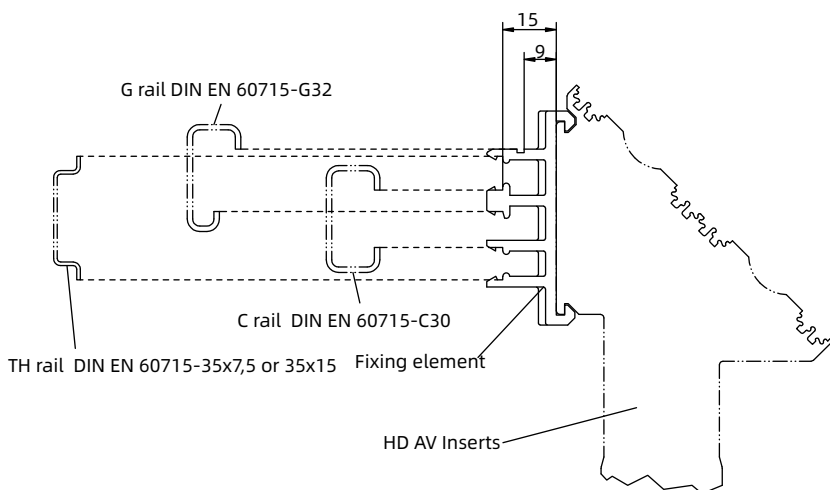

HE AV/HD AV Assembly

HE AV Assembly

Possibilities in switch cabinet

The connector can be mounted in the switch cabinet on the left or right side, therefore it is allowed to use the same prepared interface cable.

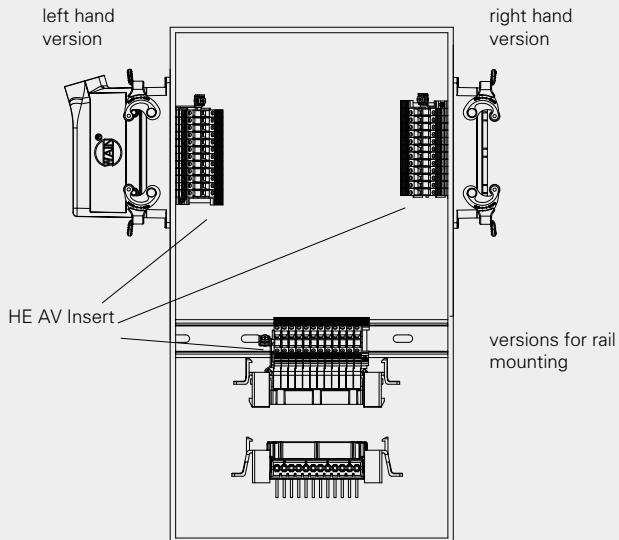

Assembly of terminal block connectors

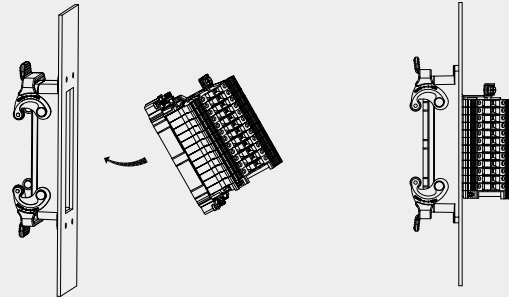

Method I: installed on standard 24B bulkhead housings

Install the insert on the housing from the inside of the cabinet with a 45° angle, and the ground connection must be installed first. After the insert is completely installed in the housing, lock the insert with four grounding screws.

HD AV Assembly

Possibilities in switch cabinet

The connector can be mounted in the switch cabinet on the left or right side, therefore it is allowed to use the same prepared interface cable.

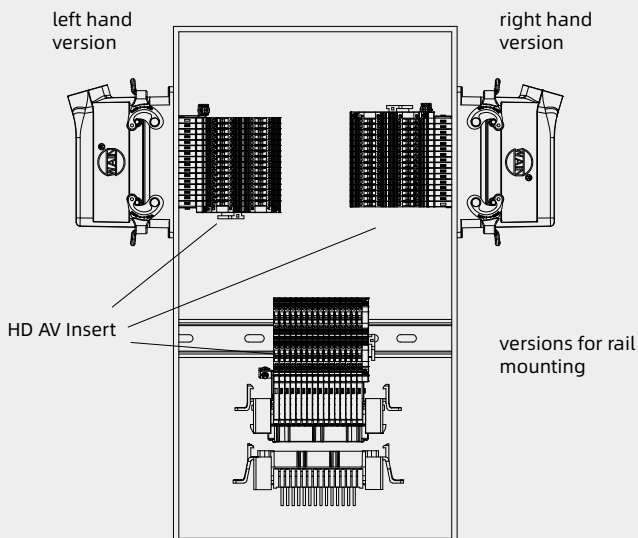

Assembly of terminal block connectors

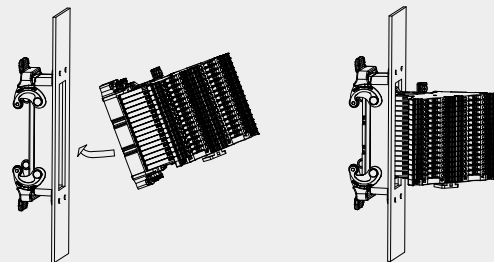

Method I: installed on standard 24B bulkhead housings

Install the insert on the housing from the inside of the cabinet with a 45° angle, and the ground connection must be installed first. After the insert is completely installed in the housing, lock the insert with four grounding screws.

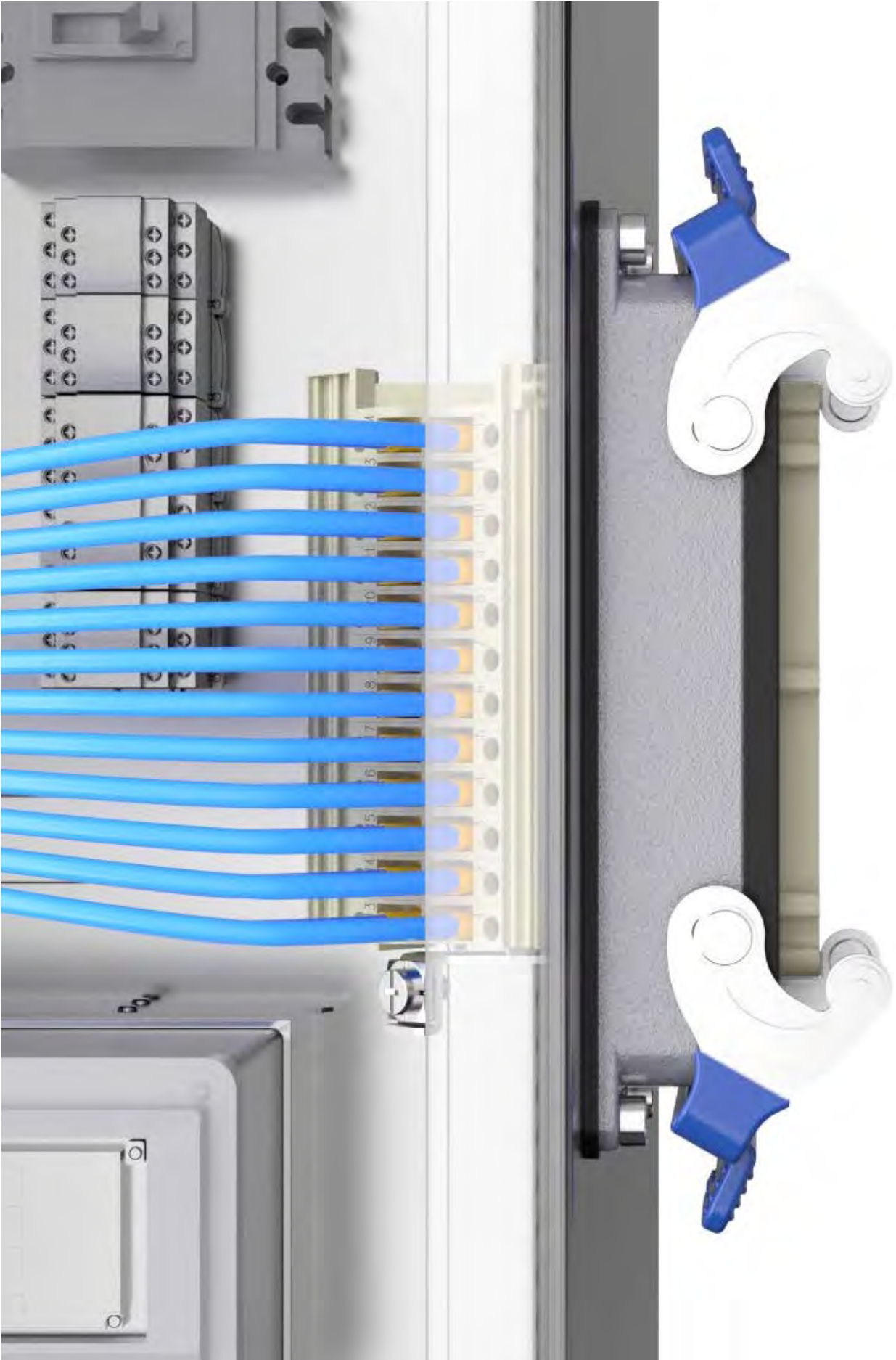





HM SERIES

Flexible and combined connector







Summary



Insert	200A Axial module	200A Axial grounding module	200A Crimp module	100A Crimp module
Contacts	1	1	1	1
Terminal	Axial screw terminal	Axial screw terminal	Crimp terminal	Crimp terminal
				
Rated current	200A	200A	200A	100A
Rated voltage	1000V	1000V	1000V	830V
Wire gauge	25-70mm ²	25-70mm ²	25-70mm ²	10-35mm ²





Insert	100A Axial module	100A Crimp module	70A Axial module	70A Crimp module
Contacts	2	2	2	2
Terminal	Axial screw terminal	Crimp terminal	Axial screw terminal	Crimp terminal
				
Rated current	100A	100A	70A	70A
Rated voltage	1000V	1000V	1000V	1000V
Wire gauge	10-35mm ²	10-35mm ²	6-22mm ²	10-25mm ²



Insert	40A Axial module	40A Crimp module	40A Axial module	40A Crimp module
Contacts	2	2	3	3
Terminal	Axial screw terminal	Crimp terminal	Axial screw terminal	Crimp terminal
				
Rated current	40A	40A	40A	40A
Rated voltage	1000V	1000V	690V	500V
Wire gauge	2.5-10mm ²	1.5-10mm ²	2.5-10mm ²	1.5-10mm ²

Insert	40A Crimp module	40/10A Crimp module	40A Crimp module	40A High voltage module
Contacts	3	3/4	4	2
Terminal	Crimp terminal	Crimp terminal	Crimp terminal	Crimp terminal
				
Rated current	40A	40A/10A	40A	40A
Rated voltage	690V	830V	830V	2900/5000V
Wire gauge	1.5-6mm ²	1.5-6mm ² /0.37-2.5mm ²	1.5-6mm ²	1.5-10mm ²

Summary

Insert	16A High voltage module	16A Screw module	16A Cage-clamp module	16A Crimp module
Contacts	2	5	5	6
Terminal	Crimp terminal	Screw terminal	Cage clamp terminal	Crimp terminal
				
Rated current	16A	16A	16A	16A
Rated voltage	2900/5000V	230/400V	400V	500V
Wire gauge	0.37-4mm ²	0.14-4mm ²	0.14-2.5mm ²	0.14-4mm ²

Insert	16A Spring module	16A Protected module	16A Crimp module	16A Spring module
Contacts	6	6	8	8
Terminal	spring terminal(Quick-in)	Crimp terminal	Crimp terminal	spring terminal(Quick-in)
				
Rated current	16A	16A	16A	16A
Rated voltage	500V	830V	400V	400V
Wire gauge	0.5-4mm ²	0.14-4mm ²	0.14-4mm ²	0.5-4mm ²

Insert	16A Crimp module	10A Crimp module	10A Spring module	
Contacts	20	12	12	
Terminal	Crimp terminal	Crimp terminal	spring terminal(Quick-in)	
				
Rated current	16A	10A	10A	
Rated voltage	500V	250V	250V	
Wire gauge	0.14-4mm ²	0.14-2.5mm ²	0.5-2.5mm ²	

Summary









Insert	10A Crimp module	10A Crimp module	MegaBit Insert	GigaBit Insert
Contacts	17	42	2x4+Shielded	8+Shielded
Terminal	Crimp terminal	Crimp terminal	Crimp terminal	Crimp terminal
				
Rated current	10A	10A	10A	5A
Rated voltage	160V	150V	50V	50V
Wire gauge	0.14-2.5mm ²	0.14-2.5mm ²	0.14-2.5mm ²	0.09-0.82mm ²



Insert	Shielded module	Adapter module	Adapter module	Cable clamp
Contacts	24+Shielded	1	1	
Terminal	Crimp terminal	for MegaBit Insert and GigaBit Insert	for 24 pins shielded module	for 100M,1000M and 24 pins modules
				
Rated current	4A			
Rated voltage	32V			
Wire gauge	0.09-0.52mm ²			Clamping range:5-12mm

Insert	5A D-Sub module	5A D-Sub module	5A D-Sub module 2	4A High Density module
Contacts	9	9	9	25
Terminal	Crimp terminal	Crimp terminal	Crimp terminal	Crimp terminal
				
Rated current	5A	5A	5A	4A
Rated voltage	50V	50V	50V	50V
Wire gauge	0.09-0.82mm ²	0.09-0.82mm ²	0.09-0.82mm ²	0.09-0.52mm ²

Insert	4A High Density module	1A RJ45 module		
Contacts	36	8		
Terminal	Crimp terminal	Module for patch cable		
				
Rated current	4A	1A		
Rated voltage	50V	50V		
Wire gauge	0.09-0.52mm ²			

Summary

Insert	Pneumatic module	Pneumatic module	Pneumatic Module(Metal Contact)	Pneumatic Module(Metal Contact)
Contacts	2	3	3	3
				
Contacts	 $\Phi 6$ mm	 $\Phi 1.6$ mm $\Phi 3.0$ mm $\Phi 4.0$ mm	 $\Phi 3.0$ mm $\Phi 4.0$ mm $\Phi 6.0$ mm	 $\Phi 3.0$ mm $\Phi 4.0$ mm $\Phi 6.0$ mm

Insert	Electromagnetic screening module				Fiber module	
Contacts	2				4	
						
Contacts	Q-Coax 4+shielding	High Density Q-Coax 8+shielding	D Coax 1+shielding	E Coax 1+shielding	single: 9/125 μ m	multimode: 50/125 μ m or 62.5/125 μ m

Insert	SC Fiber	H3A RJ45	Electromagnetic screening module			
Contacts	4	8	1			
						
Contacts	single: 9/125 μ m multimode: 50/125 μ m or 62.5/125 μ m		Q-Coax 4+shielding	High Density Q-Coax 8+shielding	D Coax 1+shielding	E Coax 1+shielding

Hinged frames

Technical characteristics

Number of modules	2,3,4,6
PE contact(Wire gauge)	
- Power side	4-10mm ² 【Use PE-E16,expandable to 16mm ² ;(see page P10-20 for details). Only suitable for high structure hood or BK housing. 】 AWG 12-8
- Signal side	1-2.5mm ² 18-14
Material	zinc die-cast
Limiting temperatures	-40°C ...+125°C
Mechanical working life(mating cycles)	≥ 500

Frame construction version 1

Unit: mm

6B frame, size 6B hoods/housings



Application	Marking	Designation	Order No.
for 2 modules	A-B	HF6B-NUA3	129 006 000 1004
for 2 modules	a-b	HF6B-NLA3	129 006 000 1003

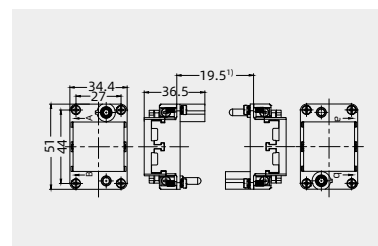

10B frame, size 10B hoods/housings



Application	Marking	Designation	Order No.
for 3 modules	A-C	HF10B-NUA3	129 010 000 1004
for 3 modules	a-c	HF10B-NLA3	129 010 000 1003

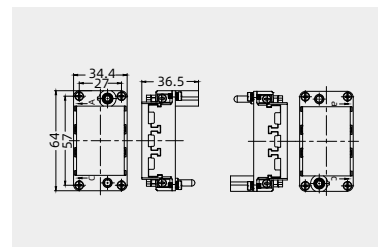

16B frame, size 16B hoods/housings



Application	Marking	Designation	Order No.
for 4 modules	A-D	HF16B-NUA3	129 016 000 1004
for 4 modules	a-d	HF16B-NLA3	129 016 000 1003

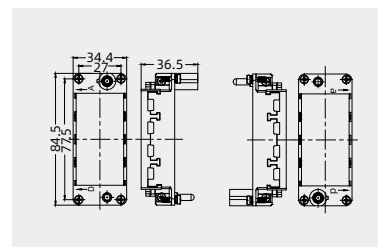

24B frame, size 24B hoods/housings



Application	Marking	Designation	Order No.
for 6 modules	A-F	HF24B-NUA3	129 024 000 1004
for 6 modules	a-f	HF24B-NLA3	129 024 000 1003

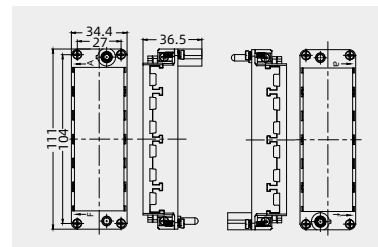

Hinged frames

Technical characteristics

Number of modules	2,3,4,6
PE contact(Wire gauge)	
- Power side	4-10mm ² 【Use PE-E16,expandable to 16mm ² ;Use PE-E25,expandable to 25mm ² ;(see page P10-20 for details). Only suitable for high structure hood or BK housing. 】 AWG 12-8
- Signal side	1-2.5mm ² 18-14
Material	zinc die-cast
Limiting temperatures	-40°C ...+125°C
Mechanical working life(mating cycles)	≥ 500

Frame construction version 2

Unit: mm

6B frame, size 6B hoods/housings



Application	Marking	Designation	Order No.
for 2 modules	A-B	HF6B-NUA2	129 006 000 1002
for 2 modules	a-b	HF6B-NLA2	129 006 000 1001

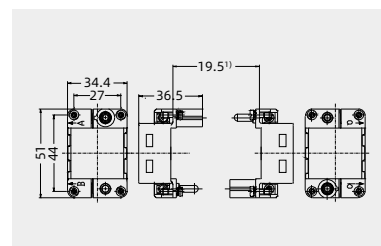

10B frame, size 10B hoods/housings



Application	Marking	Designation	Order No.
for 3 modules	A-C	HF10B-NUA2	129 010 000 1002
for 3 modules	a-c	HF10B-NLA2	129 010 000 1001

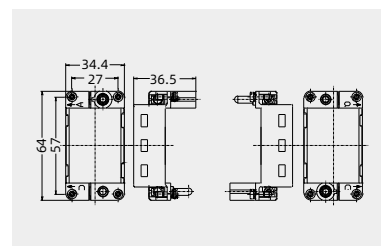

16B frame, size 16B hoods/housings



Application	Marking	Designation	Order No.
for 4 modules	A-D	HF16B-NUA2	129 016 000 1002
for 4 modules	a-d	HF16B-NLA2	129 016 000 1001

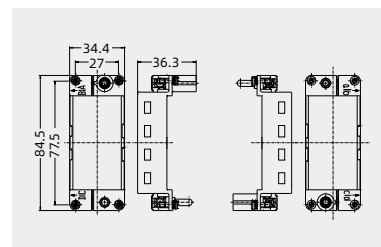

24B frame, size 24B hoods/housings



Application	Marking	Designation	Order No.
for 6 modules	A-F	HF24B-NUA2	129 024 000 1002
for 6 modules	a-f	HF24B-NLA2	129 024 000 1001

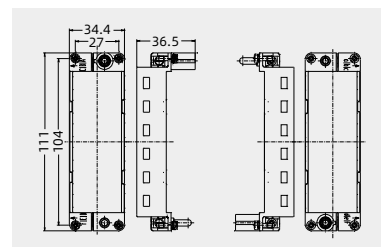

Locking element



Application	Designation	Order No.
Ideal topre-assemble the hinged frames	HF-LE2	198 002 003 0024

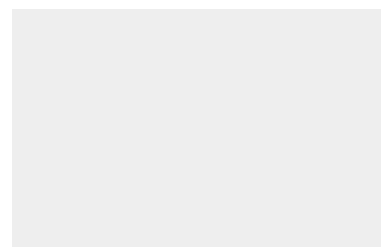

Metal Docking Frame

Technical characteristics



Number of modules	2+PE, 3+PE, 4+PE, 6+PE
Material	zinc die-cast
Limiting temperatures	-40°C ...+125°C
Mechanical working life(mating cycles)	≥ 500

单模块框架对接架

Unit: mm



Application	Marking	Designation	Order No.
for 1 modules	/	HF1M-MADK	198 002 004 0019
for 1 modules	/	HF1M-FADK	198 002 004 0020

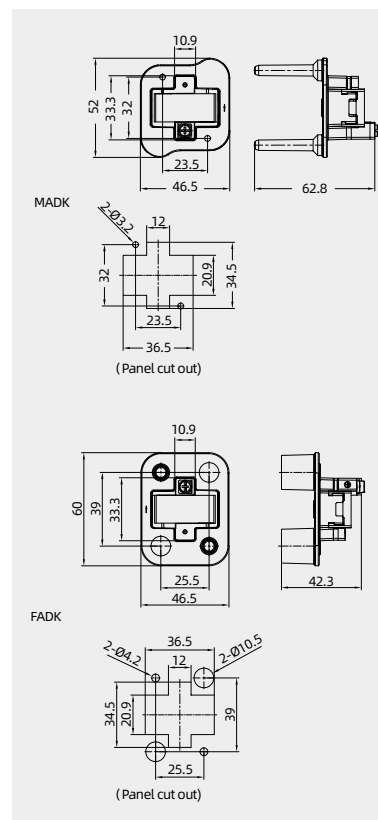

Floating washer

Floating washer



Describe	Designation	Order No.
Floating tolerance ±4	HF-ADK-D12	198 002 001 0004
Floating tolerance ±3	HF-ADK-D15	198 002 001 0003

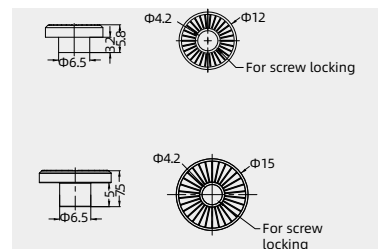

Metal Docking Frame

Technical characteristics

Number of modules	2+PE, 3+PE, 4+PE, 6+PE
Material	zinc die-cast
Limiting temperatures	-40°C ...+125°C
Mechanical working life(mating cycles)	≥ 500

Metal Docking Frame

Unit: mm

6B Metal Docking Frame

Application	Marking	Designation	Order No.
for 2 modules	A-B	HF6B-MADK	131 006 000 1006
for 2 modules	a-b	HF6B-FADK	131 006 000 1005

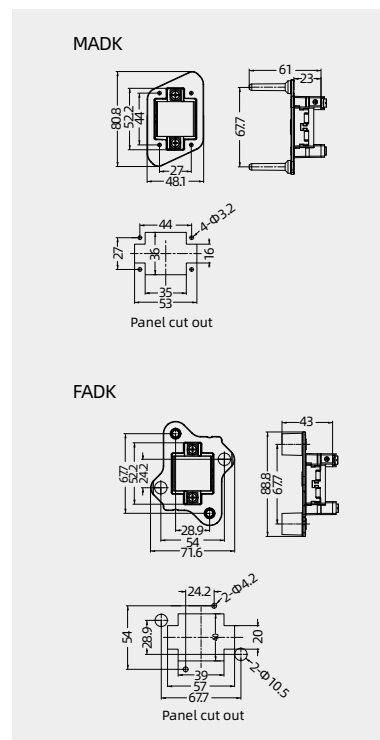

Floating washer

Floating washer

Describe	Designation	Order No.
Floating tolerance ±4	HF-ADK-D12	198 002 001 0004
Floating tolerance ±3	HF-ADK-D15	198 002 001 0003

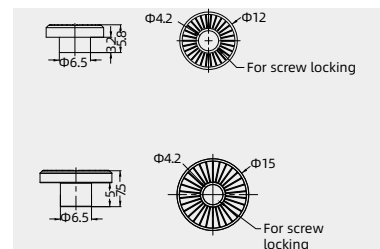

Metal Docking Frame

Technical characteristics

Number of modules	2+PE, 3+PE, 4+PE, 6+PE
Material	zinc die-cast
Limiting temperatures	-40°C ...+125°C
Mechanical working life(mating cycles)	≥ 500

Metal Docking Frame

Unit: mm

16B Metal Docking Frame

Application	Marking	Designation	Order No.
for 4 modules	A-D	HF16B-MADK	131 016 000 1005
for 4 modules	a-d	HF16B-FADK	131 016 000 1004

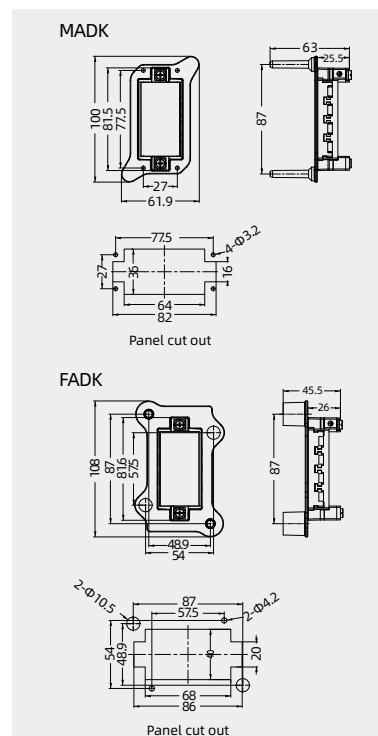

Floating washer

Floating washer

Describe	Designation	Order No.
Floating tolerance ± 4	HF-ADK-D12	198 002 001 0004
Floating tolerance ± 3	HF-ADK-D15	198 002 001 0003

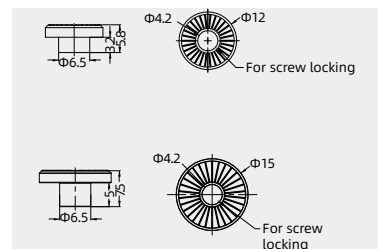

Metal Docking Frame

Technical characteristics

Number of modules	6+PE
Material	zinc die-cast
Limiting temperatures	-40°C ...+125°C
Mechanical working life(mating cycles)	≥ 500

Metal Docking Frame

Unit: mm

24B Metal Docking Frame

Application	Marking	Designation	Order No.
for 6 modules	A-F	HF24B-MADK	131 024 000 1004
for 6 modules	a-f	HF24B-FADK	131 024 000 1014

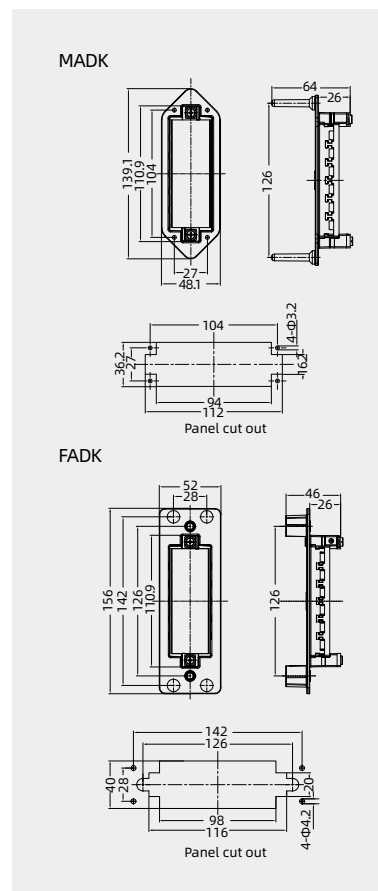

Floating washer

Floating washer

Describe	Designation	Order No.
Floating tolerance ±4	HF-ADK-D12	198 002 001 0004
Floating tolerance ±3	HF-ADK-D15	198 002 001 0003

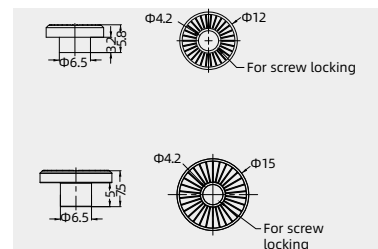

Plastic Docking Frame

Technical characteristics



Number of modules	3
Material	polycarbonate
Limiting temperatures	-40°C ...+125°C
Mechanical working life(mating cycles)	≥ 500
Floating tolerance	±2mm
Lock tolerance	±4mm

Plastic Docking Frame

Unit: mm

10B plastic docking frame



Application	Marking	Designation	Order No.
for 3 modules	A-C	HF10B.P-MADK	111 010 100 1501
for 3 modules	a-c	HF10B.P-FADK	111 010 100 1500

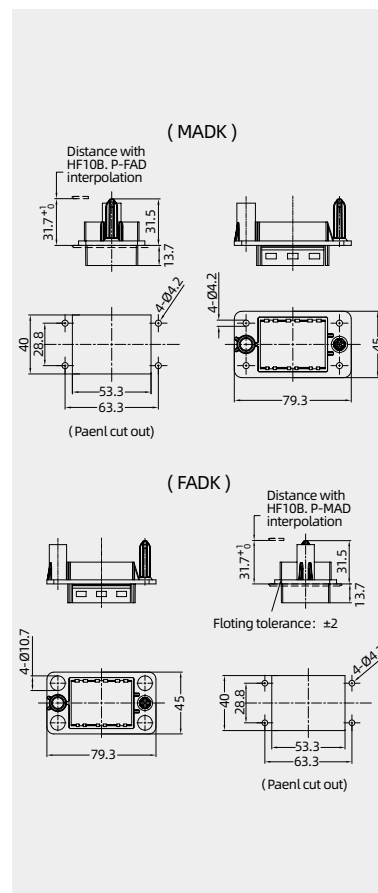

Floating washer

Floating washer



Describe	Designation	Order No.
Floating tolerance ±3	HF-ADK-D15	198 002 001 0003

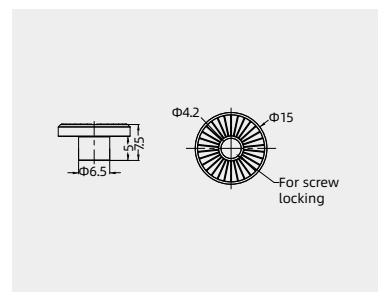

Plastic Docking Frame

Technical characteristics



Number of modules	3
Material	polycarbonate
Limiting temperatures	-40°C ...+125°C
Mechanical working life(mating cycles)	≥ 500
Floating tolerance	±2mm
Lock tolerance	±4mm

Plastic Docking Frame

Unit: mm

24B plastic docking frame



Application	Marking	Designation	Order No.
for 6 modules	A-F	HF24B.P-MADK	111 024 100 1501
for 6 modules	a-f	HF24B.P-FADK	111 024 100 1500

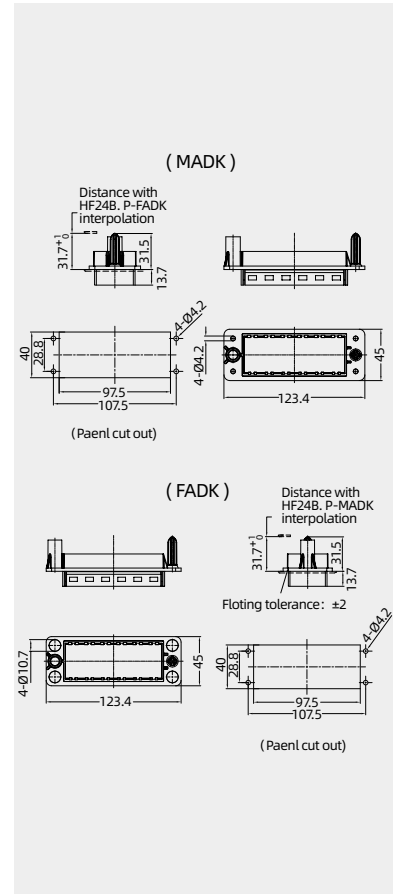

HM

Floating washer

Floating washer



Describe	Designation	Order No.
Floating tolerance±3	HF-ADK-D15	198 002 001 0003

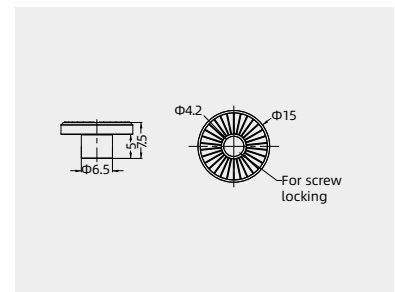

Modules dismounting instructions



Frame construction version 1 Modules dismounting instructions

Assembly instructions

Disassembly process is on the contrary.

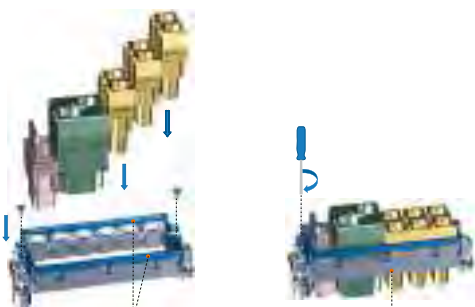

Loosen sliding border before assembly After finished assembly,close sliding border,lock screw

Frame construction version 2 Modules dismounting instructions

Assembly instructions

Disassembly instructions

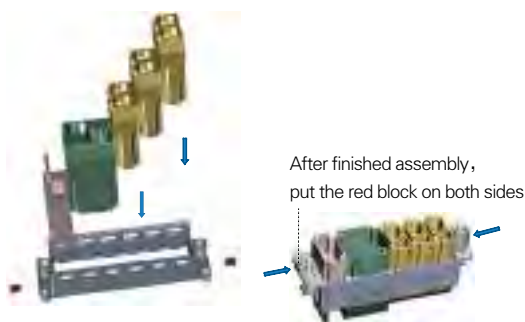

After finished assembly,
put the red block on both sides

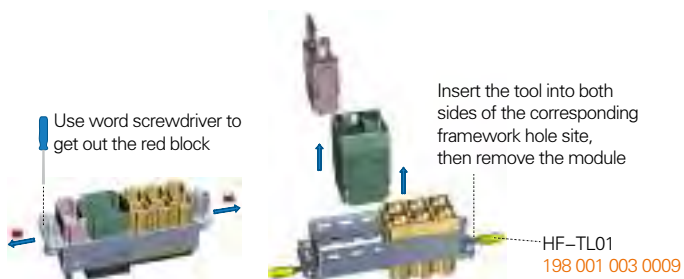

Use word screwdriver to
get out the red block

Insert the tool into both
sides of the corresponding
framework hole site,
then remove the module

HF-TL01
198 001 003 0009

PE contact Assembly instructions

Step 1: insert the stripped wire into the hole of the PE contact for crimping. (Reference stripping length 15mm⁺¹)

Step 2: Insert the crimped PE contact into the frame's grounding pin power cable (large hole) and lock the locking screw of the frame ground pin (Recommended tightening torque is 1.2Nm)



Metal enclosure for single module

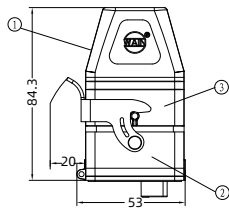

Component

The connector is only applicable to one module, and it provides a degree of protection of IP65.

- ① Top entry of the hood;
- ② Housing with a stainless steel locking lever;
- ③ Carrier hood.

Hoods/Housings

Hoods, side entry



Thread	Designation	Order No.
M25	H1M-SE-M25	129 001 590 1003

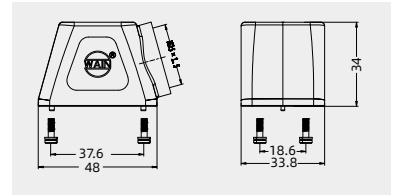

Hoods, top entry



Thread	Designation	Order No.
M25	H1M-TE-M25	129 001 490 1003

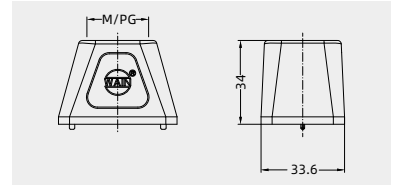

Hoods, top entry



Thread	Designation	Order No.
M32	H1M-TE-M32	129 001 490 1004

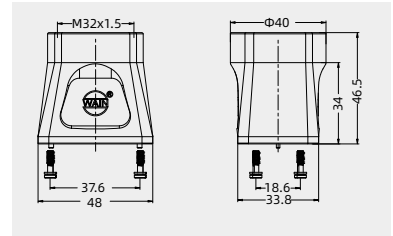

Carrier hood



Thread	Designation	Order No.
---	H1M-MBK-2B	129 001 310 1001

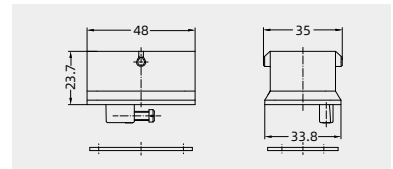

Bulkhead mounted housings



Thread	Designation	Order No.
---	H1M-BK-1L/S	129 001 325 1001

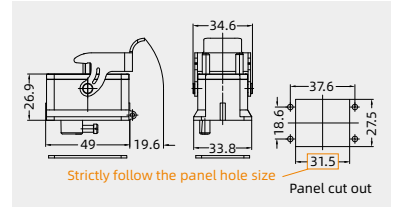

Protection covers, plastic



Thread	Designation	Order No.
---	H1M-CV-1L/1	129 001 025 8001

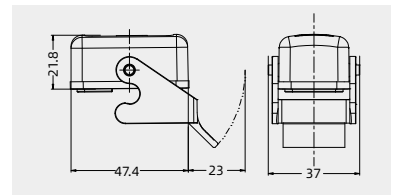

Protection covers (for Housings), plastic



Thread	Designation	Order No.
---	H1M-CV-2B/2	129 001 010 8002

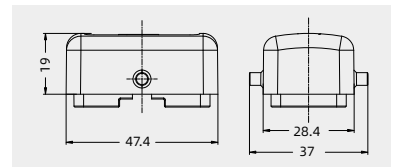

Metal enclosure for single module(EMC)-PUSH LOCK

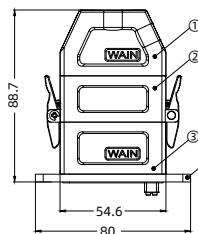
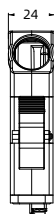

Component

- ① Hood with top or side entry;
- ② Carrier hood with locking device;
- ③ Housing, bulkhead mounted;
- ④ Mounting plate.

Hoods/Housings

Hoods, side entry



Thread	Designation	Order No.
M20	EMC.H1M.WU-SE-M20	129 001 590 1102

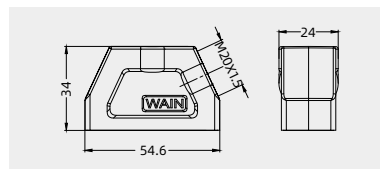

Hoods, top entry



Thread	Designation	Order No.
M20	EMC.H1M.WU-TE-M20	129 001 490 1102

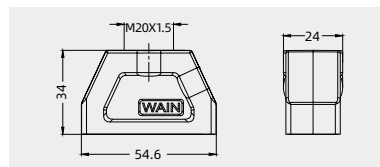

Carrier hood



Thread	Designation	Order No.
---	EMC.H1M.WU-MBK-2L	129 001 340 1001

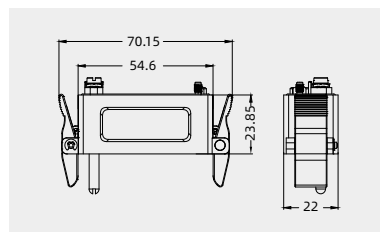

Bulkhead mounted housings



Thread	Designation	Order No.
---	EMC.H1M.WU-BK	129 001 300 1001

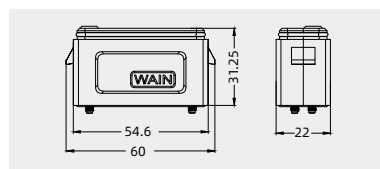

Mounting plate



Thread	Designation	Order No.
---	EMC.H1M.WU-MP	129 001 000 1101

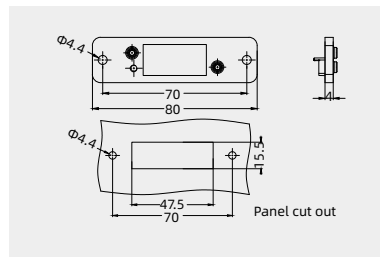

Coding element



Thread		Designation	Order No.
for Carrier hood	Male	CODE-Q7M	198 002 005 0007
for Housings	Female	CODE-Q7F	198 002 005 0008

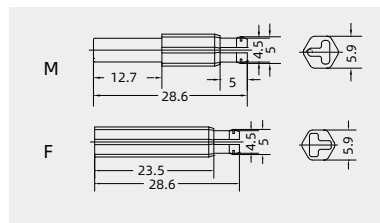

Metal enclosure for single module(EMC)

Product features

1. More compact, more powerful
2. Robust metal hoods/housings: zinc die-cast
3. Easy installation with the innovative PUSH LOCK
4. Protection against mismatching, thanks to hexagonal coding
5. Grounding solution for potential equalization
6. Large selection of standard modules
7. EMC design.



Assembly instructions

Step 1: cable will pass through cable connector. After crimping with pin (taking cold pressing pin as an example), it will be installed in male module (taking male module as an example), grounding wire will be locked at corresponding binding post of middle housing; the cable will pass through installation plate, which will be installed in the female module after crimping with pin, grounding wire will be locked at corresponding binding post; coding plug pin will be installed at selected direction, CODE-Q7M will be installed on middle housing and CODE-Q7F will be installed on the lower housing;

Step 2: cross screwdriver will be used to lock M3 screws on the middle housing and upper housing tightly to fix the male module; cross screwdriver will be used to lock M3 screws on the lower housing and face plate tightly to fix the female module; the cable connector will be tightened;

Step 3: after insertion, installation is completed.

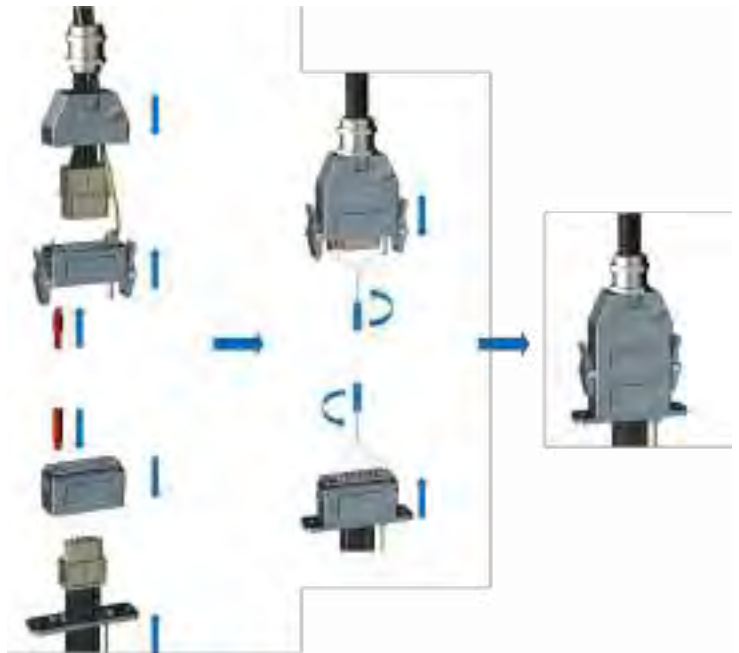

H2M metal enclosure for double module (EMC)

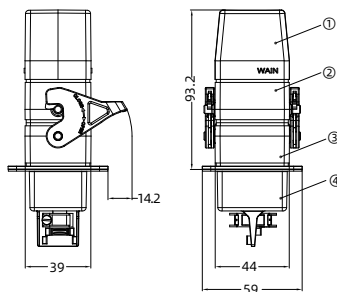

Component

- ① Hood with top or side entry;
- ② Carrier hood;
- ③ Housing with lever;
- ④ Mounting plate.

Hoods/Housings

Hoods, side entry



Thread	Designation	Order No.
M25	H2M-SE-M25	129 002 500 1001

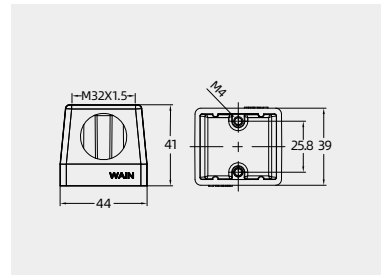

Hoods, top entry



Thread	Designation	Order No.
M25	H2M-TE-M25	129 002 400 1002
M32	H2M-TE-M32	129 002 400 1001

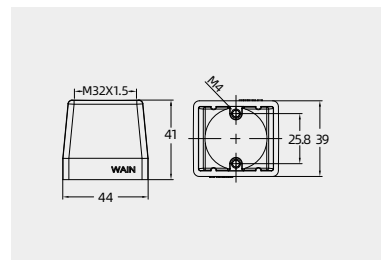

Carrier hood



Thread	Designation	Order No.
---	H2M-MBK-2B	129 002 310 1001

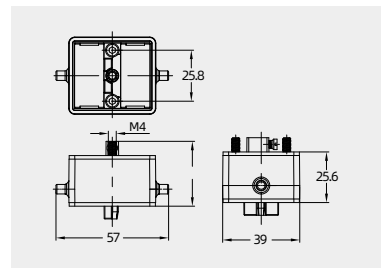

Bulkhead mounted housings



Thread	Designation	Order No.
---	H2M-BK-1L	129 002 320 1001

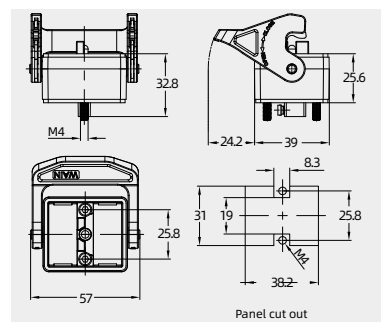

Mounting plate



Thread	Designation	Order No.
---	H2M-2CLP/BK	129 002 300 1001

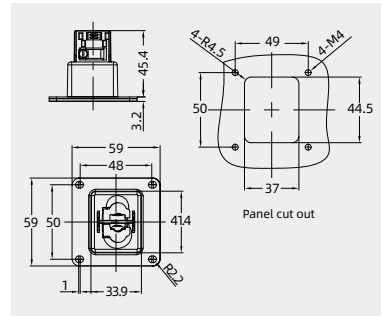

H2M metal enclosure for double module (EMC)

Product features

1. More compact, more powerful;
2. Five entry choices for hood;
3. Grounding solution for potential equalization;
4. Protection against mismatching;
5. EMC design;
6. Matching a variety of single module inserts, and can be used any two single module inserts at the same time.

Assembly instructions

Step 1: Cable will pass through cable gland. After crimping with contact (taking crimp contact as an example), it will be installed in male module (taking male module as an example), grounding wire will be locked at corresponding binding post of middle housing; the cable will pass through installation plate, which will be installed in the female module after crimping with contact, grounding wire will be locked at corresponding binding post;

Step 2: SW3 internal hexagonal wrench will be used to lock M4 screws on the middle housing and hood tightly to fix the male module; internal hexagonal wrench will be used to lock M4 screws on the housing and installation plate tightly to fix the female module; the cable gland will be tightened;

Step 3: After insertion and locking the lever, installation is completed.



Unit: mm

Dummy module



Description	Designation	Order No.
It is used to fill the spare module space in the fixed frame	HM-000	198 002 099 0008

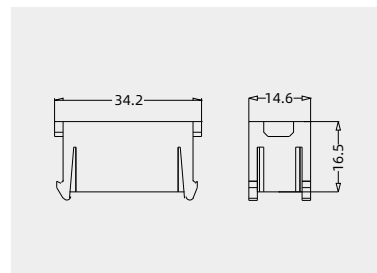

Module clamp



Description	Designation	Order No.
Applicable to with claw module, without strain relief	HM-CP1	198 002 003 0026

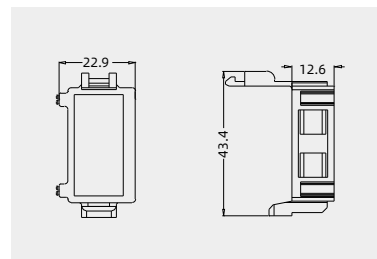

Module clamp



Description	Designation	Order No.
Applicable to with claw module, with strain relief -available to fix wires	HM-CP2	198 002 003 0027

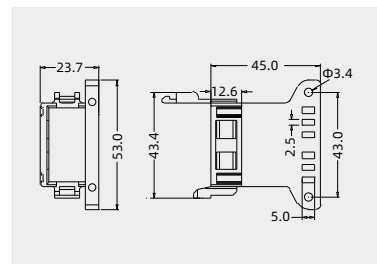

Module clamp



Description	Designation	Order No.
Applicable to module, with strain relief -available to fix wires	HM-CP2/2	198 002 003 0030

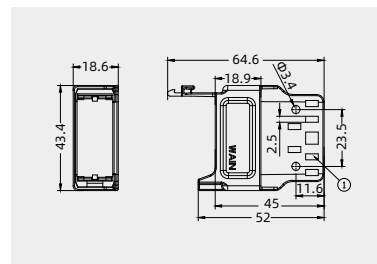

Modular Accessories

Unit: mm

Module clamp



Description	Designation	Order No.
Applicable to with claw module module, for rail	HM-CP3	198 002 003 0028

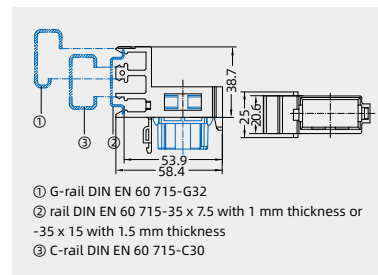

Module clamp



Description	Designation	Order No.
Applicable to module, for rail	HM-CP3/2	198 002 003 0029

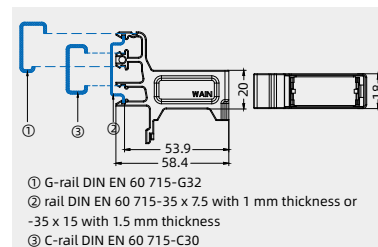

Hinged frame, size 10A hoods/housings



Description	Designation	Order No.
for 1 module	HF10A	129 010 000 1091

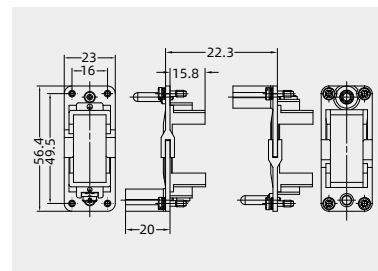

Grounding module



Description	Designation	Order No.
Only suitable for modular type plastic hoods/housings	HMPE-001-M	129 001 001 0505
	HMPE-001-F	129 001 002 0503

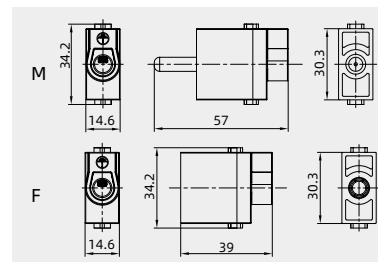

Only suitable for modular type plastic hoods/housings, Please refer to P15-25.1, P15-25.2, P15-39.1, P15-39.2, P15-108.2, P15-108.3

H2MK300-001 Crimp module

1000V 300A



Inserts



Combination with hinged frame and other modules possible.

Technical characteristics

Specifications	DIN EN 60 664 DIN EN 61 984
Approvals	
Inserts	
Number of contacts	1
Electrical data acc. to EN 61 984	
- Rated current	100A
- Rated voltage	830V
- Rated impulse voltage	8kV
- Pollution degree	3
Insulation resistance	$\geq 10^{10}\Omega$
Material	polycarbonate
Limiting temperatures	-40°C ... +125°C
Flammability acc. to UL 94	V0
Mechanical working life	≥ 500
- mating cycles	
Contacts	
Material	copper alloy
Surface	hard-silver plated
Contact resistance	$\leq 0.3m\Omega$
Crimp terminal	
- mm ²	70-120mm ²
- Stripping length	23.5mm
(When the outer diameter of the cable insulation layer $\geq 22mm$, male contact : 31mm, Female contact : 29.5mm)	

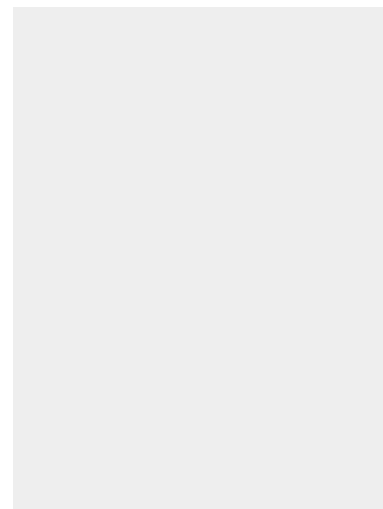

Crimp terminal

Order crimp contacts separately

Insert	Designation	Order No.
Male	H2MK300-001-MC	129 001 010 0510
Female	H2MK300-001-FC	129 001 020 0510

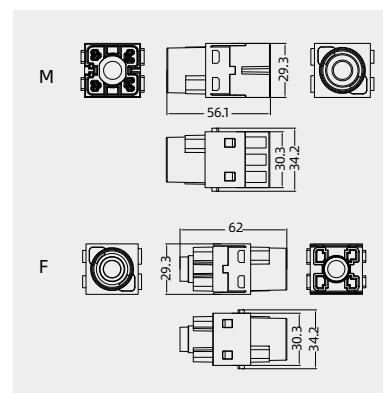

Crimp contacts

Crimp contacts 300A

Contact resistance $\leq 0.3 m\Omega$
silver plated

Male	Order No.	Female	Order No.
CHSM300-70	101 041 110 1950	CHSF300-70	101 041 120 1950
CHSM300-95	101 041 110 2050	CHSF300-95	101 041 120 2050
CHSM300-120	101 041 110 2150	CHSF300-120	101 041 120 2150

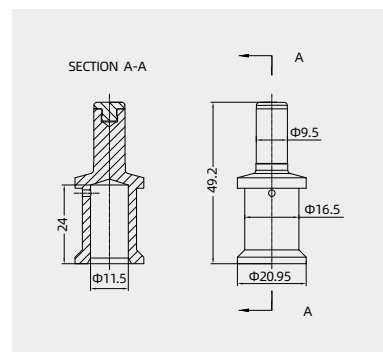

Tools

Manual hydraulic clamp

Wire gauge	Designation	Order No.
10-240mm ²	TL05	198 001 001 0005



Notes: The tools for crimp terminal may influence the product quality and stability.
Please select the tools recognized by our company.

H2MK-001 Axial module

1000V 200A

Inserts



Combination with hinged frame and other modules possible.

Technical characteristics

Specifications	DIN EN 60 664 DIN EN 61 984		
Approvals			
Inserts		Contacts	
Number of contacts	1	Material	copper alloy
Electrical data acc. to EN 61 984		Surface	hard-silver plated
-Rated current	200A	Contact resistance	0.2mΩ
-Rated voltage	1000V	For stranded wire according to IEC 60 228 Class 5	
-Rated impulse voltage	8kV	Screw terminal	
-Pollution degree	3	- Wire gauge	25-70mm ²
Rated voltage acc. to UL	600V	- AWG	2-0
Insulation resistance	≥ 10 ¹⁰ Ω	- Hexagonal driver	SW 5
Material	polycarbonate	- Stripping length	16mm
Limiting temperatures	-40°C ...+125°C	- Tightening torque	
Flammability acc. to UL 94	V0	-mm ²	25 35 50 70
Mechanical working life	≥ 500	-Nm	8 8 9 10
- mating cycles			

Current carrying capacity

The current carrying is limited by maximum temperature of materials for inserts and contacts including terminals

Control and test procedures according to DIN EN 60512-5

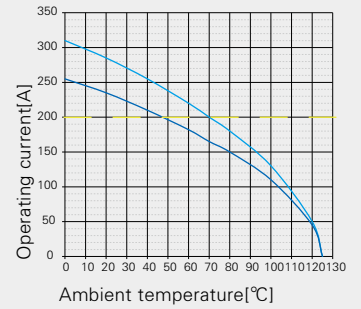

— 24 B hoods/housings with 3 modules, wire gauge: 70mm²
 — 24 B hoods/housings with 3 modules, wire gauge: 50mm²

Axial screw terminal¹⁾



Insert	Wire gauge	Designation	Order No.
Male	25-40mm ²	H2MK-001.1-M (25-40mm ²)	129 001 011 0101
	40-70mm ²	H2MK-001.2-M (40-70mm ²)	129 001 011 0102
Female	25-40mm ²	H2MK-001.1-F (25-40mm ²)	129 001 021 0101
	40-70mm ²	H2MK-001.2-F (40-70mm ²)	129 001 021 0102

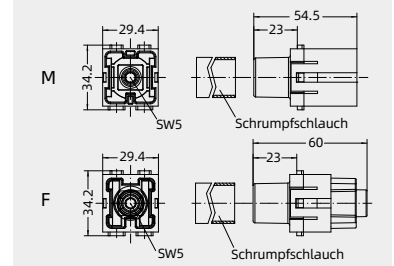

Accessories

Tool

hexagonal driver



Description	Designation	Order No.
for axial setscrew with grip	SW-5*150	198 001 003 0007

¹⁾ See P00-12-00-13 for the structural characteristics and description of Axial screw terminal.

H2MKPE-001 Axial grounding module

1000V 200A+

Inserts



Combination with hinged frame and other modules possible.

Technical characteristics

Specifications	DIN EN 60 664 DIN EN 61 984
Approvals	
Inserts	
Number of contacts	1
Electrical data acc. to EN 61 984	
- Rated current	200A
- Rated voltage	1000V
- Rated impulse voltage	8kV
- Pollution degree	3
Rated voltage acc. to UL	600V
Insulation resistance	$\geq 10^{10}\Omega$
Material	polycarbonate
Limiting temperatures	-40°C ... +125°C
Flammability acc. to UL 94	V0
Mechanical working life	≥ 500
- mating cycles	
Contacts	
Material	copper alloy
Surface	hard-silver plated
Contact resistance	0.2mΩ
For stranded wire according to IEC 60 228 Class 5	
Screw terminal	25-70mm ²
- Wire gauge	2-0
- AWG	SW 5
- Hexagonal driver	16mm
- Stripping length	
- Tightening torque	25 35 50 70
-mm ²	8 8 9 10
-Nm	

Current carrying capacity

The current carrying is limited by maximum temperature of materials for inserts and contacts including terminals

Control and test procedures according to DIN EN 60512-5

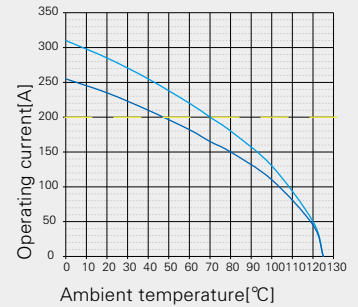

— 24 B hoods/housings with 3 modules, wire gauge: 70mm²
 — 24 B hoods/housings with 3 modules, wire gauge: 50mm²

Axial screw terminal¹⁾



Insert	Wire gauge	Designation	Order No.
Male	25-40mm ²	H2MKPE-001.1-M(25-40mm ²)	129 001 011 0001
	40-70mm ²	H2MKPE-001.2-M(40-70mm ²)	129 001 011 0002
Female	25-40mm ²	H2MKPE-001.1-F(25-40mm ²)	129 001 021 0001
	40-70mm ²	H2MKPE-001.2-F(40-70mm ²)	129 001 021 0002

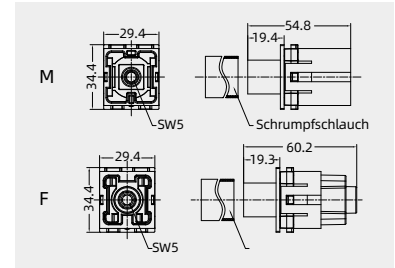

Accessories

Tool

hexagonal driver



Description	Designation	Order No.
for axial setscrew with grip	SW-5*150	198 001 003 0007

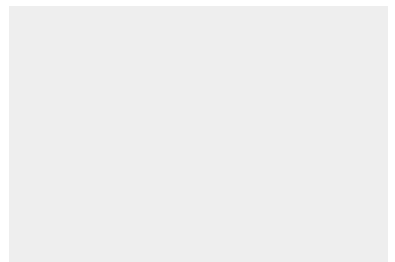

H2MK-001 Crimp module

1000V 200A

Inserts



Combination with hinged frame and other modules possible.

Technical characteristics

Specifications	DIN EN 60 664 DIN EN 61 984		
Approvals	VDE CE ENEC		
Inserts		Contacts	
Number of contacts	1	Material	copper alloy
Electrical data acc. to EN 61 984		Surface	hard-silver plated
-Rated current	200A	Contact resistance	≤ 0.3mΩ
-Rated voltage	1000V	Crimp terminal	
-Rated impulse voltage	8kV	- mm ²	25-70mm ²
-Pollution degree	3	Stripping length	22.5mm
Insulation resistance	≥ 10 ¹⁰ Ω	Max. insulation diameter	18mm
Material	polycarbonate		
Limiting temperatures	-40°C ...+125°C		
Flammability acc. to UL 94	V0		
Mechanical working life			
- mating cycles	≥ 500		

Current carrying capacity

The current carrying is limited by maximum temperature of materials for inserts and contacts including terminals

Control and test procedures according to DIN EN 60512-5

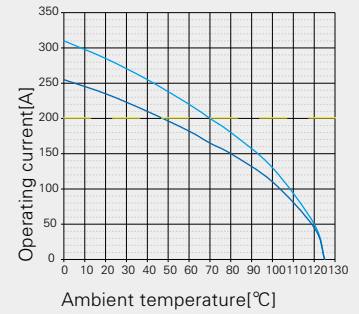

— 24 B hoods/housings with 3 modules, wire gauge: 70mm²
 — 24 B hoods/housings with 3 modules, wire gauge: 50mm²

Crimp terminal

Order crimp contacts separately



Insert	Designation	Order No.
Male	H2MK-001-MC	129 001 010 0101
Female	H2MK-001-FC	129 001 020 0101

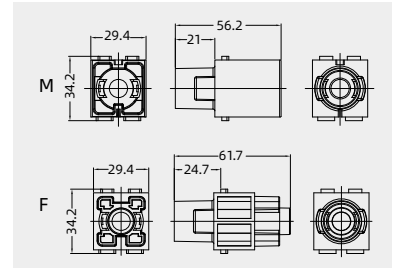

Crimp contacts

Crimp contacts 200A

Contact resistance ≤ 0.3 mΩ
silver plated



Male	Order No.	Female	Order No.
CHSM200-25	101 027 110 1601	CHSF200-25	101 027 120 1601
CHSM200-35	101 027 110 1701	CHSF200-35	101 027 120 1701
CHSM200-50	101 027 110 1801	CHSF200-50	101 027 120 1801
CHSM200-70	101 027 110 1901	CHSF200-70	101 027 120 1901

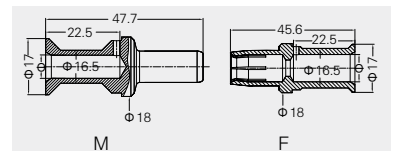

Wire gauge	Φ	Stripping length
25 mm ²	7	22.5 mm
35 mm ²	8,2	22.5 mm
50 mm ²	10	22.5 mm
70 mm ²	11,5	22.5 mm

for stranded wire according to IEC 60 228 Class 5

Tools

Manual hydraulic clamp



Wire gauge	Designation	Order No.
10-240mm ²	TL05	198 001 001 0005

Notes: The tools for crimp terminal may influence the product quality and stability. Please select the tools recognized by our company.

HMK-001 Crimp module

830V 100A

Inserts



Combination with hinged frame and other modules possible.
Cannot match the metal hood with side entry:EMC.H1M.WU-SE-M20.

Technical characteristics

Specifications	DIN EN 60 664 DIN EN 61 984		
Approvals			
Inserts		Contacts	
Number of contacts	1	Material	copper alloy
Electrical data acc. to EN 61 984		Surface	hard-silver plated
-Rated current	100A	Contact resistance	≤ 0.3mΩ
-Rated voltage	830V	Crimp terminal	
-Rated impulse voltage	8kV	-mm ²	10-35mm ²
-Pollution degree	3		
Insulation resistance	≥ 10 ¹⁰ Ω		
Material	polycarbonate		
Limiting temperatures	-40°C ...+125°C		
Flammability acc. to UL 94	V0		
Mechanical working life			
- mating cycles	≥ 500		
Max. insulation diameter	13mm		

Crimp terminal

Order crimp contacts separately



Insert	Designation	Order No.
Male	HMK-001-MC	129 001 010 0001
Female	HMK-001-FC	129 001 020 0001

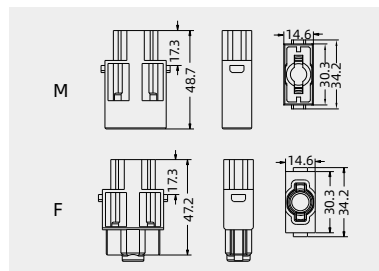

Crimp contacts

Crimp contacts 100A

Contact resistance ≤ 0.3 mΩ
silver plated



Male	Order No.	Female	Order No.
CKSM-10	101 026 110 1401	CKSF-10G	101 026 120 1403
CKSM-16	101 026 110 1501	CKSF-16G	101 026 120 1503
CKSM-25	101 026 110 1601	CKSF-25G	101 026 120 1603
CKSM-35	101 026 110 1701	CKSF-35G	101 026 120 1703

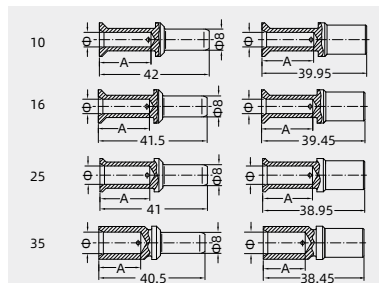

Wire gauge	Φ	Stripping length(A)
10 mm ²	4.3	19 mm
16 mm ²	5.5	19 mm
25 mm ²	7	19 mm
35 mm ²	8.2	16 mm

for stranded wire acc. to IEC 60 228 Class 5

Tools

Manual hydraulic clamp



Contact removal tool



Wire gauge	Designation	Order No.
10-240mm ²	TL05	198 001 001 0005

Application	Designation	Order No.
for crimp contacts 100A	TL11	198 001 000 0018

Notes: The tools for crimp terminal may influence the product quality and stability.
Please select the tools recognized by our company.

HMPE.M Axial grounding module



Inserts



Combination with hinged frame and other modules possible.

Technical characteristics

Specifications	DIN EN 60 664 DIN EN 61 984		
Approvals			
Inserts	Contacts		
Number of contacts	1	Material	copper alloy
Limiting temperatures	-40°C ...+125°C	Surface	hard-silver plated
Mechanical working life		For stranded wire according	0.3mΩ
- mating cycles	≥ 500	to IEC 60 228 Class 5	
Material	zinc alloy	Screw terminal	
Surface	nickeling	- Wire gauge	10-35mm ²
		- AWG	6-2
		- Hexagonal driver	SW 4
		- Stripping length	13mm
		- Tightening torque	
		-mm ²	10 16 25 35
		-Nm	6 6 7 8

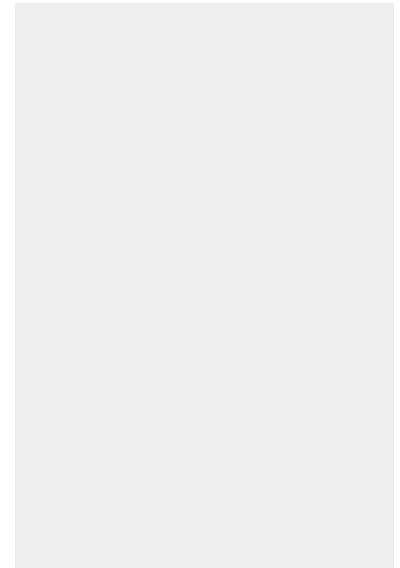

Axial screw terminal¹⁾



Insert	Wire gauge	Designation	Order No.
Male	10-25mm ²	HMPE.M-001.1-M	129 001 001 0507
	16-35mm ²	HMPE.M-001.2-M	129 001 001 0508
Female	10-25mm ²	HMPE.M-001.1-F	129 001 002 0504
	16-35mm ²	HMPE.M-001.2-F	129 001 002 0505

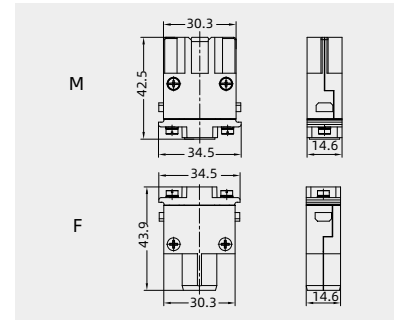

Accessories

Tool

hexagonal driver



Description	Designation	Order No.
for axial setscrew with grip	SW-4*150	198 001 003 0007

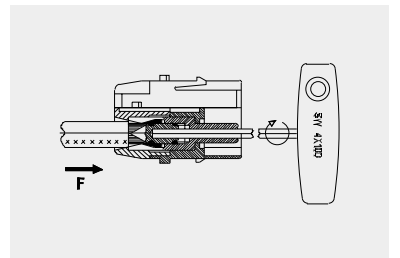

HMPE.M 冷压型接地模块



Combination with hinged frame and other modules possible.

Inserts

Technical characteristics

Specifications	DIN EN 60 664 DIN EN 61 984
Approvals	
Inserts	Contacts
Number of contacts	1
Limiting temperatures	-40°C ...+125°C
Mechanical working life	≥ 500
- mating cycles	
Max. insulation diameter	13mm
Material	zinc alloy
Surface	nickeling

Crimp terminal
Order crimp contacts separately



Insert	Designation	Order No.
Male	HMPE.M-001-MC	129 001 010 0511
Female	HMPE.M-001-FC	129 001 020 0511

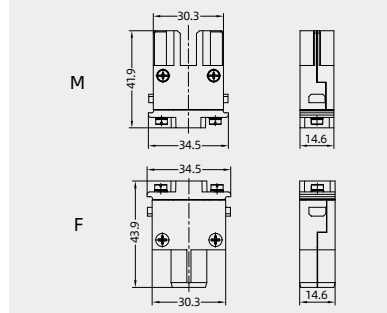

Crimp contacts

Crimp contacts 100A
Contact resistance ≤ 0.3 mΩ
silver plated



Male	Order No.	Female	Order No.
CKSM-10	101 026 110 1401	CKSF-10G	101 026 120 1403
CKSM-16	101 026 110 1501	CKSF-16G	101 026 120 1503
CKSM-25	101 026 110 1601	CKSF-25G	101 026 120 1603
CKSM-35	101 026 110 1701	CKSF-35G	101 026 120 1703

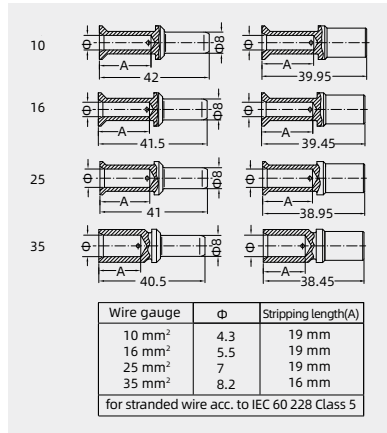

Tools
Manual hydraulic clamp



Wire gauge	Designation	Order No.
10-240mm ²	TL05	198 001 001 0005

Notes: The tools for crimp terminal may influence the product quality and stability. Please select the tools recognized by our company.

H2MK-002 Axial module

1000V 100A

Inserts



Combination with hinged frame and other modules possible.

Technical characteristics

Specifications	DIN EN 60 664 DIN EN 61 984		
Approvals			
Inserts		Contacts	
Number of contacts	2	Material	copper alloy
Electrical data acc. to EN 61 984		Surface	hard-silver plated
-Rated current	100A	Contact resistance	0.3mΩ
-Rated voltage	1000V	For stranded wire according to IEC 60 228 Class 5	
-Rated impulse voltage	8kV	Screw terminal	10-35mm ²
-Pollution degree	3	- Wire gauge	6-2
Rated voltage acc. to UL	600V	- AWG	SW 4
Insulation resistance	≥ 10 ¹⁰ Ω	- Hexagonal driver	13mm
Material	polycarbonate	- Stripping length	
Limiting temperatures	-40°C ...+125°C	- Tightening torque	10 16 25 35
Flammability acc. to UL 94	V0	-mm ²	6 6 7 8
Mechanical working life		-Nm	
- mating cycles	≥ 500		

Current carrying capacity

The current carrying is limited by maximum temperature of materials for inserts and contacts including terminals

Control and test procedures according to DIN EN 60512-5

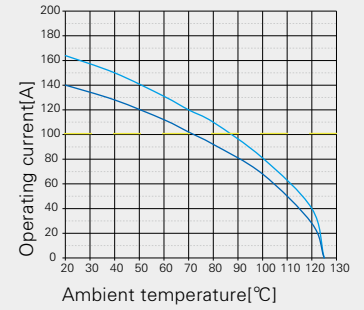

— 24 B hoods/housings with 3 modules, wire gauge: 35mm²
 — 24 B hoods/housings with 3 modules, wire gauge: 25mm²

Axial screw terminal¹⁾



Insert	Wire gauge	Designation	Order No.
Male	10-25mm ²	H2MK-002.1-M (10-25mm ²)	129 002 011 0101
	16-35mm ²	H2MK-002.2-M (16-35mm ²)	129 002 011 0102
Female	10-25mm ²	H2MK-002.1-F (10-25mm ²)	129 002 021 0101
	16-35mm ²	H2MK-002.2-F (16-35mm ²)	129 002 021 0102

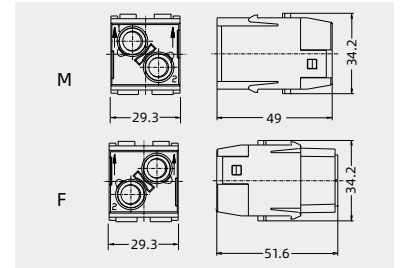

Accessories

Cable shoe 16mm²



Description	Designation	Order No.
for PE extension	PE-E16 ²⁾	198 002 006 0014

²⁾ Use of PE pin is shown in P10-08.

Cable shoe 25mm²



Description	Designation	Order No.
for PE extension	PE-E25 ²⁾	198 002 006 0020

²⁾ Use of PE pin is shown in P10-08.
 Suitable for metal frame: HFXB-NUA2/HFXB-NLA2

Tool

hexagonal driver



Description	Designation	Order No.
for axial setscrew with grip	SW-4*150	198 001 003 0001

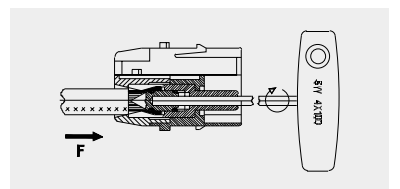
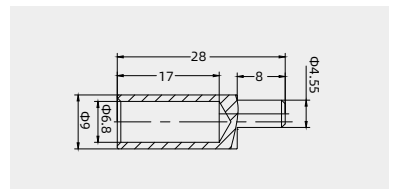
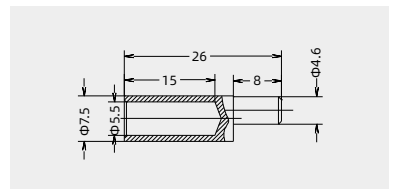

¹⁾ See P00-12-00-13 for the structural characteristics and description of Axial screw terminal.

H2MK-002 Crimp module

1000V 100A

Inserts



Combination with hinged frame and other modules possible.

Technical characteristics

Specifications	DIN EN 60 664 DIN EN 61 984		
Approvals			
Inserts		Contacts	
Number of contacts	2	Material	copper alloy
Electrical data acc. to EN 61 984		Surface	hard-silver plated
-Rated current	100A	Contact resistance	≤ 0.3mΩ
-Rated voltage	1000V	Crimp terminal	
-Rated impulse voltage	8kV	- mm ²	10-35mm ²
-Pollution degree	3	Max. insulation diameter	14mm
Insulation resistance	≥ 10 ¹⁰ Ω		
Material	polycarbonate		
Limiting temperatures	-40°C ...+125°C		
Flammability acc. to UL 94	V0		
Mechanical working life			
- mating cycles	≥ 500		

Current carrying capacity

The current carrying is limited by maximum temperature of materials for inserts and contacts including terminals

Control and test procedures according to DIN EN 60512-5

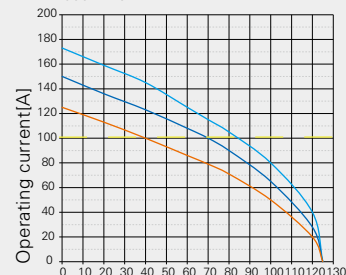

Ambient temperature[°C]
 — 24 B hoods/housings with 3 modules, wire gauge: 35mm²
 — 24 B hoods/housings with 3 modules, wire gauge: 25mm²
 — 24 B hoods/housings with 3 modules, wire gauge: 16mm²

Crimp terminal

Order crimp contacts separately



Insert	Designation	Order No.
Male	H2MK-002-MC	129 002 010 0101
Female	H2MK-002-FC	129 002 020 0101

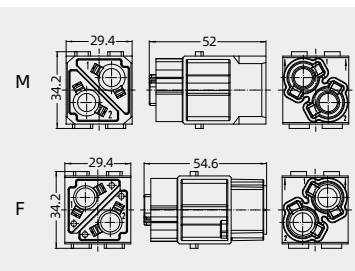

Crimp contacts

Crimp contacts 100A

Contact resistance ≤ 0.3 mΩ silver plated



Male	Order No.	Female	Order No.
CKSM-10	101 026 110 1401	CKSF-10G	101 026 120 1403
CKSM-16	101 026 110 1501	CKSF-16G	101 026 120 1503
CKSM-25	101 026 110 1601	CKSF-25G	101 026 120 1603
CKSM-35	101 026 110 1701	CKSF-35G	101 026 120 1703

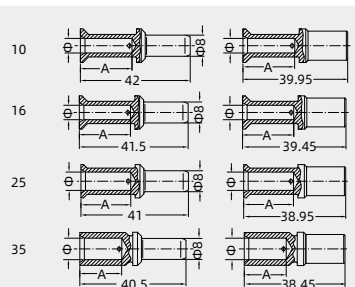

Tools

Manual hydraulic clamp



Contact removal tool



Wire gauge	Designation	Order No.
10-240mm ²	TL05	198 001 001 0005

Application	Designation	Order No.
for crimp contacts 100A	TL11	198 001 000 0018

Wire gauge	Φ	Stripping length(A)
10 mm ²	4.3	19 mm
16 mm ²	5.5	19 mm
25 mm ²	7	19 mm
35 mm ²	8.2	16 mm

for stranded wire acc. to IEC 60 228 Class 5

Notes: The tools for crimp terminal may influence the product quality and stability. Please select the tools recognized by our company.

HMK70-002 Axial module

1000V 70A

Inserts



Combination with hinged frame and other modules possible.

Technical characteristics

Specifications	DIN EN 60 664 DIN EN 61 984		
Approvals			
Inserts		Contacts	
Number of contacts	2	Material	copper alloy
Electrical data acc. to EN 61 984		Surface	hard-silver plated
-Rated current	70A	Contact resistance	0.5mΩ
-Rated voltage	1000V	For stranded wire according to IEC 60 228 Class 5	
-Rated impulse voltage	8kV	Screw terminal	
-Pollution degree	3	-mm ²	6-22mm ²
Rated voltage acc. to UL	600V	-AWG	8-4
Insulation resistance	≥ 10 ¹⁰ Ω	-Hexagonal driver	SW 2.5
Material	polycarbonate	-Stripping length	
Limiting temperatures	-40°C ... +125°C	-mm ²	6 10 16 22
Flammability acc. to UL 94	V0	-mm ²	11 ⁺¹ 11 ⁺¹ 11 ⁺¹ 12.5 ⁺¹
Mechanical working life		-Tightening torque	
- mating cycles	≥ 500	-mm ²	6 10 16 22
		-Nm	2 3 4 5

Current carrying capacity

The current carrying is limited by maximum temperature of materials for inserts and contacts including terminals

Control and test procedures according to DIN EN 60512-5

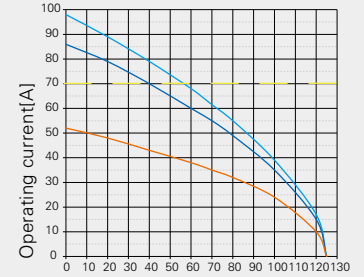

Ambient temperature[°C]

- 24 B hoods/housings with 6 modules, wire gauge: 22mm²
- 24 B hoods/housings with 6 modules, wire gauge: 16mm²
- 24 B hoods/housings with 6 modules, wire gauge: 6mm²

Axial screw terminal¹⁾



Insert	Wire gauge	Designation	Order No.
Male	6-16mm ²	HMK70-002.1-M (6-16mm ²)	129 002 011 0201
	14-22mm ²	HMK70-002.2-M (14-22mm ²)	129 002 011 0202
Female	6-16mm ²	HMK70-002.1-F (6-16mm ²)	129 002 021 0201
	14-22mm ²	HMK70-002.2-F (14-22mm ²)	129 002 021 0202

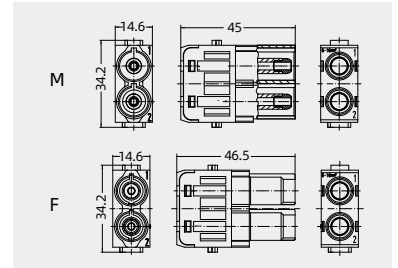

Accessories

Tool

hexagonal driver



Description	Designation	Order No.
for axial setscrew with grip	SW-2.5*100	198 001 003 0003

¹⁾ See P00-12-00-13 for the structural characteristics and description of Axial screw terminal.

HMK70-002 Crimp Module

1000V 70A

Inserts



Combination with hinged frame and other modules possible.

Technical characteristics

Specifications	DIN EN 60 664 DIN EN 61 984		
Approvals			
Inserts		Contacts	
Number of contacts	2	Material	copper alloy
Electrical data acc. to EN 61 984		Surface	hard-silver plated
- Rated current	70A	Contact resistance	≤ 0.5mΩ
- Rated voltage	1000V	Crimp terminal	
- Rated impulse voltage	8kV	- wire gauge	10-25mm ²
- Pollution degree	3	Max. insulation diameter	11mm
Insulation resistance	≥ 1010Ω	Stripping length	15.5mm
Material	polycarbonate		
Limiting temperatures	-40°C ... +125°C		
Flammability acc. to UL 94	V0		
Mechanical working life			
- mating cycles	≥ 500		

Crimp terminal

Order crimp contacts separately



Insert	Designation	Order No.
Male	HMK70-002-MC	129 002 010 0201
Female	HMK70-002-FC	129 002 020 0201

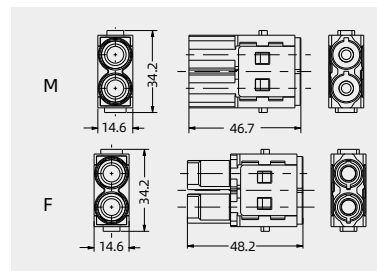

Crimp contacts

Crimp contacts 70A

Contact resistance ≤ 0.5 mΩ
silver plated



Male	Order No.	Female	Order No.
CKSM70-6	101 034 110 1301	CKSF70-6	101 034 120 1301
CKSM70-10	101 034 110 1401	CKSF70-10	101 034 120 1401
CKSM70-16	101 034 110 1501	CKSF70-16	101 034 120 1501
CKSM70-25	101 034 110 1601	CKSF70-25	101 034 120 1601

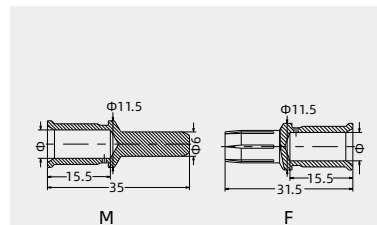

Wire gauge	Φ	Stripping length
6 mm ²	3.5	15.5 mm
10 mm ²	4.3	15.5 mm
16 mm ²	5.5	15.5 mm
25 mm ²	7	15.5 mm

for stranded wire acc. to IEC 60 228 Class 5

Tools

Manual hydraulic clamp



Wire gauge	Designation	Order No.
10-240mm ²	TL05	198 001 001 0005

Notes: The tools for crimp terminal may influence the product quality and stability. Please select the tools recognized by our company.

HMK-002 Axial module

1000V 40A

Inserts



Combination with hinged frame and other modules possible.

Technical characteristics

Specifications	DIN EN 60 664 DIN EN 61 984		
Approvals			
Inserts		Contacts	
Number of contacts	2	Material	copper alloy
Electrical data acc. to EN 61 984		Surface	hard-silver plated
-Rated current	40A	Contact resistance	1mΩ
-Rated voltage	1000V	Screw terminal	
-Rated impulse voltage	8kV	- Wire gauge	2.5-10mm ²
-Pollution degree	3	-AWG	14-8
Rated voltage acc. to UL	600V	-Hexagonal driver	SW 2
Insulation resistance	≥ 10 ¹⁰ Ω	- Stripping length	
Material	polycarbonate	-mm ²	2.5 4 6 10
Limiting temperatures	-40°C ...+125°C	-mm ²	5 ⁺¹ 5 ⁺¹ 8 ⁺¹ 11 ⁺¹
Flammability acc. to UL 94	V0	-Tightening torque	
Mechanical working life		-mm ²	2.5 4 6 10
- mating cycles	≥ 500	-Nm	1.5 1.5 2 2

Current carrying capacity

The current carrying is limited by maximum temperature of materials for inserts and contacts including terminals

Control and test procedures according to DIN EN 60512-5

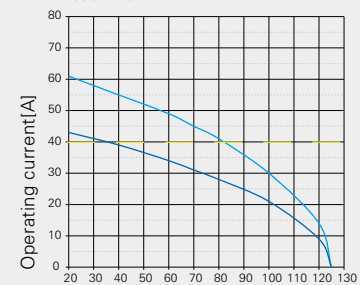

Ambient temperature[°C]

- 24 B hoods/housings with 6 modules, wire gauge: 10mm²
- 24 B hoods/housings with 6 modules, wire gauge: 6mm²

Axial screw terminal¹⁾



Insert	Wire gauge	Designation	Order No.
Male	2.5-8mm ²	HMK-002.1-M (2.5-8mm ²)	129 002 011 0003
	6-10mm ²	HMK-002.2-M (6-10mm ²)	129 002 011 0004
Female	2.5-8mm ²	HMK-002.1-F (2.5-8mm ²)	129 002 021 0003
	6-10mm ²	HMK-002.2-F (6-10mm ²)	129 002 021 0004

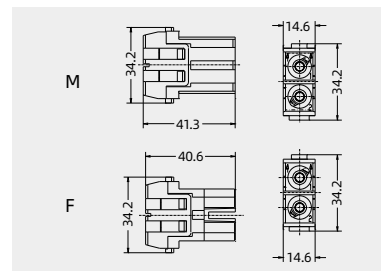

Accessories

Tool

hexagonal driver



Description	Designation	Order No.
for axial setscrew with grip	SW-2*100	198 001 003 0002

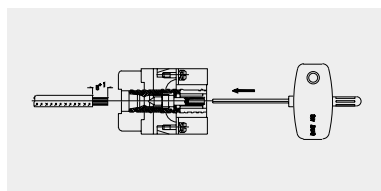

¹⁾ See P00-12-00-13 for the structural characteristics and description of Axial screw terminal.

HMK-002 Crimp module

1000V 40A

Inserts



Combination with hinged frame and other modules possible.

Technical characteristics

Specifications	DIN EN 60 664 DIN EN 61 984		
Approvals			
Inserts		Contacts	
Number of contacts	2	Material	copper alloy
Electrical data acc. to EN 61 984		Surface	hard-silver plated
-Rated current	40A	Contact resistance	≤ 1mΩ
-Rated voltage	1000V	Crimp terminal	
-Rated impulse voltage	8kV	-mm ²	1.5-10mm ²
-Pollution degree	3	-AWG	16-8
Insulation resistance	≥ 10 ¹⁰ Ω		
Material	polycarbonate		
Limiting temperatures	-40°C ...+125°C		
Flammability acc. to UL 94	V0		
Mechanical working life			
- mating cycles	≥ 500		

Current carrying capacity

The current carrying is limited by maximum temperature of materials for inserts and contacts including terminals

Control and test procedures according to DIN EN 60512-5

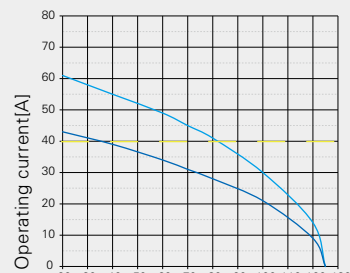

Ambient temperature [°C]

- 24 B hoods/housings with 6 modules, wire gauge: 10mm²
- 24 B hoods/housings with 6 modules, wire gauge: 6mm²

Crimp terminal

Order crimp contacts separately



Insert	Designation	Order No.
Male	HMK-002-MC	129 002 010 0001
Female	HMK-002-FC	129 002 020 0001

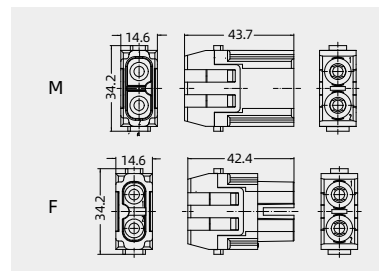

Crimp contacts

Crimp contacts 40A

Contact resistance ≤ 1 mΩ
silver plated



Male	Order No.	Female	Order No.
CCSM-1.5	101 023 110 0901	CCSF-1.5	101 023 120 0901
CCSM-2.5	101 023 110 1001	CCSF-2.5	101 023 120 1001
CCSM-4.0	101 023 110 1201	CCSF-4.0	101 023 120 1201
CCSM-6.0	101 023 110 1301	CCSF-6.0	101 023 120 1301
CCSM-10.0	101 023 110 1401	CCSF-10.0	101 023 120 1401

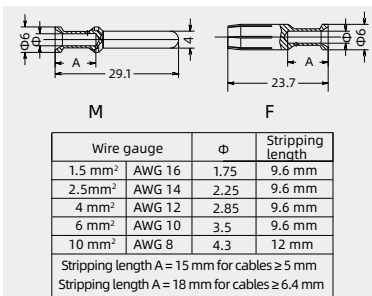

Tools

Crimping tool



Contact removal tool



Wire gauge	Designation	Order No.
1.5-6mm ²	TL02-0G	198 001 001 0012
4/6/10mm ²	TL02-3G	198 001 001 0013

Application	Designation	Order No.
for crimp contacts 40A	TL06G	198 001 000 0009

Notes: The tools for crimp terminal may influence the product quality and stability. Please select the tools recognized by our company.

HMK-003 Axial module

690V 40A

Inserts



Combination with hinged frame and other modules possible.

Technical characteristics

Specifications	DIN EN 60 664 DIN EN 61 984		
Approvals			
Inserts	Contacts		
Number of contacts	3	Material	copper alloy
Electrical data acc. to EN 61 984		Surface	hard-silver plated
-Rated current	40A	Contact resistance	1mΩ
-Rated voltage	690V	Screw terminal	
-Rated impulse voltage	8kV	- Wire gauge	2.5-10mm ²
-Pollution degree	3	-AWG	14-8
Rated voltage acc. to UL	600V	-Hexagonal driver	SW 2
Insulation resistance	≥ 10 ¹⁰ Ω	- Stripping length	
Material	polycarbonate	-mm ²	2.5 4 6 10
Limiting temperatures	-40°C ...+125°C	-mm ²	5 ⁺¹ 5 ⁺¹ 8 ⁺¹ 11 ⁺¹
Flammability acc. to UL 94	V0	-Tightening torque	
Mechanical working life		-mm ²	2.5 4 6 10
- mating cycles	≥ 500	-Nm	1.5 1.5 2 2

Current carrying capacity

The current carrying is limited by maximum temperature of materials for inserts and contacts including terminals

Control and test procedures according to DIN EN 60512-5

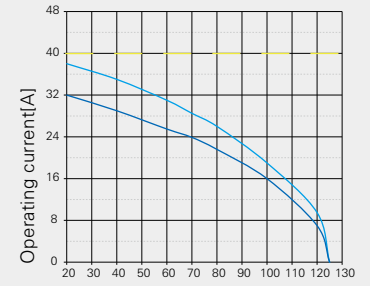

— 24 B hoods/housings with 6 modules, wire gauge: 6mm²
 — 24 B hoods/housings with 6 modules, wire gauge: 4mm²

Axial screw terminal¹⁾



Insert	Wire gauge	Designation	Order No.
Male	2.5-8mm ²	HMK-003.1-M (2.5-8mm ²)	129 003 011 0001
	6-10mm ²	HMK-003.2-M (6-10mm ²)	129 003 011 0002
Female	2.5-8mm ²	HMK-003.1-F (2.5-8mm ²)	129 003 021 0001
	6-10mm ²	HMK-003.2-F (6-10mm ²)	129 003 021 0002

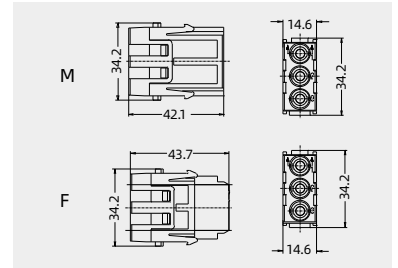

Accessories

Tool

hexagonal driver



Description	Designation	Order No.
for axial setscrew with grip	SW-2*100	198 001 003 0002

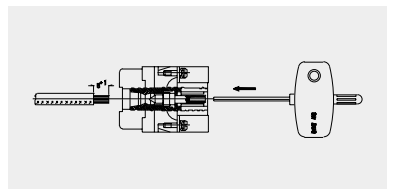

¹⁾ See P00-12-00-13 for the structural characteristics and description of Axial screw terminal.

HMK-003 Crimp module

500V 40A

Inserts



Combination with hinged frame and other modules possible.

Technical characteristics

Specifications	DIN EN 60 664 DIN EN 61 984		
Approvals			
Inserts		Contacts	
Number of contacts	3	Material	copper alloy
Electrical data acc. to EN 61 984		Surface	hard-silver plated
Cable diameter up to 7.5 mm		Contact resistance	≤ 1mΩ
-Rated current	40A	Crimp terminal	
-Rated voltage	500V	-mm ²	1.5-10mm ²
-Rated impulse voltage	6kV	-AWG	16-8
-Pollution degree	3		
Rated voltage acc. to UL	600V		
Rated current acc. to UL	32A		
Insulation resistance	≥ 10 ¹⁰ Ω		
Material	polycarbonate		
Limiting temperatures	-40°C ...+125°C		
Flammability acc. to UL 94	V0		
Mechanical working life			
- mating cycles	≥ 500		

Current carrying capacity

The current carrying is limited by maximum temperature of materials for inserts and contacts including terminals

Control and test procedures according to DIN EN 60512-5

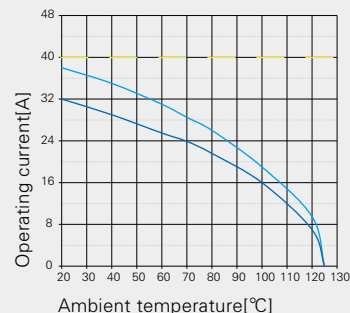

— 24 B hoods/housings with 6 modules, wire gauge: 6mm²
 — 24 B hoods/housings with 6 modules, wire gauge: 4mm²

Crimp terminal

Order crimp contacts separately



Insert	Designation	Order No.
Male	HMK-003-MC	129 003 010 0001
Female	HMK-003-FC	129 003 020 0001

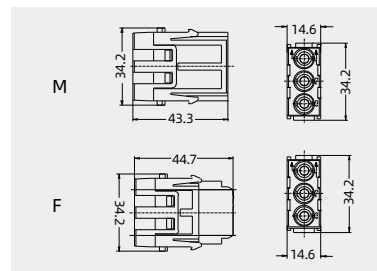

Crimp contacts

Crimp contacts 40A

Contact resistance ≤ 1 mΩ
silver plated



Male	Order No.	Female	Order No.
CCSM-1.5	101 023 110 0901	CCSF-1.5	101 023 120 0901
CCSM-2.5	101 023 110 1001	CCSF-2.5	101 023 120 1001
CCSM-4.0	101 023 110 1201	CCSF-4.0	101 023 120 1201
CCSM-6.0	101 023 110 1301	CCSF-6.0	101 023 120 1301
CCSM-10.0	101 023 110 1401	CCSF-10.0	101 023 120 1401

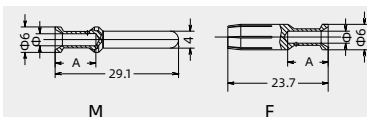

Wire gauge	Φ	Stripping length
1.5 mm ²	AWG 16	1.75
2.5 mm ²	AWG 14	2.25
4 mm ²	AWG 12	2.85
6 mm ²	AWG 10	3.5
10 mm ²	AWG 8	4.3

Stripping length A = 15 mm for cables ≥ 5 mm
 Stripping length A = 18 mm for cables ≥ 6.4 mm

Tools

Crimping tool



Contact removal tool



Wire gauge	Designation	Order No.
1.5-6mm ²	TL02-0G	198 001 001 0012
4/6/10mm ²	TL02-3G	198 001 001 0013

Application	Designation	Order No.
for crimp contacts 40A	TL06G	198 001 000 0009

Notes: The tools for crimp terminal may influence the product quality and stability. Please select the tools recognized by our company.

HMK-003 Crimp module

690V 40A

Inserts



Combination with hinged frame and other modules possible.

Technical characteristics

Specifications	DIN EN 60 664 DIN EN 61 984		
Approvals			
Inserts		Contacts	
Number of contacts	3	Material	copper alloy
Electrical data acc. to EN 61 984		Surface	hard-silver plated
Cable diameter up to 7.5 mm		Contact resistance	≤ 1mΩ
-Rated current	40A	Crimp terminal	
-Rated voltage	690V	-mm ²	1.5-6mm ²
-Rated impulse voltage	8kV	-AWG	16-10
-Pollution degree	3		
Rated voltage acc. to UL	600V		
Rated current acc. to UL	40A		
Insulation resistance	≥ 10 ¹⁰ Ω		
Material	polycarbonate		
Limiting temperatures	-40°C ...+125°C		
Flammability acc. to UL 94	V0		
Mechanical working life			
- mating cycles	≥ 500		

Crimp terminal

Order crimp contacts separately



Insert	Designation	Order No.
Male	HMK-003-MC-V2	129 003 010 0504
Female	HMK-003-FC-V2	129 003 020 0504

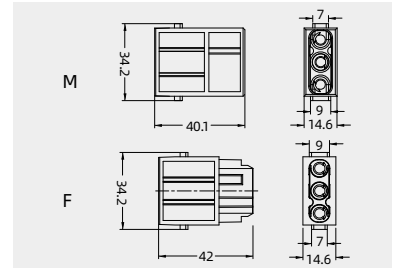

Crimp contacts

Crimp contacts 40A

Contact resistance ≤ 1 mΩ
silver plated



Male	Order No.	Female	Order No.
CCSM-1.5	101 023 110 0901	CCSF-1.5	101 023 120 0901
CCSM-2.5	101 023 110 1001	CCSF-2.5	101 023 120 1001
CCSM-4.0	101 023 110 1201	CCSF-4.0	101 023 120 1201
CCSM-6.0	101 023 110 1301	CCSF-6.0	101 023 120 1301
CCSM-10.0	101 023 110 1401	CCSF-10.0	101 023 120 1401

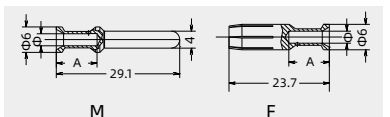

Wire gauge	φ	Stripping length
1.5 mm ²	AWG 16	1.75
2.5mm ²	AWG 14	2.25
4 mm ²	AWG 12	2.85
6 mm ²	AWG 10	3.5
10 mm ²	AWG 8	4.3
		12 mm

Stripping length A = 15 mm for cables ≥ 5 mm
Stripping length A = 18 mm for cables ≥ 6.4 mm

Tools

Crimping tool



Contact removal tool



Wire gauge	Designation	Order No.
1.5-6mm ²	TL02-0G	198 001 001 0012
4/6/10mm ²	TL02-3G	198 001 001 0013

Application	Designation	Order No.
for crimp contacts 40A	TL06G	198 001 000 0009

Notes: The tools for crimp terminal may influence the product quality and stability.
Please select the tools recognized by our company.

HMK-003/4 Crimp module

830/830V 40/10A



Combination with hinged frame and other modules possible.

Inserts

Technical characteristics

Specifications	DIN EN 60 664 DIN EN 61 984		
Approvals			
Inserts		Contacts	
Number of contacts	3/4	Material	copper alloy
Electrical data acc. to EN 61 984		Surface	hard-silver plated hard-gold plated
Power contacts		Contact resistance	
-Rated current	40A	-Power contacts	≤ 1mΩ
-Rated voltage	830V	-Signal contacts	≤ 3mΩ
-Rated impulse voltage	8kV	Crimp terminal	
-Pollution degree	3	- mm ²	
Signal contacts		-Power contacts	1.5-6mm ²
-Rated current	10A	-Signal contacts	0.14-2.5mm ²
-Rated voltage	830V	- AWG	
-Rated impulse voltage	8kV	-Power contacts	16-10
-Pollution degree	3	-Signal contacts	26-14
Rated voltage acc. to UL	600V	Max. insulation diameter	
Insulation resistance	≥ 10 ¹⁰ Ω	- Power contacts	5mm
Material	polycarbonate		
Limiting temperatures	-40°C ...+125°C		
Flammability acc. to UL 94	V0		
Mechanical working life	≥ 500		

Current carrying capacity

The current carrying is limited by maximum temperature of materials for inserts and contacts including terminals
Control and test procedures according to DIN EN 60512-5

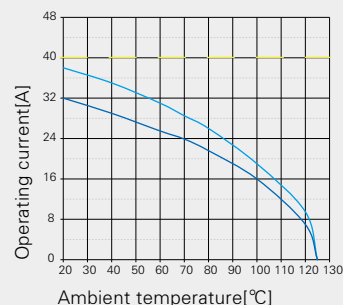

— 24 B hoods/housings with 6 modules, wire gauge: 6mm²
— 24 B hoods/housings with 6 modules, wire gauge: 4mm²

Crimp terminal

Order crimp contacts separately



Insert	Designation	Order No.
Male	HMK-003/4-MC	129 007 010 0001
Female	HMK-003/4-FC	129 007 020 0001

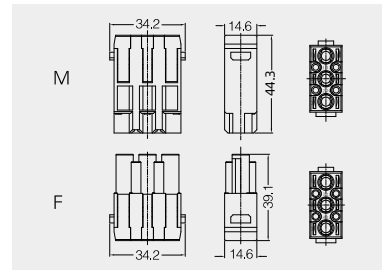

Crimp contacts

Crimp contacts 40A/10A

Contact resistance ≤ 1 mΩ silver plated



Male	Order No.	Female	Order No.
CCSM-1.5	101 023 110 0901	CCSF-1.5	101 023 120 0901
CCSM-2.5	101 023 110 1001	CCSF-2.5	101 023 120 1001
CCSM-4.0	101 023 110 1201	CCSF-4.0	101 023 120 1201
CCSM-6.0	101 023 110 1301	CCSF-6.0	101 023 120 1301
CCSM-10.0	101 023 110 1401	CCSF-10.0	101 023 120 1401

Contact resistance ≤ 3 mΩ silver plated



	Order No.		Order No.
CDSM-0.25	101 017 110 0101	CDSF-0.25	101 017 120 0101
CDSM-0.37	101 017 110 0301	CDSF-0.37	101 017 120 0301
CDSM-0.50	101 017 110 0401	CDSF-0.50	101 017 120 0401
CDSM-0.75	101 017 110 0601	CDSF-0.75	101 017 120 0601
CDSM-1.0	101 017 110 0801	CDSF-1.0	101 017 120 0801
CDSM-1.5	101 017 110 0901	CDSF-1.5	101 017 120 0901
CDSM-2.5	101 017 110 1001	CDSF-2.5	101 017 120 1001

Contact resistance ≤ 3mΩ gold plated



	Order No.		Order No.
CDGM-0.25	101 017 210 0101	CDGF-0.25	101 017 220 0101
CDGM-0.37	101 017 210 0301	CDGF-0.37	101 017 220 0301
CDGM-0.50	101 017 210 0401	CDGF-0.50	101 017 220 0401
CDGM-0.75	101 017 210 0601	CDGF-0.75	101 017 220 0601
CDGM-1.0	101 017 210 0801	CDGF-1.0	101 017 220 0801
CDGM-1.5	101 017 210 0901	CDGF-1.5	101 017 220 0901
CDGM-2.5	101 017 210 1001	CDGF-2.5	101 017 220 1001

More crimp contacts 10A see P13-02,P13-03.

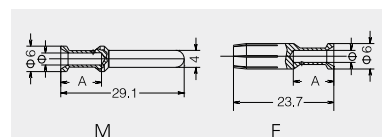

Wire gauge	Φ	Stripping length
1.5 mm ² AWG 16	1.75	9.6 mm
2.5mm ² AWG 14	2.25	9.6 mm
4 mm ² AWG 12	2.85	9.6 mm
6 mm ² AWG 10	3.5	9.6 mm

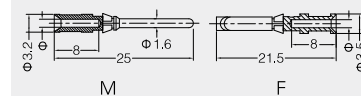

Wire gauge	Φ	Stripping length
0.09-0.25 mm ² AWG 28-24	0.65	5 mm
0.14-0.37 mm ² AWG 26-22	0.9	8 mm
0.5 mm ² AWG 20	1.1	8 mm
0.75 mm ² AWG 18	1.3	8 mm
1 mm ² AWG 18	1.45	8 mm
1.5 mm ² AWG 16	1.75	8 mm
2.5 mm ² AWG 14	2.25	6 mm

When the wire gauge is less than 0.75mm², it's better to use the auxiliary pin assembly tool TL16.

Notes: The tools for crimp terminal may influence the product quality and stability. Please select the tools recognized by our company.

*Please find the details of crimp contact tools on page 32-02~32-05.

HMK-004 Crimp module

830V 40A

Inserts



Combination with hinged frame and other modules possible.

Technical characteristics

Specifications	DIN EN 60 664 DIN EN 61 984		
Approvals			
Inserts		Contacts	
Number of contacts	4	Material	copper alloy
Electrical data acc. to EN 61 984		Surface	hard-silver plated
Rated current	40A	Contact resistance	≤ 1mΩ
Rated voltage	830V	Crimp terminal	
Rated impulse voltage	8kV	-mm ²	1.5-6mm ²
Pollution degree	3	-AWG	16-10
Rated voltage acc. to UL	600V		
Insulation resistance	≥ 10 ¹⁰ Ω		
Material	polycarbonate		
Limiting temperatures	-40°C ...+125°C		
Flammability acc. to UL 94	V0		
Mechanical working life			
- mating cycles	≥ 500		

Current carrying capacity

The current carrying is limited by maximum temperature of materials for inserts and contacts including terminals

Control and test procedures according to DIN EN 60512-5

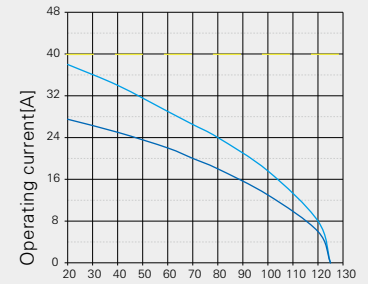

— 24 B hoods/housings with 6 modules, wire gauge: 6mm²
 — 24 B hoods/housings with 6 modules, wire gauge: 4mm²

Crimp terminal

Order crimp contacts separately



Insert	Designation	Order No.
Male	HMK-004-MC	129 004 010 0001
Female	HMK-004-FC	129 004 020 0001

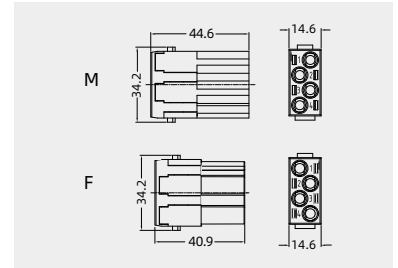

Crimp contacts

Crimp contacts 40A

Contact resistance ≤ 1 mΩ
silver plated



Male	Order No.	Female	Order No.
CCSM-1.5	101 023 110 0901	CCSF-1.5	101 023 120 0901
CCSM-2.5	101 023 110 1001	CCSF-2.5	101 023 120 1001
CCSM-4.0	101 023 110 1201	CCSF-4.0	101 023 120 1201
CCSM-6.0	101 023 110 1301	CCSF-6.0	101 023 120 1301

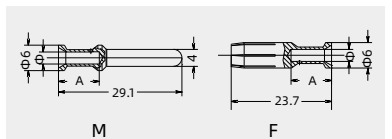

Wire gauge		Φ	Stripping length
1.5 mm ²	AWG 16	1.75	9.6 mm
2.5mm ²	AWG 14	2.25	9.6 mm
4 mm ²	AWG 12	2.85	9.6 mm
6 mm ²	AWG 10	3.5	9.6 mm

Stripping length A = 15 mm for cables ≥ 5 mm
 Stripping length A = 18 mm for cables ≥ 6.4 mm

Tools

Crimping tool



Contact removal tool



Wire gauge	Designation	Order No.
1.5-6mm ²	TL02-0G	198 001 001 0012
4/6/10mm ²	TL02-3G	198 001 001 0013

Application	Designation	Order No.
for crimp contacts 40A	TL06G	198 001 000 0009

Notes: The tools for crimp terminal may influence the product quality and stability. Please select the tools recognized by our company.

H2MVC-002 High voltage module

2900/5000V 40A

Inserts



Combination with hinged frame and other modules possible.
Only suitable for high structure shells.

Technical characteristics

Specifications	DIN EN 60 664 DIN EN 61 984		
Approvals			
Inserts		Contacts	
Number of contacts	2	Material	copper alloy
Electrical dataacc. to EN 61 984		Surface	hard-silver plated
-Rated current	40A	Contact resistance	≤ 1mΩ
-Rated voltage conductor(ground)	2900V	Crimp terminal	
-Rated voltage conductor(conductor)	5000V	-mm ²	1.5-10mm ²
-Rated impulse voltage	15kV	-AWG	16-8
-Pollution degree	3		
Insulation resistance	≥ 10 ¹⁰ Ω	Assembly instructions	
Material	polycarbonate/ PTFE		
Limiting temperatures	-40°C ...+125°C		Crimp with crimping tool • Snap crimped cable in the insert
Flammability acc. to UL 94	V0		shrink the heat shrink tube over the rear of contact
Max. cable diameter	9mm		
Mechanical working life			
- mating cycles	≥ 500		

Current carrying capacity

The current carrying is limited by maximum temperature of materials for inserts and contacts including terminals

Control and test procedures according to DIN EN 60512-5

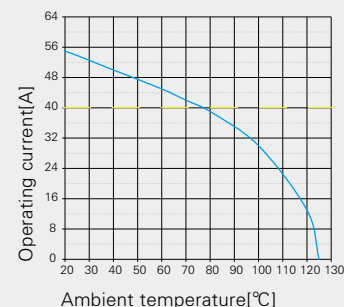

— 24 B hoods/housings with 3 modules, wire gauge: 6mm²

Crimp terminal

Order crimp contacts separately



Insert	Designation	Order No.
Male	H2MVC-002-MC	129 002 010 0401
Female	H2MVC-002-FC	129 002 020 0401

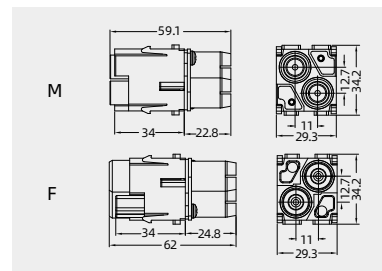

Crimp contacts

Crimp contacts 40A

Contact resistance ≤ 1 mΩ
silver plated



Male	Order No.	Female	Order No.
CCSM-1.5	101 023 110 0901	CCSF-1.5	101 023 120 0901
CCSM-2.5	101 023 110 1001	CCSF-2.5	101 023 120 1001
CCSM-4.0	101 023 110 1201	CCSF-4.0	101 023 120 1201
CCSM-6.0	101 023 110 1301	CCSF-6.0	101 023 120 1301
CCSM-10.0	101 023 110 1401	CCSF-10.0	101 023 120 1401

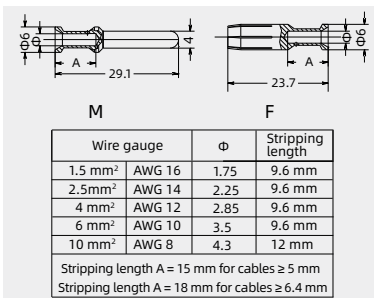

Tools

Crimping tool



Contact removal tool



Wire gauge	Designation	Order No.
1.5-6mm ²	TL02-0G	198 001 001 0012
4/6/10mm ²	TL02-3G	198 001 001 0013

Application	Designation	Order No.
for locking sleeve	TL10	198 001 000 0014

Notes: The tools for crimp terminal may influence the product quality and stability.
Please select the tools recognized by our company.

H2MVE-002 High voltage module

2900/5000V 16A

Inserts

Combination with hinged frame and other modules possible.
Only suitable for high structure shells.

Technical characteristics

Specifications	DIN EN 60 664 DIN EN 61 984		
Approvals			
Inserts		Contacts	
Number of contacts	2	Material	copper alloy
Electrical data acc. to EN 61 984		Surface	- hard-silver plated - hard-gold plated
-Rated current	16A	Contact resistance	≤ 1mΩ
-Rated voltage conductor(ground)	2900V	Crimp terminal	
-Rated voltage conductor(conductor)	5000V	-mm ²	0.5-4mm ²
-Rated impulse voltage	15kV	-AWG	20-12
-Pollution degree	3		
Insulation resistance	≥ 10 ¹⁰ Ω	Assembly instructions	
Material	polycarbonate/PTFE		
Limiting temperatures	-40°C ...+125°C		
Flammability acc. to UL 94	V0		
Mechanical working life			
Mechanical working life	≥ 500		

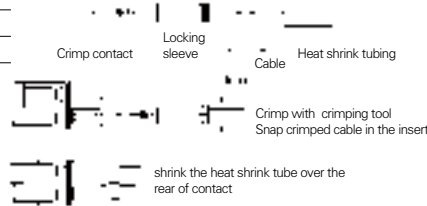

Current carrying capacity

The current carrying is limited by maximum temperature of materials for inserts and contacts including terminals

Control and test procedures according to DIN EN 60512-5

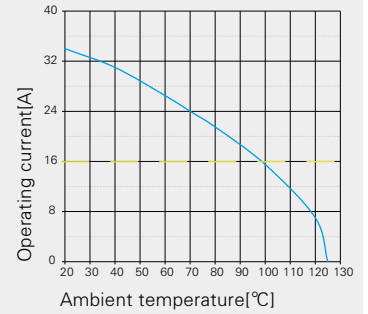

— 16 B hoods/housings with 1 module,
wire gauge: 2.5mm²

Crimp terminal

Order crimp contacts separately



Insert	Designation	Order No.
Male	H2MVE-002-MC	129 002 010 0301
Female	H2MVE-002-FC	129 002 020 0301

Crimp contacts

Crimp contacts 16A

Contact resistance ≤ 1mΩ
silver plated



gold plated



More crimp contacts 16A see P13-04.

Tools

Crimping tool



Male	Order No.	Female	Order No.
CESM-0.50	101 019 110 0401	CESF-0.50	101 019 120 0401
CESM-0.75	101 019 110 0601	CESF-0.75	101 019 120 0601
CESM-1.0	101 019 110 0801	CESF-1.0	101 019 120 0801
CESM-1.5	101 019 110 0901	CESF-1.5	101 019 120 0901
CESM-2.5	101 019 110 1001	CESF-2.5	101 019 120 1001
CESM-3.0	101 019 110 1101	CESF-3.0	101 019 120 1101
CESM-4.0	101 019 110 1201	CESF-4.0	101 019 120 1201
CEGM-0.50	101 019 210 0401	CEGF-0.50	101 019 220 0401
CEGM-0.75	101 019 210 0601	CEGF-0.75	101 019 220 0601
CEGM-1.0	101 019 210 0801	CEGF-1.0	101 019 220 0801
CEGM-1.5	101 019 210 0901	CEGF-1.5	101 019 220 0901
CEGM-2.5	101 019 210 1001	CEGF-2.5	101 019 220 1001
CEGM-3.0	101 019 210 1101	CEGF-3.0	101 019 220 1101
CEGM-4.0	101 019 210 1201	CEGF-4.0	101 019 220 1201

Wire gauge	Designation	Order No.
0.14-4mm ²	TL02G	198 001 001 0011
Application	Designation	Order No.
for locking sleeve	TL10	198 001 000 0014

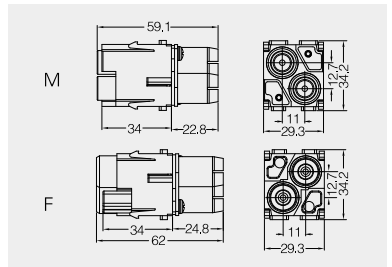

Identification	Wire gauge	Stripping length	
no groove	0.5 mm ²	AWG 20	7.5mm
1 groove	0.75 mm ²	AWG 18	7.5mm
1 groove	1 mm ²	AWG 18	7.5mm
2 grooves	1.5 mm ²	AWG 16	7.5mm
3 grooves	2.5 mm ²	AWG 14	7.5mm
wide groove	3 mm ²	AWG 12	7.5mm
no groove	4 mm ²	AWG 12	7.5mm

When the wire gauge is less than 0.75mm², it's better to use the auxiliary pin assembly tool TL15.

Notes: The tools for crimp terminal may influence the product quality and stability. Please select the tools recognized by our company.

HME-005 Screw module

230/400V 16A

Inserts



Combination with hinged frame and other modules possible.

Technical characteristics

Specifications	DIN EN 60 664 DIN EN 61 984		
Approvals	UL UL		
Inserts		Contacts	
Number of contacts	5	Material	copper alloy
Electrical data acc. to IEC 61984		Surface	hard-silver plated
Rated current	16A	Contact resistance	≤ 1mΩ
Rated voltage conductor -ground	230V	Screw terminal	
Rated voltage conductor - conductor	400V	-mm ²	0.5-4mm ²
Rated impulse voltage	4kV	-AWG	20-14
Pollution degree	3		
Insulation resistance	≥ 10 ¹⁰ Ω		
Material	polycarbonate		
Limiting temperatures	-40°C ...+125°C		
Flammability acc. to UL 94	V0		
Mechanical working life			
- mating cycles	≥ 500		

Current carrying capacity

The current carrying is limited by maximum temperature of materials for inserts and contacts including terminals

Control and test procedures according to DIN EN 60512-5

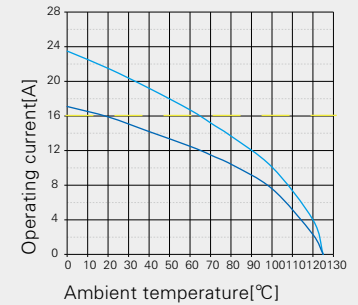

- 24 B hoods/housings with 6 modules, wire gauge: 2.5mm²
- 24 B hoods/housings with 6 modules, wire gauge: 1.5mm²

Screw terminal

Insert	Designation	Order No.
Male	HME-005-M	129 005 011 0001
Female	HME-005-F	129 005 021 0001

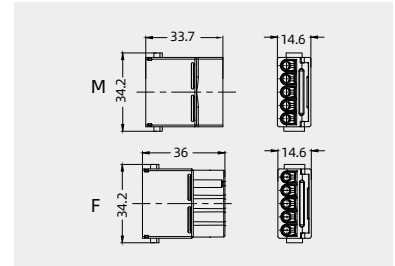

Assembly instructions

Step 1: remove the cover.

Step 2: install the wire from the top and fasten the side screw.

Step 3: put the cover on.

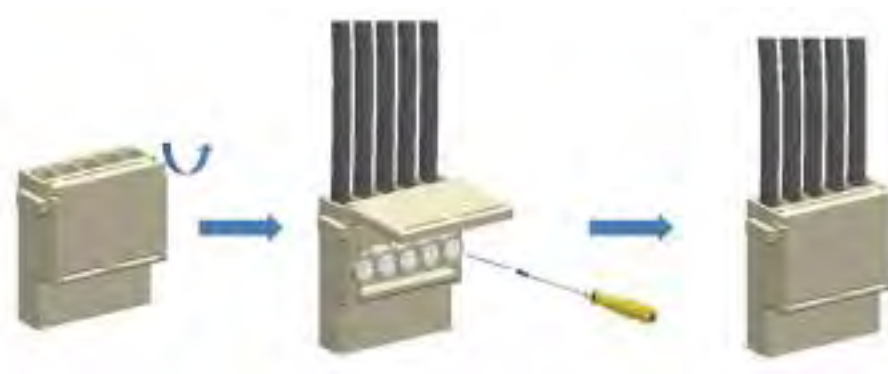

HME-005 Cage-clamp module

400V 16A

Inserts



Combination with hinged frame and other modules possible.

Technical characteristics

Specifications	DIN EN 60 664 DIN EN 61 984		
Approvals			
Inserts		Contacts	
Number of contacts	5	Material	copper alloy
Electrical data acc. to EN 61 984		Surface	hard-silver plated
-Rated current	16A	Contact resistance	≤ 3mΩ
-Rated voltage	400V	Cage clamp terminal	
-Rated impulse voltage	6kV	-mm ²	0.14-2.5mm ²
-Pollution degree	3	-AWG	26-14
Rated voltage acc. to UL	600V		
Insulation resistance	≥ 10 ¹⁰ Ω		
Material	polycarbonate		
Limiting temperatures	-40°C ... +125°C		
Flammability acc. to UL 94	V0		
Mechanical working life			
- mating cycles	≥ 500		

Current carrying capacity

The current carrying is limited by maximum temperature of materials for inserts and contacts including terminals

Control and test procedures according to DIN EN 60512-5

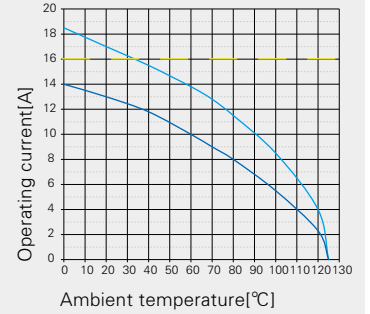

- 24 B hoods/housings with 6 modules, wire gauge: 2.5mm²
- 24 B hoods/housings with 6 modules, wire gauge: 1.5mm²

Cage-clamp terminal

See P00-14 for the structural characteristics of spring.



Insert	Designation	Order No.
Male	HME-005-MS	129 005 012 0001
Female	HME-005-FS	129 005 022 0001

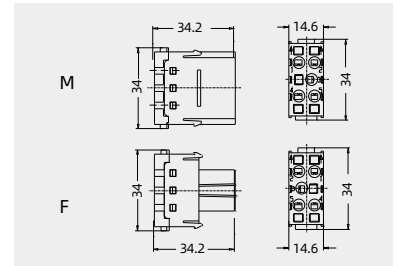

HME-006 Crimp module

500V 16A

Inserts



Combination with hinged frame and other modules possible.

Technical characteristics

Specifications	DIN EN 60 664 DIN EN 61 984		
Approvals			
Inserts		Contacts	
Number of contacts	6	Material	copper alloy
Electrical data acc. to EN 61 984		Surface	hard-silver plated hard-gold plated
Rated current	16A	Contact resistance	≤ 1mΩ
Rated voltage	500V	Crimp terminal	
Rated impulse voltage	6kV	-mm ²	0.14-4mm ²
Pollution degree	3	-AWG	26-12
Rated voltage acc. to UL	600V		
Insulation resistance	≥ 10 ¹⁰ Ω		
Material	polycarbonate		
Limiting temperatures	-40°C ...+125°C		
Flammability acc. to UL 94	V0		
Mechanical working life			
- mating cycles	≥ 500		

Current carrying capacity

The current carrying is limited by maximum temperature of materials for inserts and contacts including terminals

Control and test procedures according to DIN EN 60512-5

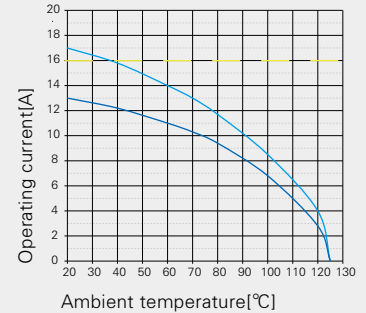

— 24 B hoods/housings with 6 modules, wire gauge: 2.5mm²
- - 24 B hoods/housings with 6 modules, wire gauge: 1.5mm²

Crimp terminal

Order crimp contacts separately



Insert	Designation	Order No.
Male	HME-006-MC	129 006 010 0001
Female	HME-006-FC	129 006 020 0001

Crimp contacts

Crimp contacts 16A

Contact resistance ≤ 1mΩ silver plated



gold plated



Male	Order No.	Female	Order No.
CESM-0.37	101 019 110 0301	CESF-0.37	101 019 120 0301
CESM-0.50	101 019 110 0401	CESF-0.50	101 019 120 0401
CESM-0.75	101 019 110 0601	CESF-0.75	101 019 120 0601
CESM-1.0	101 019 110 0801	CESF-1.0	101 019 120 0801
CESM-1.5	101 019 110 0901	CESF-1.5	101 019 120 0901
CESM-2.5	101 019 110 1001	CESF-2.5	101 019 120 1001
CESM-3.0	101 019 110 1101	CESF-3.0	101 019 120 1101
CESM-4.0	101 019 110 1201	CESF-4.0	101 019 120 1201
CEGM-0.37	101 019 210 0301	CEGF-0.37	101 019 220 0301
CEGM-0.50	101 019 210 0401	CEGF-0.50	101 019 220 0401
CEGM-0.75	101 019 210 0601	CEGF-0.75	101 019 220 0601
CEGM-1.0	101 019 210 0801	CEGF-1.0	101 019 220 0801
CEGM-1.5	101 019 210 0901	CEGF-1.5	101 019 220 0901
CEGM-2.5	101 019 210 1001	CEGF-2.5	101 019 220 1001
CEGM-3.0	101 019 210 1101	CEGF-3.0	101 019 220 1101
CEGM-4.0	101 019 210 1201	CEGF-4.0	101 019 220 1201

More crimp contacts 16A see P13-04.

Tools

Crimping tool



Contact removal tool



Wire gauge	Designation	Order No.
0.14-4mm ²	TL02G	198 001 001 0011
Wire gauge: 0.14-0.37mm ² please select TL02 Crimping tool.		
Application	Designation	Order No.
for crimp contacts 16A	TL01	198 001 000 0002

Notes: The tools for crimp terminal may influence the product quality and stability. Please select the tools recognized by our company.

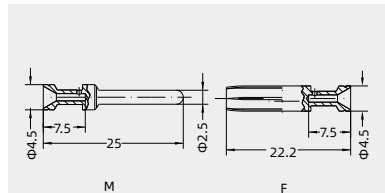
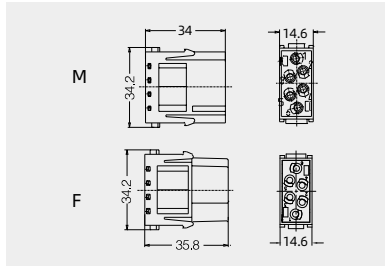

Identification	Wire gauge	Stripping length
no groove	0.14-0.37 mm ² AWG 26-22	7.5mm
no groove	0.5 mm ² AWG 20	7.5mm
1 groove	0.75 mm ² AWG 18	7.5mm
1 groove	1 mm ² AWG 18	7.5mm
2 grooves	1.5 mm ² AWG 16	7.5mm
3 grooves	2.5 mm ² AWG 14	7.5mm
wide groove	3 mm ² AWG 12	7.5mm
no groove	4 mm ² AWG 12	7.5mm

When the wire gauge is less than 0.75mm², it's better to use the auxiliary pin assembly tool TL15.

HME-006 Quick-in module

500V 16A

Inserts



Combination with hinged frame and other modules possible.

Technical characteristics

Specifications	DIN EN 60 664		
	DIN EN 61 984		
Approvals			
Inserts	Contacts		
No. of contact	6	Terminal	spring terminal(Quick-in)
Electrical data acc. to EN 61 984		Material	copper alloy
-Rated current	16A	Surface	hard-silver plated
-Rated voltage	500V	Contact resistance	$\leq 3m\Omega$
-Rated impulse voltage	6kV	Wire gauge	
-Pollution degree	3	-mm ²	0.5-4.0mm ²
Insulation resistance	$\geq 10^{10}\Omega$	-AWG	20-12
Material	polycarbonate	(For wires with crimped ferrule, wire gauge)	
Colour	RAL 7032(light grey)	-mm ²	0.14-2.5mm ²
Limiting temperatures	-40°C ...+125°C	-AWG	26-14
Flammability acc. to UL 94	V0	Stripping length	10±0.5mm
Mating cycles	≥ 500		

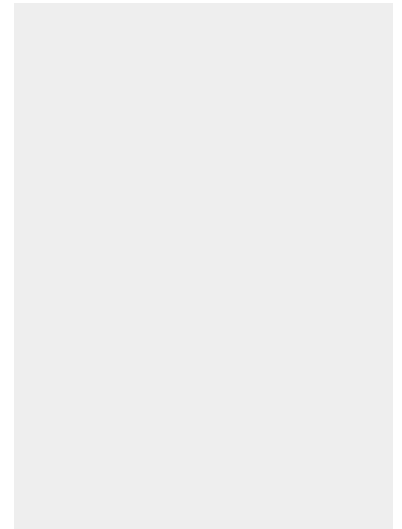

Spring terminal(Quick-in)



Insert	Designation	Order No.
Male	HME-006-MQ	129 006 010 0002
Female	HME-006-FQ	129 006 020 0002

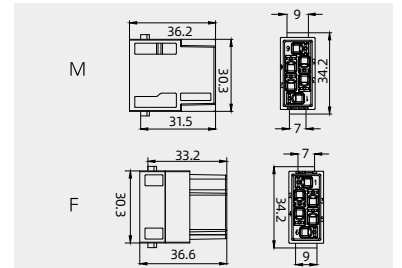

HVME-006 Protected module

830V 16A

Inserts



Combination with hinged frame and other modules possible.

Technical characteristics

Specifications	DIN EN 60 664 DIN EN 61 984		
Approvals			
Inserts		Contacts	
Number of contacts	6	Material	copper alloy
Electrical data acc. to EN 61 984		Surface	hard-silver plated hard-gold plated
-Rated current	16A	Contact resistance	≤ 1mΩ
-Rated voltage	830V	Crimp terminal	
-Rated impulse voltage	8kV	-mm ²	0.14-4mm ²
-Pollution degree	3	-AWG	26-12
Rated voltage acc. to UL	600V		
Insulation resistance	≥ 10 ¹⁰ Ω		
Material	polycarbonate		
Limiting temperatures	-40°C ...+125°C		
Flammability acc. to UL 94	V0		
Mechanical working life			
- mating cycles	≥ 500		

Current carrying capacity

The current carrying is limited by maximum temperature of materials for inserts and contacts including terminals

Control and test procedures according to DIN EN 60512-5

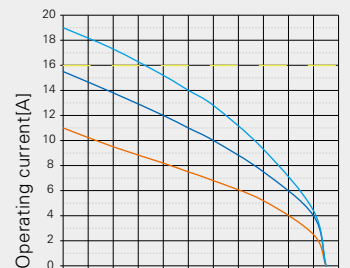

Ambient temperature[°C]

- 24 B hoods/housings with 6 modules, wire gauge: 4.0mm²
- 24 B hoods/housings with 6 modules, wire gauge: 2.5mm²
- 24 B hoods/housings with 6 modules, wire gauge: 1.5mm²

Crimp terminal

Order crimp contacts separately



Insert	Designation	Order No.
Male	HVME-006-MC	129 006 010 0101
Female	HVME-006-FC	129 006 020 0101

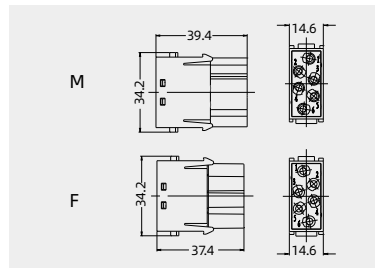

Crimp contacts

Crimp contacts 16A

Contact resistance ≤ 1mΩ
silver plated



gold plated



Male	Order No.	Female	Order No.
CESM-0.37	101 019 110 0301	CESF-0.37	101 019 120 0301
CESM-0.50	101 019 110 0401	CESF-0.50	101 019 120 0401
CESM-0.75	101 019 110 0601	CESF-0.75	101 019 120 0601
CESM-1.0	101 019 110 0801	CESF-1.0	101 019 120 0801
CESM-1.5	101 019 110 0901	CESF-1.5	101 019 120 0901
CESM-2.5	101 019 110 1001	CESF-2.5	101 019 120 1001
CESM-3.0	101 019 110 1101	CESF-3.0	101 019 120 1101
CESM-4.0	101 019 110 1201	CESF-4.0	101 019 120 1201
CEGM-0.37	101 019 210 0301	CEGF-0.37	101 019 220 0301
CEGM-0.50	101 019 210 0401	CEGF-0.50	101 019 220 0401
CEGM-0.75	101 019 210 0601	CEGF-0.75	101 019 220 0601
CEGM-1.0	101 019 210 0801	CEGF-1.0	101 019 220 0801
CEGM-1.5	101 019 210 0901	CEGF-1.5	101 019 220 0901
CEGM-2.5	101 019 210 1001	CEGF-2.5	101 019 220 1001
CEGM-3.0	101 019 210 1101	CEGF-3.0	101 019 220 1101
CEGM-4.0	101 019 210 1201	CEGF-4.0	101 019 220 1201

More crimp contacts 16A see P13-04.

Tools

Crimping tool



Contact removal tool



Wire gauge	Designation	Order No.
0.14-4mm ²	TL02G	198 001 001 0011
Wire gauge: 0.14-0.37mm ² please select TL02 Crimping tool.		
Application	Designation	Order No.
for crimp contacts 16A	TL01	198 001 000 0002

Identification	Wire gauge	Stripping length
no groove	0.14-0.37 mm ² AWG 26-22	7.5mm
no groove	0.5 mm ² AWG 20	7.5mm
1 groove	0.75 mm ² AWG 18	7.5mm
1 groove	1 mm ² AWG 18	7.5mm
2 grooves	1.5 mm ² AWG 16	7.5mm
3 grooves	2.5 mm ² AWG 14	7.5mm
wide groove	3 mm ² AWG 12	7.5mm
no groove	4 mm ² AWG 12	7.5mm

When the wire gauge is less than 0.75mm², it's better to use the auxiliary pin assembly tool TL15.

Notes: The tools for crimp terminal may influence the product quality and stability. Please select the tools recognized by our company.

HMEE-008 Crimp module

400V 16A

Inserts



Combination with hinged frame and other modules possible.

Technical characteristics

Specifications	DIN EN 60 664 DIN EN 61 984		
Approvals			
Inserts	Contacts		
Number of contacts	8	Material	copper alloy
Electrical data acc. to EN 61 984		Surface	hard-silver plated
-Rated current	16A		hard-gold plated
-Rated voltage	400V	Contact resistance	≤ 1mΩ
-Rated impulse voltage	6kV	Crimp terminal	
-Pollution degree	3	-mm ²	0.14-4mm ²
Rated voltage acc. to UL	600V	-AWG	26-12
Insulation resistance	≥ 10 ¹⁰ Ω		
Material	polycarbonate		
Limiting temperatures	-40°C ...+125°C		
Flammability acc. to UL 94	V0		
Mechanical working life			
- mating cycles	≥ 500		

Current carrying capacity

The current carrying is limited by maximum temperature of materials for inserts and contacts including terminals

Control and test procedures according to DIN EN 60512-5

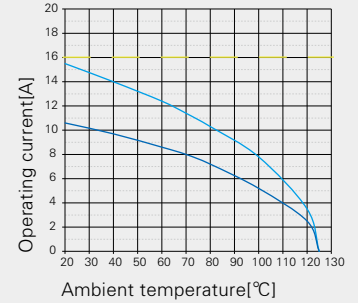

- 24 B hoods/housings with 6 modules, wire gauge: 2.5mm²
- 24 B hoods/housings with 6 modules, wire gauge: 1.5mm²

Crimp terminal

Order crimp contacts separately



Insert	Designation	Order No.
Male	HMEE-008-MC	129 008 010 0001
Female	HMEE-008-FC	129 008 020 0001

Crimp contacts

Crimp contacts 16A

Contact resistance ≤ 1mΩ silver plated



gold plated



Male	Order No.	Female	Order No.
CESM-0.37	101 019 110 0301	CESF-0.37	101 019 120 0301
CESM-0.50	101 019 110 0401	CESF-0.50	101 019 120 0401
CESM-0.75	101 019 110 0601	CESF-0.75	101 019 120 0601
CESM-1.0	101 019 110 0801	CESF-1.0	101 019 120 0801
CESM-1.5	101 019 110 0901	CESF-1.5	101 019 120 0901
CESM-2.5	101 019 110 1001	CESF-2.5	101 019 120 1001
CESM-3.0	101 019 110 1101	CESF-3.0	101 019 120 1101
CESM-4.0	101 019 110 1201	CESF-4.0	101 019 120 1201
CEGM-0.37	101 019 210 0301	CEGF-0.37	101 019 220 0301
CEGM-0.50	101 019 210 0401	CEGF-0.50	101 019 220 0401
CEGM-0.75	101 019 210 0601	CEGF-0.75	101 019 220 0601
CEGM-1.0	101 019 210 0801	CEGF-1.0	101 019 220 0801
CEGM-1.5	101 019 210 0901	CEGF-1.5	101 019 220 0901
CEGM-2.5	101 019 210 1001	CEGF-2.5	101 019 220 1001
CEGM-3.0	101 019 210 1101	CEGF-3.0	101 019 220 1101
CEGM-4.0	101 019 210 1201	CEGF-4.0	101 019 220 1201

More crimp contacts 16A see P13-04.

Tools

Crimping tool



Contact removal tool



Wire gauge	Designation	Order No.
0.14-4mm ²	TL02G	198 001 001 0011
Wire gauge: 0.14-0.37mm ² please select TL02 Crimping tool.		
Application	Designation	Order No.
for crimp contacts 16A	TL01	198 001 000 0002

Identification	Wire gauge	Stripping length
no groove	0.14-0.37 mm ² AWG 26-22	7.5mm
no groove	0.5 mm ² AWG 20	7.5mm
1 groove	0.75 mm ² AWG 18	7.5mm
1 groove	1 mm ² AWG 18	7.5mm
2 grooves	1.5 mm ² AWG 16	7.5mm
3 grooves	2.5 mm ² AWG 14	7.5mm
wide groove	3 mm ² AWG 12	7.5mm
no groove	4 mm ² AWG 12	7.5mm

When the wire gauge is less than 0.75mm², it's better to use the auxiliary pin assembly tool TL15.

Notes: The tools for crimp terminal may influence the product quality and stability. Please select the tools recognized by our company.

HMEE-008 Quick-in module

400V 16A

Inserts



Combination with hinged frame and other modules possible.

Technical characteristics

Specifications	DIN EN 60 664 DIN EN 61 984		
Approvals			
Inserts		Contacts	
No.of contact	8	Terminal	spring terminal(Quick-in)
-Rated current	16A	Material	copper alloy
-Rated voltage	400V	Surface	hard-silver plated
-Rated impulse voltage	6kV	Contact resistance	≤ 3mΩ
-Pollution degree	3	Wire gauge	
Insulation resistance	≥ 10 ¹⁰ Ω	-mm ²	0.5-4.0mm ²
Material	polycarbonate	-AWG	20-12
Colour	RAL 7032(light grey)	(For wires with crimped ferrule, wire gauge)	
Limiting temperatures	-40°C ...+125°C	-mm ²	0.14-2.5mm ²
Flammability acc. to UL 94	V0	-AWG	26-14
Mating cycles	≥ 500	Stripping length	10±0.5mm

Spring terminal(Quick-in)



Insert	Designation	Order No.
Male	HMEE-008-MQ	129 008 001 0001
Female	HMEE-008-FQ	129 008 002 0001

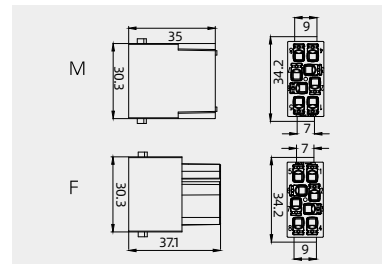

H2MEE-020 Crimp module

500V 16A

Inserts



Combination with hinged frame and other modules possible.

Technical characteristics

Specifications	DIN EN 60 664 DIN EN 61 984		
Approvals			
Inserts		Contacts	
Number of contacts	20	Material	copper alloy
Electrical data acc. to EN 61 984		Surface	hard-silver plated
-Rated current	16A		hard-gold plated
-Rated voltage	500V	Contact resistance	≤ 1mΩ
-Rated impulse voltage	6kV	Crimp terminal	
-Pollution degree	3	-mm ²	0.14-4mm ²
Rated voltage acc. to UL	600V	-AWG	26-12
Insulation resistance	≥ 10 ¹⁰ Ω		
Material	polycarbonate		
Limiting temperatures	-40°C ...+125°C		
Flammability acc. to UL 94	V0		
Mechanical working life			
- mating cycles	≥ 500		

Current carrying capacity

The current carrying is limited by maximum temperature of materials for inserts and contacts including terminals

Control and test procedures according to DIN EN 60512-5

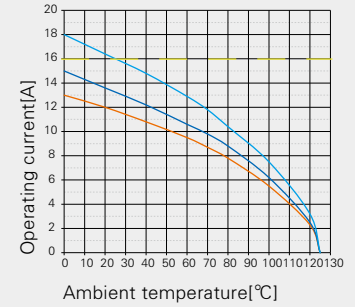

- 24 B hoods/housings with 3 modules, wire gauge: 4.0mm²
- 24 B hoods/housings with 3 modules, wire gauge: 2.5mm²
- 24 B hoods/housings with 3 modules, wire gauge: 1.5mm²

Crimp terminal

Order crimp contacts separately



Insert	Designation	Order No.
Male	H2MEE-020-MC	129 020 010 0001
Female	H2MEE-020-FC	129 020 020 0001

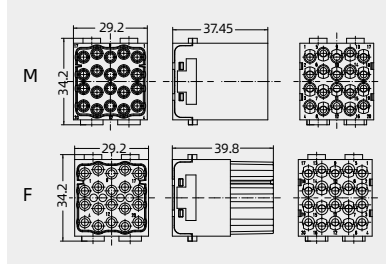

Crimp contacts

Crimp contacts 16A

Contact resistance ≤ 1mΩ silver plated



gold plated



Male	Order No.	Female	Order No.
CESM-0.37	101 019 110 0301	CESF-0.37	101 019 120 0301
CESM-0.50	101 019 110 0401	CESF-0.50	101 019 120 0401
CESM-0.75	101 019 110 0601	CESF-0.75	101 019 120 0601
CESM-1.0	101 019 110 0801	CESF-1.0	101 019 120 0801
CESM-1.5	101 019 110 0901	CESF-1.5	101 019 120 0901
CESM-2.5	101 019 110 1001	CESF-2.5	101 019 120 1001
CESM-3.0	101 019 110 1101	CESF-3.0	101 019 120 1101
CESM-4.0	101 019 110 1201	CESF-4.0	101 019 120 1201
CEGM-0.37	101 019 210 0301	CEGF-0.37	101 019 220 0301
CEGM-0.50	101 019 210 0401	CEGF-0.50	101 019 220 0401
CEGM-0.75	101 019 210 0601	CEGF-0.75	101 019 220 0601
CEGM-1.0	101 019 210 0801	CEGF-1.0	101 019 220 0801
CEGM-1.5	101 019 210 0901	CEGF-1.5	101 019 220 0901
CEGM-2.5	101 019 210 1001	CEGF-2.5	101 019 220 1001
CEGM-3.0	101 019 210 1101	CEGF-3.0	101 019 220 1101
CEGM-4.0	101 019 210 1201	CEGF-4.0	101 019 220 1201

More crimp contacts 16A see P13-04.

Tools

Crimping tool



Contact removal tool



Wire gauge	Designation	Order No.
0.14-4mm ²	TL02G	198 001 001 0011
Wire gauge: 0.14-0.37mm ² please select TL02 Crimping tool.		
Application	Designation	Order No.
for crimp contacts 16A	TL01	198 001 000 0002

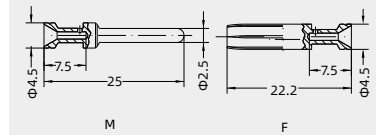

Identification	Wire gauge	Stripping length	
no groove	0.14-0.37 mm ²	AWG 26-22	7.5mm
no groove	0.5 mm ²	AWG 20	7.5mm
1 groove	0.75 mm ²	AWG 18	7.5mm
1 groove	1 mm ²	AWG 18	7.5mm
2 grooves	1.5 mm ²	AWG 16	7.5mm
3 grooves	2.5 mm ²	AWG 14	7.5mm
wide groove	3 mm ²	AWG 12	7.5mm
no groove	4 mm ²	AWG 12	7.5mm

When the wire gauge is less than 0.75mm², it's better to use the auxiliary pin assembly tool TL15.

Notes: The tools for crimp terminal may influence the product quality and stability. Please select the tools recognized by our company.

HMD-012 Crimp module

250V 10A

Inserts



Combination with hinged frame and other modules possible.

Technical characteristics

Specifications	DIN EN 60 664 DIN EN 61 984		
Approvals			
Inserts		Contacts	
Number of contacts	12	Material	copper alloy
Electrical data acc. to EN 61 984		Surface	hard-silver plated hard-gold plated
-Rated current	10A	Contact resistance	≤ 3mΩ
-Rated voltage	250V	Crimp terminal	
-Rated impulse voltage	4kV	-mm ²	0.14-2.5mm ²
-Pollution degree	3	-AWG	26-14
Rated voltage acc. to UL	600V		
Insulation resistance	≥ 10 ¹⁰ Ω		
Material	polycarbonate		
Limiting temperatures	-40°C ...+125°C		
Flammability acc. to UL 94	V0		
Mechanical working life			
- mating cycles	≥ 500		

Current carrying capacity

The current carrying is limited by maximum temperature of materials for inserts and contacts including terminals

Control and test procedures according to DIN EN 60512-5

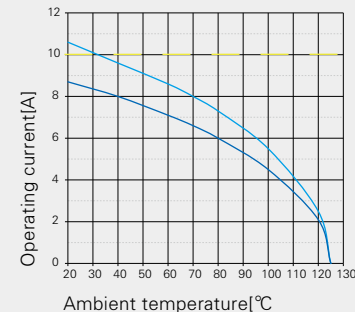

— 24 B hoods/housings with 6 modules, wire gauge: 1.5mm²
 — 24 B hoods/housings with 6 modules, wire gauge: 1.0mm²

Crimp terminal

Order crimp contacts separately



Insert	Designation	Order No.
Male	HMD-012-MC	129 012 010 0001
Female	HMD-012-FC	129 012 020 0001

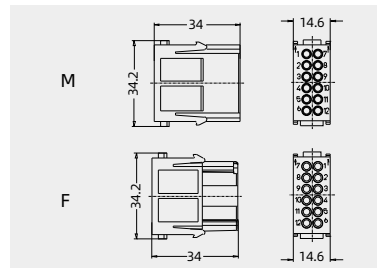

Crimp contacts

Crimp contacts 10A

Contact resistance ≤ 3mΩ silver plated



gold plated



Male	Order No.	Female	Order No.
CDSM-0.25	101 017 110 0101	CDSF-0.25	101 017 120 0101
CDSM-0.37	101 017 110 0301	CDSF-0.37	101 017 120 0301
CDSM-0.50	101 017 110 0401	CDSF-0.50	101 017 120 0401
CDSM-0.75	101 017 110 0601	CDSF-0.75	101 017 120 0601
CDSM-1.0	101 017 110 0801	CDSF-1.0	101 017 120 0801
CDSM-1.5	101 017 110 0901	CDSF-1.5	101 017 120 0901
CDSM-2.5	101 017 110 1001	CDSF-2.5	101 017 120 1001
CDGM-0.25	101 017 210 0101	CDGF-0.25	101 017 220 0101
CDGM-0.37	101 017 210 0301	CDGF-0.37	101 017 220 0301
CDGM-0.50	101 017 210 0401	CDGF-0.50	101 017 220 0401
CDGM-0.75	101 017 210 0601	CDGF-0.75	101 017 220 0601
CDGM-1.0	101 017 210 0801	CDGF-1.0	101 017 220 0801
CDGM-1.5	101 017 210 0901	CDGF-1.5	101 017 220 0901
CDGM-2.5	101 017 210 1001	CDGF-2.5	101 017 220 1001

More crimp contacts 10A see P13-02,P13-02.

Tools

Crimping tool



Contact removal tool



Wire gauge	Designation	Order No.
0.14-4mm ²	TL02G	198 001 001 0011
For the crimping contacts and removing contacts instructions, please find the page 06-23-06-24.		
Application	Designation	Order No.
for crimp contacts 10A	TL00	198 001 000 0001

More tools detail please find the page 32-03-32-06.

Wire gauge	Φ	Stripping length
0.09-0.25 mm ²	AWG 28-24	0.65 5 mm
0.14-0.37 mm ²	AWG 26-22	0.9 8 mm
0.5 mm ²	AWG 20	1.1 8 mm
0.75 mm ²	AWG 18	1.3 8 mm
1 mm ²	AWG 18	1.45 8 mm
1.5 mm ²	AWG 16	1.75 8 mm
2.5 mm ²	AWG 14	2.25 6 mm

When the wire gauge is less than 0.75mm², it's better to use the auxiliary pin assembly tool TL15.

Notes: The tools for crimp terminal may influence the product quality and stability. Please select the tools recognized by our company.

HMD-012 Quick-in module

250V 10A

Inserts



Combination with hinged frame and other modules possible.

Technical characteristics

Specifications	DIN EN 60 664 DIN EN 61 984		
Approvals			
Inserts	Contacts		
No. of contact	12	Terminal	Spring terminal(Quick-in)
Electrical data acc. to EN 61 984		Material	copper alloy
-Rated current	10A	Surface	hard-silver plated
-Rated voltage	250V	Contact resistance	≤ 3mΩ
-Rated impulse voltage	4kV	Wire gauge	
-Pollution degree	3	-mm ²	0.5-2.5mm ²
Rated voltage acc. to UL	250V	-AWG	20-14
Insulation resistance	≥ 10 ¹⁰ Ω	(For wires with crimped ferrule, wire gauge)	
Material	polycarbonate	-mm ²	0.14-1.5mm ²
Colour	RAL 7032(light grey)	-AWG	26-16
Limiting temperatures	-40°C ...+125°C	Stripping length	10±0.5mm
Flammability acc. to UL 94	V0		
Mating cycles	≥ 500		

Spring terminal(Quick-in)



Insert	Designation	Order No.
Male	HMD-012-MQ	129 012 001 0001
Female	HMD-012-FQ	129 012 002 0001

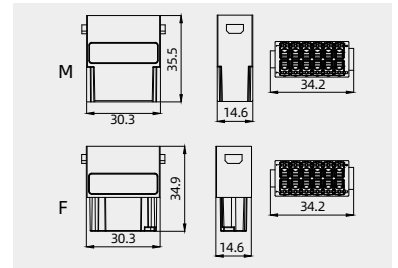

HMDD-017 Crimp module

160V 10A

Inserts



Combination with hinged frame and other modules possible.

Technical characteristics

Specifications	DIN EN 60 664 DIN EN 61 984		
Approvals			
Inserts		Contacts	
Number of contacts	17	Material	copper alloy
Electrical data acc. to EN 61 984		Surface	hard-silver plated
-Rated current	10A		hard-gold plated
-Rated voltage	160V	Contact resistance	≤ 3mΩ
-Rated impulse voltage	2.5kV	Crimp terminal	
-Pollution degree	3	-mm ²	0.14-2.5mm ²
Rated voltage acc. to UL	250V	-AWG	26-14
Insulation resistance	≥ 10 ¹⁰ Ω		
Material	polycarbonate		
Limiting temperatures	-40°C ...+125°C		
Flammability acc. to UL 94	V0		
Mechanical working life			
- mating cycle	≥ 500		

Current carrying capacity

The current carrying is limited by maximum temperature of materials for inserts and contacts including terminals

Control and test procedures according to DIN EN 60512-5

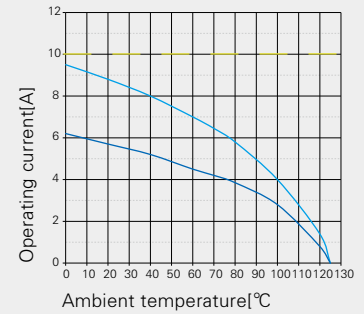

- 24 B hoods/housings with 6 modules, wire gauge: 1.5mm²
- 24 B hoods/housings with 6 modules, wire gauge: 1.0mm²

Crimp terminal

Order crimp contacts separately



Insert	Designation	Order No.
Male	HMDD-017-MC	129 017 010 0001
Female	HMDD-017-FC	129 017 020 0001

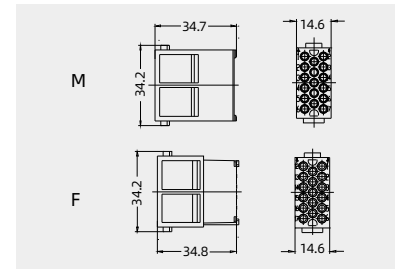

Crimp contacts

Crimp contacts 10A

Contact resistance ≤ 3mΩ silver plated



gold plated



More crimp contacts 10A see P13-02, P13-02.

Male	Order No.	Female	Order No.
CDSM-0.25	101 017 110 0101	CDSF-0.25	101 017 120 0101
CDSM-0.37	101 017 110 0301	CDSF-0.37	101 017 120 0301
CDSM-0.50	101 017 110 0401	CDSF-0.50	101 017 120 0401
CDSM-0.75	101 017 110 0601	CDSF-0.75	101 017 120 0601
CDSM-1.0	101 017 110 0801	CDSF-1.0	101 017 120 0801
CDSM-1.5	101 017 110 0901	CDSF-1.5	101 017 120 0901
CDSM-2.5	101 017 110 1001	CDSF-2.5	101 017 120 1001
CDGM-0.25	101 017 210 0101	CDGF-0.25	101 017 220 0101
CDGM-0.37	101 017 210 0301	CDGF-0.37	101 017 220 0301
CDGM-0.50	101 017 210 0401	CDGF-0.50	101 017 220 0401
CDGM-0.75	101 017 210 0601	CDGF-0.75	101 017 220 0601
CDGM-1.0	101 017 210 0801	CDGF-1.0	101 017 220 0801
CDGM-1.5	101 017 210 0901	CDGF-1.5	101 017 220 0901
CDGM-2.5	101 017 210 1001	CDGF-2.5	101 017 220 1001

Wire gauge	Φ	Stripping length	
0.09-0.25 mm ²	AWG 28-24	0.65	5 mm
0.14-0.37 mm ²	AWG 26-22	0.9	8 mm
0.5 mm ²	AWG 20	1.1	8 mm
0.75 mm ²	AWG 18	1.3	8 mm
1 mm ²	AWG 18	1.45	8 mm
1.5 mm ²	AWG 16	1.75	8 mm
2.5 mm ²	AWG 14	2.25	6 mm

When the wire gauge is less than 0.75mm², it's better to use the auxiliary pin assembly tool TL15.

Tools

Crimping tool



Contact removal tool



Wire gauge	Designation	Order No.
0.14-4mm ²	TL02G	198 001 001 0011
For the crimping contacts and removing contacts instructions, please find the page 06-23-06-24.		
Application	Designation	Order No.
for crimp contacts 10A	TL00	198 001 000 0001

More tools detail please find the page 32-03-32-06.

Notes: The tools for crimp terminal may influence the product quality and stability. Please select the tools recognized by our company.

H2MDD-042 Crimp module

150V 10A

Inserts



Combination with hinged frame and other modules possible.

Technical characteristics

Specifications	DIN EN 60 664 DIN EN 61 984		
Approvals			
Inserts		Contacts	
Number of contacts	42	Material	copper alloy
Electrical data acc. to EN 61 984		Surface	hard-silver plated
-Rated current	10A		hard-gold plated
-Rated voltage	150V	Contact resistance	≤ 3mΩ
-Rated impulse voltage	2.5kV	Crimp terminal	
-Pollution degree	3	-mm ²	0.14-2.5mm ²
Rated voltage acc. to UL	250V	-AWG	26-14
Insulation resistance	≥ 10 ¹⁰ Ω		
Material	polycarbonate		
Limiting temperatures	-40°C ...+125°C		
Flammability acc. to UL 94	V0		
Mechanical working life			
- mating cycles	≥ 500		

Crimp terminal

Order crimp contacts separately



Insert	Designation	Order No.
Male	H2MDD-042-MC	129 042 010 0001
Female	H2MDD-042-FC	129 042 020 0001

Crimp contacts

Crimp contacts 10A

Contact resistance ≤ 3mΩ
silver plated



Male	Order No.	Female	Order No.
CDSM-0.25	101 017 110 0101	CDSF-0.25	101 017 120 0101
CDSM-0.37	101 017 110 0301	CDSF-0.37	101 017 120 0301
CDSM-0.50	101 017 110 0401	CDSF-0.50	101 017 120 0401
CDSM-0.75	101 017 110 0601	CDSF-0.75	101 017 120 0601
CDSM-1.0	101 017 110 0801	CDSF-1.0	101 017 120 0801
CDSM-1.5	101 017 110 0901	CDSF-1.5	101 017 120 0901
CDSM-2.5	101 017 110 1001	CDSF-2.5	101 017 120 1001

gold plated



	Order No.		Order No.
CDGM-0.25	101 017 210 0101	CDGF-0.25	101 017 220 0101
CDGM-0.37	101 017 210 0301	CDGF-0.37	101 017 220 0301
CDGM-0.50	101 017 210 0401	CDGF-0.50	101 017 220 0401
CDGM-0.75	101 017 210 0601	CDGF-0.75	101 017 220 0601
CDGM-1.0	101 017 210 0801	CDGF-1.0	101 017 220 0801
CDGM-1.5	101 017 210 0901	CDGF-1.5	101 017 220 0901
CDGM-2.5	101 017 210 1001	CDGF-2.5	101 017 220 1001

More crimp contacts 10A
see P13-02,P13-02.

Tools

Crimping tool



Contact removal tool



Wire gauge	Designation	Order No.
0.14-4mm ²	TL02G	198 001 001 0011

For the crimping contacts and removing contacts instructions, please find the page 06-23-06-24.

Application	Designation	Order No.
for crimp contacts 10A	TL00	198 001 000 0001

More tools detail please find the page 32-03~32-06.

Notes: The tools for crimp terminal may influence the product quality and stability. Please select the tools recognized by our company.

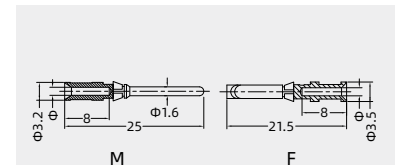
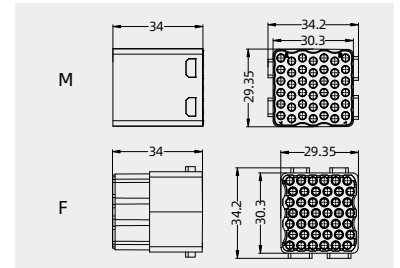
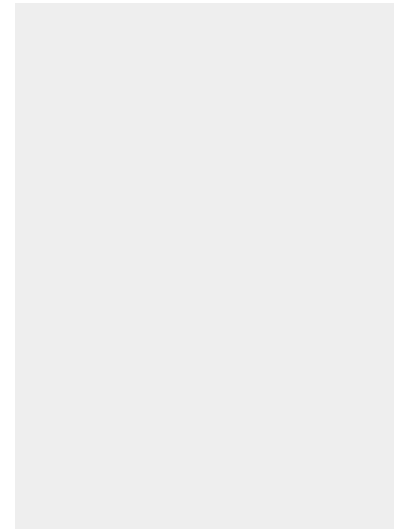

Wire gauge		φ	Stripping length
0.09-0.25 mm ²	AWG 28-24	0.65	5 mm
0.14-0.37 mm ²	AWG 26-22	0.9	8 mm
0.5 mm ²	AWG 20	1.1	8 mm
0.75 mm ²	AWG 18	1.3	8 mm
1 mm ²	AWG 18	1.45	8 mm
1.5 mm ²	AWG 16	1.75	8 mm
2.5 mm ²	AWG 14	2.25	6 mm

When the wire gauge is less than 0.75mm², it's better to use the auxiliary pin assembly tool TL15.

HMMB-008 MegaBit module

- Two outlet hole

50V 10A

Inserts



Only suitable for high constructure top entry hood/BK.
Combination with hinged frame and other modules possible.

Technical characteristics

Specifications	DIN EN 60 664 DIN EN 61 984		
Approvals			
Adapter module		MegaBit Insert	
Number of contacts	1	Contacts	2x4+shielding
Insulation resistance	$\geq 10^{10}\Omega$	Electrical dataacc. to EN 61 984	
Material	polycarbonate	-Rated current	10A
Limiting temperatures	-40°C ...+125°C	-Rated voltage	50V
Flammability acc. to UL 94	V0	-Rated impulse voltage	0.8kV
Mechanical working life		-Pollution degree	3
- mating cycle	≥ 500	Material	
Contacts		-insert	polycarbonate
Crimp terminal	hard-gold plated	-outer conductor	zinc alloy
-mm2	0.14-2.5 mm ²	Insulation resistance	$\leq 4m\Omega$
-AWG	26-14	Limiting temperatures	-40°C ...+85°C
		Flammability acc. to UL 94	V0
		Surface	passivated
		Clamping range	5-12 mm

MegaBit Insert, Crimp terminal
Order the adapter module separately.
Order crimp contacts separately.



Insert	Designation	Order No.
Male	HMMB-008-MC	129 008 010 0503
Female	HMMB-008-FC	129 008 020 0503

Adapter module



Insert	Designation	Order No.
Male	HMB.C-M	129 000 001 0001
Female	HMB.C-F	129 000 002 0001

Crimp contacts

Crimp contacts 10A

Contact resistance $\leq 3m\Omega$
silver plated



More crimp contacts 10A
see P13-02,P13-02.

Tools

Crimping tool



Contact removal tool



Male	Order No.	Female	Order No.
CDGM-0.25	101 017 210 0101	CDGF-0.25	101 017 220 0101
CDGM-0.37	101 017 210 0301	CDGF-0.37	101 017 220 0301
CDGM-0.50	101 017 210 0401	CDGF-0.50	101 017 220 0401
CDGM-0.75	101 017 210 0601	CDGF-0.75	101 017 220 0601
CDGM-1.0	101 017 210 0801	CDGF-1.0	101 017 220 0801
CDGM-1.5	101 017 210 0901	CDGF-1.5	101 017 220 0901
CDGM-2.5	101 017 210 1001	CDGF-2.5	101 017 220 1001

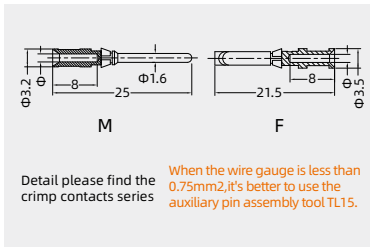
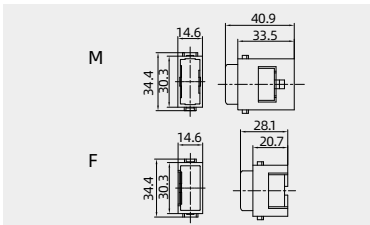
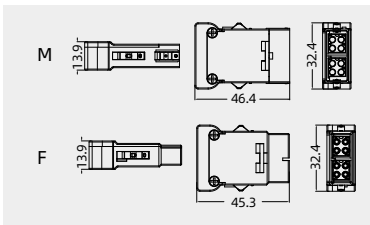
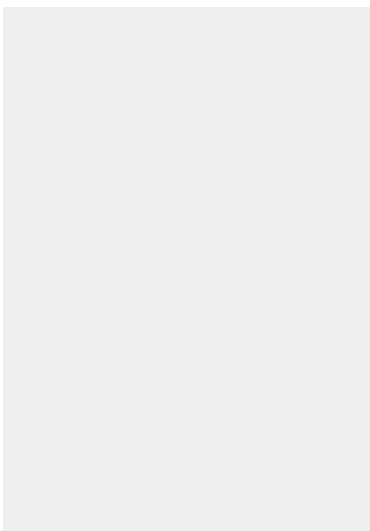

Notes: The tools for crimp terminal may influence the product quality and stability. Please select the tools recognized by our company.

HMMB/1-008 MegaBit module

- One outlet hole

50V 10A



Inserts



Only suitable for high constructure top entry hood/BK.
Combination with hinged frame and other modules possible.

Technical characteristics

Specifications	DIN EN 60 664 DIN EN 61 984
Approvals	
Adapter module	MegaBit Insert
Number of contacts	1
Insulation resistance	$\geq 10^{10}\Omega$
Material	polycarbonate
Limiting temperatures	-40°C ...+125°C
Flammability acc. to UL 94	V0
Mechanical working life	
- mating cycle	≥ 500
Contacts	
Material	copper alloy
Crimp terminal	hard-silver plated
	hard-gold plated
-mm ²	0.14-2.5 mm ²
-AWG	26-14
Contact resistance	$\leq 3m\Omega$
	MegaBit Insert
	Contacts 2x4
	Electrical dataacc. to EN 61 984
	-Rated current 10A
	-Rated voltage 50V
	-Rated impulse voltage 0.8kV
	-Pollution degree 3
	Material
	-insert polycarbonate
	-outer conductor Zinc alloy passivation
	Insulation resistance $\leq 4m\Omega$
	Limiting temperatures -40°C ...+85°C
	Flammability acc. to UL 94 V0
	Surface 钝化
	Clamping range 5-12 mm

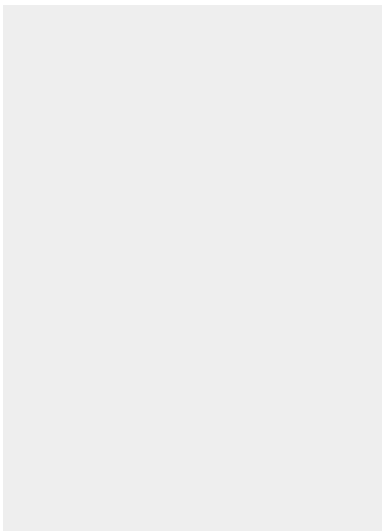

MegaBit Insert, Crimp terminal
Order the adapter module separately.
Order crimp contacts separately.



Insert	Designation	Order No.
Male	HMMB/1-008-MC	129 008 010 0511
Female	HMMB/1-008-FC	129 008 020 0511

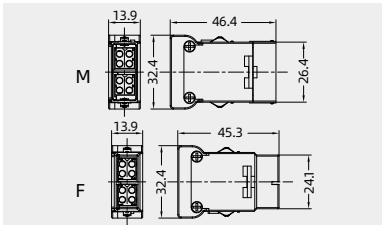

Adapter module



Insert	Designation	Order No.
Male	HMB.C-M	129 000 001 0001
Female	HMB.C-F	129 000 002 0001

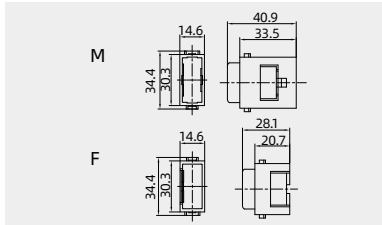

Crimp contacts

Crimp contacts 10A

Contact resistance $\leq 3m\Omega$
silver plated



More crimp contacts 10A
see P13-02,P13-02.

Tools

Crimping tool



Contact removal tool



Male	Order No.	Female	Order No.
CDGM-0.25	101 017 210 0101	CDGF-0.25	101 017 220 0101
CDGM-0.37	101 017 210 0301	CDGF-0.37	101 017 220 0301
CDGM-0.50	101 017 210 0401	CDGF-0.50	101 017 220 0401
CDGM-0.75	101 017 210 0601	CDGF-0.75	101 017 220 0601
CDGM-1.0	101 017 210 0801	CDGF-1.0	101 017 220 0801
CDGM-1.5	101 017 210 0901	CDGF-1.5	101 017 220 0901
CDGM-2.5	101 017 210 1001	CDGF-2.5	101 017 220 1001

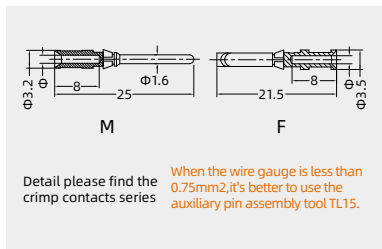

Wire gauge	Designation	Order No.
0.14-4mm ²	TL02G	198 001 001 0011
Application for crimp contacts 10A	Designation	Order No.
	TL00	198 001 000 0001

Notes: The tools for crimp terminal may influence the product quality and stability. Please select the tools recognized by our company.

HMGB-008 GigaBit module

50V 5A

Inserts



Only suitable for high constructure top entry hood/BK.
Combination with hinged frame and other modules possible.

Technical characteristics

Specifications	DIN EN 60 664 DIN EN 61 984		
Approvals			
Adapter module		GigaBit module	
Number of contacts	1	Contacts	8+shielding
Insulation resistance	$\geq 10^{10}\Omega$	Electrical dataacc. to EN 61 984	
Material	polycarbonate	-Rated current	5A
Limiting temperatures	-40°C ...+125°C	-Rated voltage	50V
Flammability acc. to UL 94	V0	-Rated impulse voltage	0.8kV
Mechanical working life		-Pollution degree	3
- mating cycle	≥ 500	Material	
D-Sub Contacts		-insert	polycarbonate
Crimp terminal	hard-gold plated	-outer conductor	zinc alloy
-mm ²	0.09-0.52 mm ²	Insulation resistance	$\leq 4m\Omega$
-AWG	28-20	Limiting temperatures	-40°C ...+85°C
		Flammability acc. to UL 94	V0
		Surface	passivated
		Clamping range	5-12 mm

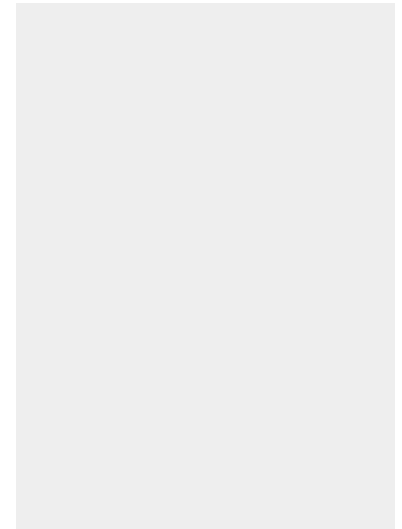

MegaBit Insert, Crimp terminal
Order the adapter module separately.
Order crimp contacts separately



Insert	Designation	Order No.
Male	HMGB-008-MC	129 008 010 0002
Female	HMGB-008-FC	129 008 020 0002

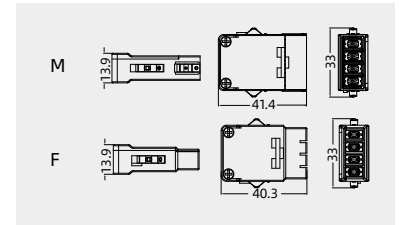

Order cable clamp separately.

Adapter module



Insert	Designation	Order No.
Male	HMB.C-M	129 000 001 0001
Female	HMB.C-F	129 000 002 0001

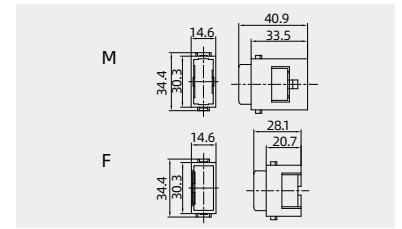

Crimp contacts

Crimp contacts 5A

Contact resistance $\leq 3m\Omega$
gold plated



Male	Order No.	Female	Order No.
CSGM-0.25	101 014 210 0101	CSGF-0.25	101 014 220 0101
CSGM-0.33	101 014 210 0201	CSGF-0.33	101 014 220 0201
CSGM-0.52	101 014 210 0501	CSGF-0.52	101 014 220 0501

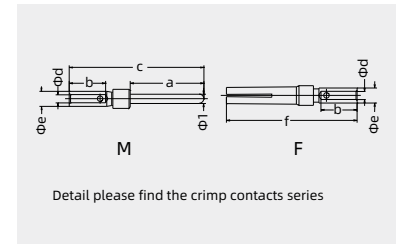

Detail please find the crimp contacts series

Tools

Crimping tool



Wire gauge	Designation	Order No.
0.09-0.82mm ²	TL03	198 001 001 0002

Notes: The tools for crimp terminal may influence the product quality and stability. Please select the tools recognized by our company.

HMMB-008 MegaBit module

- Two outlet hole

50V 10A

Inserts

Only suitable for high constructure top entry hood/BK.
Combination with hinged frame and other modules possible.

Technical characteristics

Specifications	DIN EN 60 664 DIN EN 61 984		
Approvals			
Adapter module		MegaBit Insert	
Number of contacts	1	Contacts	2x4+shielding
Insulation resistance	$\geq 10^{10}\Omega$	Electrical dataacc. to EN 61 984	
Material	polycarbonate	-Rated current	10A
Limiting temperatures	-40°C ...+125°C	-Rated voltage	50V
Flammability acc. to UL 94	V0	-Rated impulse voltage	0.8kV
Mechanical working life		-Pollution degree	3
- mating cycle	≥ 500	Material	
Contacts		-insert	polycarbonate
Crimp terminal	hard-gold plated	-outer conductor	zinc alloy
-mm ²	0.14-2.5 mm ²	Insulation resistance	$\leq 4m\Omega$
-AWG	26-14	Limiting temperatures	-40°C ...+85°C
		Flammability acc. to UL 94	V0
		Surface	passivated
		Clamping range	5-12 mm

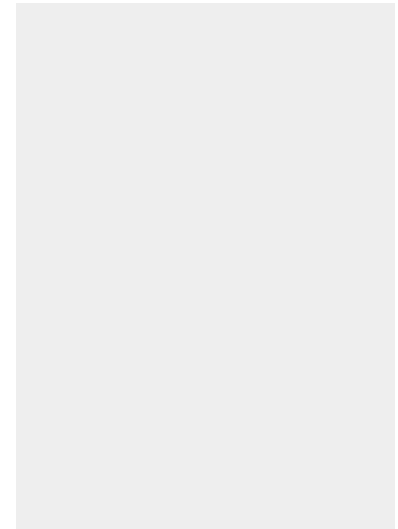

MegaBit Insert, Crimp terminal
Order the adapter module separately.
Order crimp contacts separately



Insert	Designation	Order No.
Male	HMMB-008-MC 3SP	129 008 010 0508
Female	HMMB-008-FC 3SP	129 008 020 0508

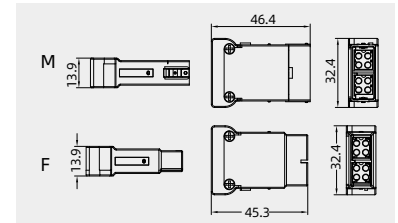

Adapter module



Insert	Designation	Order No.
Male	HMB.C-M	129 000 001 0001
Female	HMB.C-F	129 000 002 0001

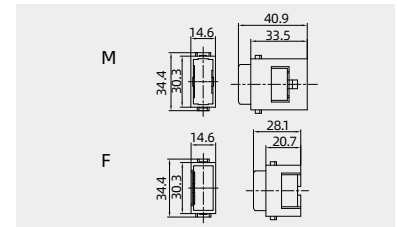

Crimp contacts

Crimp contacts 10A

Contact resistance $\leq 3m\Omega$
silver plated



Male	Order No.	Female	Order No.
CDGM-0.25	101 017 210 0101	CDGF-0.25	101 017 220 0101
CDGM-0.37	101 017 210 0301	CDGF-0.37	101 017 220 0301
CDGM-0.50	101 017 210 0401	CDGF-0.50	101 017 220 0401
CDGM-0.75	101 017 210 0601	CDGF-0.75	101 017 220 0601
CDGM-1.0	101 017 210 0801	CDGF-1.0	101 017 220 0801
CDGM-1.5	101 017 210 0901	CDGF-1.5	101 017 220 0901
CDGM-2.5	101 017 210 1001	CDGF-2.5	101 017 220 1001

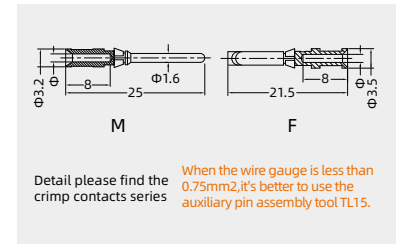

More crimp contacts 10A
see P13-02,P13-02.

Tools

Crimping tool



Contact removal tool



Wire gauge	Designation	Order No.
0.14-4mm ²	TL02G	198 001 001 0011

Application	Designation	Order No.
for crimp contacts 10A	TL00	198 001 000 0001

Notes: The tools for crimp terminal may influence the product quality and stability. Please select the tools recognized by our company.

HMMB/1-008 MegaBit module

- One outlet hole

50V 10A



Only suitable for high constructure top entry hood/BK. Combination with hinged frame and other modules possible.

Inserts

Technical characteristics

Specifications	DIN EN 60 664 DIN EN 61 984
Approvals	
Adapter module	MegaBit Insert
Number of contacts	1
Insulation resistance	$\geq 10^{10}\Omega$
Material	polycarbonate
Limiting temperatures	-40°C ...+125°C
Flammability acc. to UL 94	V0
Mechanical working life	
- mating cycle	≥ 500
Contacts	
Material	copper alloy
Crimp terminal	hard-silver plated
	hard-gold plated
-mm ²	0.14-2.5 mm ²
-AWG	26-14
Contact resistance	$\leq 3m\Omega$
MegaBit Insert	
Contacts	2x4
Electrical dataacc. to EN 61 984	
-Rated current	10A
-Rated voltage	50V
-Rated impulse voltage	0.8kV
-Pollution degree	3
Material	
-insert	polycarbonate
-outer conductor	Zinc alloy passivation
Insulation resistance	$\leq 4m\Omega$
Limiting temperatures	-40°C ...+85°C
Flammability acc. to UL 94	V0
Surface	钝化
Clamping range	5-12 mm

MegaBit Insert, Crimp terminal

Order the adapter module separately.

Order crimp contacts separately



Insert	Designation	Order No.
Male	HMMB/1-008-MC 3SP	129 008 010 0510
Female	HMMB/1-008-FC 3SP	129 008 020 0510

Not allow to connect with the frame shield
Order cable clamp separately.

Adapter module



Insert	Designation	Order No.
Male	HMB.C-M	129 000 001 0001
Female	HMB.C-F	129 000 002 0001

Crimp contacts

Crimp contacts 10A

Contact resistance $\leq 3m\Omega$
silver plated



More crimp contacts 10A
see P13-02,P13-02.

Tools

Crimping tool



Contact removal tool



Male	Order No.	Female	Order No.
CDGM-0.25	101 017 210 0101	CDGF-0.25	101 017 220 0101
CDGM-0.37	101 017 210 0301	CDGF-0.37	101 017 220 0301
CDGM-0.50	101 017 210 0401	CDGF-0.50	101 017 220 0401
CDGM-0.75	101 017 210 0601	CDGF-0.75	101 017 220 0601
CDGM-1.0	101 017 210 0801	CDGF-1.0	101 017 220 0801
CDGM-1.5	101 017 210 0901	CDGF-1.5	101 017 220 0901
CDGM-2.5	101 017 210 1001	CDGF-2.5	101 017 220 1001

Wire gauge	Designation	Order No.
0.14-4mm ²	TL02G	198 001 001 0011

Application	Designation	Order No.
for crimp contacts 10A	TL00	198 001 000 0001

Notes: The tools for crimp terminal may influence the product quality and stability. Please select the tools recognized by our company.

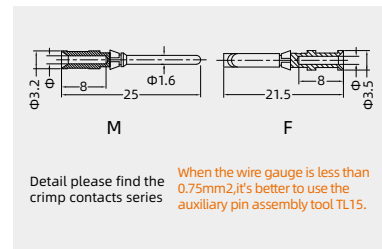
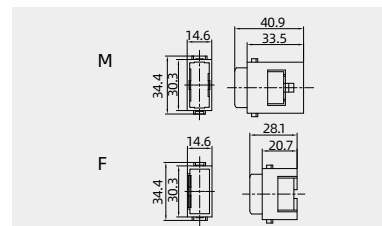
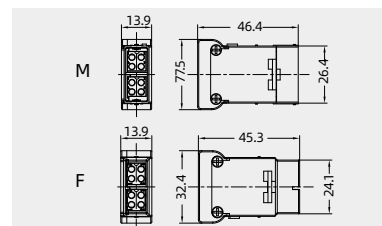
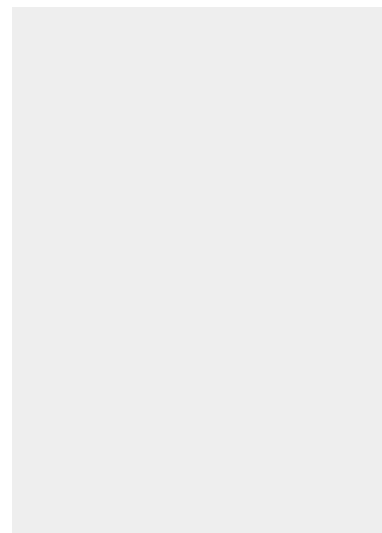

HMGB-008 GigaBit module

50V 5A

Inserts

Only suitable for high constructure top entry hood/BK.
Combination with hinged frame and other modules possible.

Technical characteristics

Specifications	DIN EN 60 664 DIN EN 61 984		
Approvals			
Adapter module		GigaBit module	
Number of contacts	1	Contacts	8+shielding
Insulation resistance	$\geq 10^{10}\Omega$	Electrical dataacc. to EN 61 984	
Material	polycarbonate	-Rated current	5A
Limiting temperatures	-40°C ...+125°C	-Rated voltage	50V
Flammability acc. to UL 94	V0	-Rated impulse voltage	0.8kV
Mechanical working life		-Pollution degree	3
- mating cycle	≥ 500	Material	
D-Sub Contacts		-insert	polycarbonate
Crimp terminal	hard-gold plated	-outer conductor	zinc alloy
-mm ²	0.09-0.52 mm ²	Insulation resistance	$\leq 4m\Omega$
-AWG	28-20	Limiting temperatures	-40°C ...+85°C
		Flammability acc. to UL 94	V0
		Surface	passivated
		Clamping range	5-12 mm

MegaBit Insert, Crimp terminal
Order the adapter module separately.
Order crimp contacts separately



Insert	Designation	Order No.
Male	HMGB-008-MC 3SP	129 008 010 0004
Female	HMGB-008-FC 3SP	129 008 020 0004

Not allow to connect with the frame shield
Order cable clamp separately.

Adapter module



Insert	Designation	Order No.
Male	HMB.C-M	129 000 001 0001
Female	HMB.C-F	129 000 002 0001

Crimp contacts

Crimp contacts 5A

Contact resistance $\leq 3m\Omega$
gold plated



Male	Order No.	Female	Order No.
CSGM-0.25	101 014 210 0101	CSGF-0.25	101 014 220 0101
CSGM-0.33	101 014 210 0201	CSGF-0.33	101 014 220 0201
CSGM-0.52	101 014 210 0501	CSGF-0.52	101 014 220 0501

Tools

Crimping tool



Wire gauge	Designation	Order No.
0.09-0.82mm ²	TL03	198 001 001 0002

Notes: The tools for crimp terminal may influence the product quality and stability. Please select the tools recognized by our company.

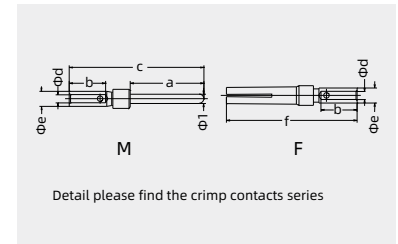
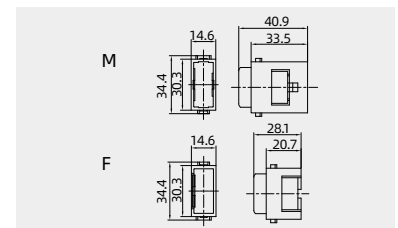
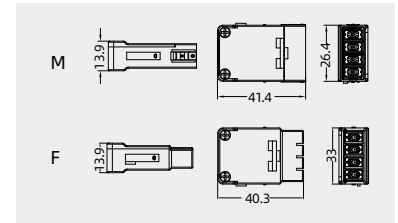
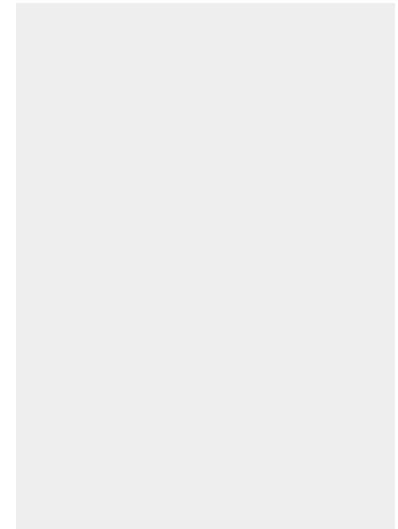

HMSB-024 Shielding Module

32V 4A

Inserts



Only suitable for high construction top entry hood/BK.
Combination with hinged frame and other modules possible.

Technical characteristics

Specifications	DIN EN 60 664 DIN EN 61 984		
Approvals		HMSB-024 module	
Adapter module		Contacts	24+shielding
Number of contacts	1	Electrical data acc. to EN 61 984	
Insulation resistance	$\geq 10^{10}\Omega$	-Rated current	4A
Material	polycarbonate	-Rated voltage	32V
Limiting temperatures	-40°C ... +125°C	-Rated impulse voltage	0.8kV
Flammability acc. to UL 94	V0	-Pollution degree	3
Mechanical working life		Material	
- mating cycle	≥ 500	-insert	polycarbonate
Contacts		-outer conductor	zinc alloy
Crimp terminal	hard-gold plated	Insulation resistance	$\leq 4m\Omega$
-mm ²	0.09-0.52 mm ²	Limiting temperatures	-40°C ... +85°C
-AWG	28-20	Flammability acc. to UL 94	V0
		Surface	passivated
		Clamping range	5-12 mm

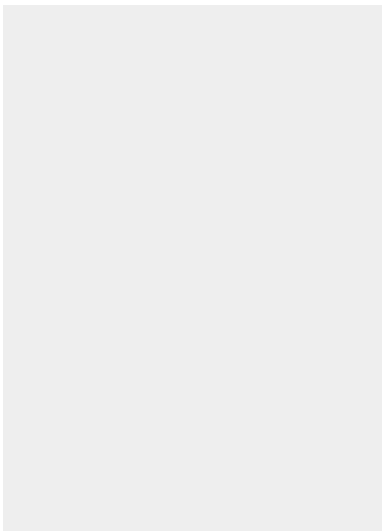

MegaBit Insert, Crimp terminal
Order the adapter module separately.
Order crimp contacts separately



Insert	Designation	Order No.
Male	HMSB-024-MC	129 024 010 0001
Female	HMSB-024-FC	129 024 020 0001

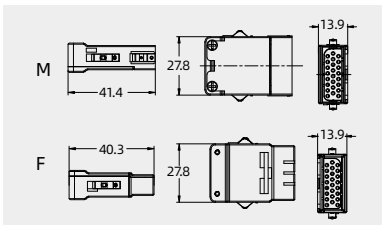

Adapter module



Insert	Designation	Order No.
Male	HMSB.C-M	129 000 011 1001
Female	HMSB.C-F	129 000 021 1001

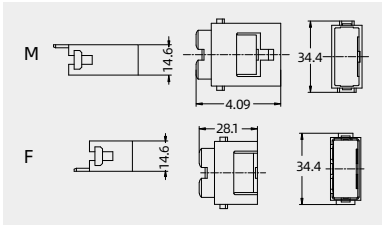

Crimp contacts

Crimp contacts 5A

Contact resistance $\leq 3m\Omega$
gold plated



Male	Order No.	Female	Order No.
CSGM-0.25	101 014 210 0101	CSGF-0.25	101 014 220 0101
CSGM-0.33	101 014 210 0201	CSGF-0.33	101 014 220 0201
CSGM-0.52	101 014 210 0501	CSGF-0.52	101 014 220 0501

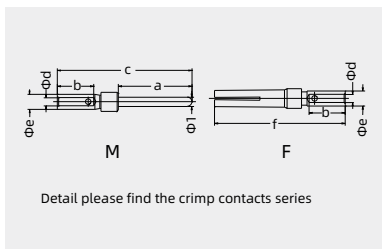

Tools

Crimping tool



Wire gauge	Designation	Order No.
0.09-0.82mm ²	TL03	198 001 001 0002

Notes: The tools for crimp terminal may influence the product quality and stability. Please select the tools recognized by our company.

Cable clamp

-Accessories for GigaBit, MegaBit and HMSB-024 shielding module



Technical characteristics

Specifications	DIN EN 60 664 DIN EN 61 984
Cable clamp	
Material	zinc alloy
Surface	passivated
Clamping range	5-14mm

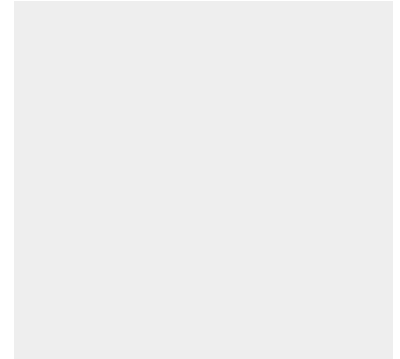

Cable clamp



Clamping range	Designation	Order No.
5-7 mm	HM-CLP5-7	198 002 003 0031

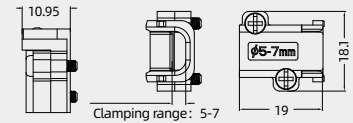

Cable clamp



Clamping range	Designation	Order No.
7-10 mm	HM-CLP7-10	198 002 003 0032

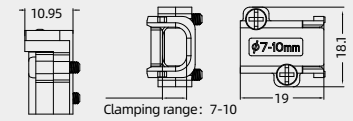

Cable clamp

Not applicable to HMMB with two outlet module



Clamping range	Designation	Order No.
9-11 mm	HM-CLP9-11	198 002 003 0037

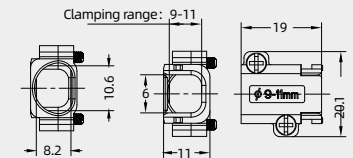

Cable clamp



Clamping range	Designation	Order No.
10-12 mm	HM-CLP10-12	198 002 003 0033

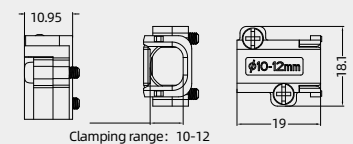

Cable clamp

Not applicable to HMMB with two outlet module



Clamping range	Designation	Order No.
11-14 mm	HM-CLP11-14	198 002 003 0044

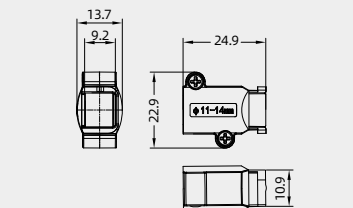

HMDS-009 D-Sub module
- for one cable

50V 5A

Inserts



Combination with hinged frame and other modules possible.

Technical characteristics

Specifications	DIN EN 60 664 DIN EN 61 984		
Approvals	CE ENEC		
Inserts		Contacts	
Number of contacts	9	Material	copper alloy
Electrical data acc. to EN 61 984		Surface	hard-silver plated
-Rated current	5A		hard-gold plated
-Rated voltage	50V	Contact resistance	≤ 3mΩ
-Rated impulse voltage	0.8kV	Crimp terminal	
-Pollution degree	3	-mm ²	0.09-0.82mm ²
Insulation resistance	≥ 10 ¹⁰ Ω	-AWG	28-18
Material	polycarbonate		
Limiting temperatures	-40°C ...+125°C		
Flammability acc. to UL 94	V0		
Mechanical working life			
- mating cycles	≥ 500		

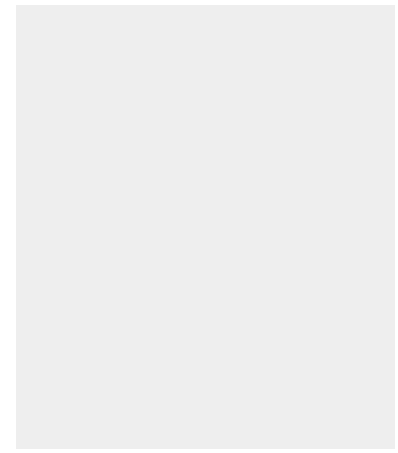

Crimp terminal

Order crimp contacts separately



Insert	Description	Designation	Order No.
Male	for one cable	HMDS/2.1-009-MC	129 009 010 0101
Female	for one cable	HMDS/2.1-009-FC	129 009 020 0101

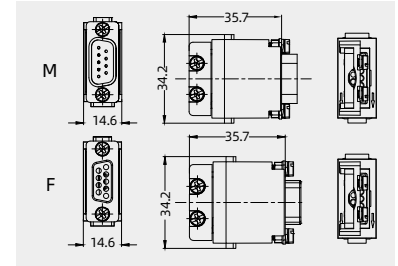

Crimp terminal

Order crimp contacts separately



Insert	Description	Designation	Order No.
Male	for one cable	HMDS/2.1-009-MC 3SP01	129 009 010 0506
Female	for one cable	HMDS/2.1-009-FC 3SP01	129 009 020 0506

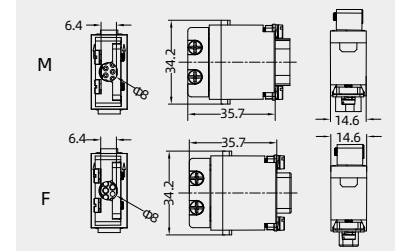

Clamp locking range: Φ 7mm

Crimp contacts

Crimp contacts 5A

Contact resistance ≤ 3mΩ
silver plated



Male	Order No.	Female	Order No.
CSSM-0.25	101 014 110 0101	CSSF-0.25	101 014 120 0101
CSSM-0.33	101 014 110 0201	CSSF-0.33	101 014 120 0201
CSSM-0.52	101 014 110 0501	CSSF-0.52	101 014 120 0501
CSSM-0.82	101 014 110 0701	CSSF-0.82	101 014 120 0701

gold plated



Male	Order No.	Female	Order No.
CSGM-0.25	101 014 210 0101	CSGF-0.25	101 014 220 0101
CSGM-0.33	101 014 210 0201	CSGF-0.33	101 014 220 0201
CSGM-0.52	101 014 210 0501	CSGF-0.52	101 014 220 0501
CSGM-0.82	101 014 210 0701	CSGF-0.82	101 014 220 0701

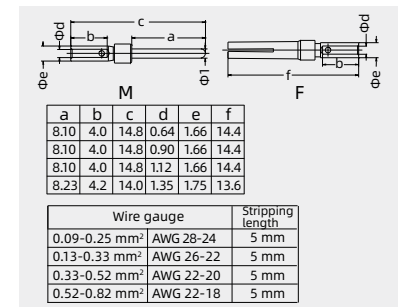

Tools

Crimping tool



Contact removal tool



Wire gauge	Designation	Order No.
0.09-0.82mm ²	TL03	198 001 001 0002

Application	Designation	Order No.
for 5A crimp contact	TL08	198 001 000 0006

Notes: The tools for crimp terminal may influence the product quality and stability. Please select the tools recognized by our company.

HMDS-009 D-Sub module - for two cables

50V 5A

Inserts



Combination with hinged frame and other modules possible.

Technical characteristics

Specifications	DIN EN 60 664 DIN EN 61 984		
Approvals			
Inserts		Contacts	
Number of contacts	9	Material	copper alloy
Electrical data acc. to EN 61 984		Surface	hard-silver plated
-Rated current	5A		hard-gold plated
-Rated voltage	50V	Contact resistance	≤ 3mΩ
-Rated impulse voltage	0.8kV	Crimp terminal	
-Pollution degree	3	-mm ²	0.09-0.82mm ²
Insulation resistance	≥ 10 ¹⁰ Ω	-AWG	28-18
Material	polycarbonate		
Limiting temperatures	-40°C ...+125°C		
Flammability acc. to UL 94	V0		
Mechanical working life			
- mating cycles	≥ 500		

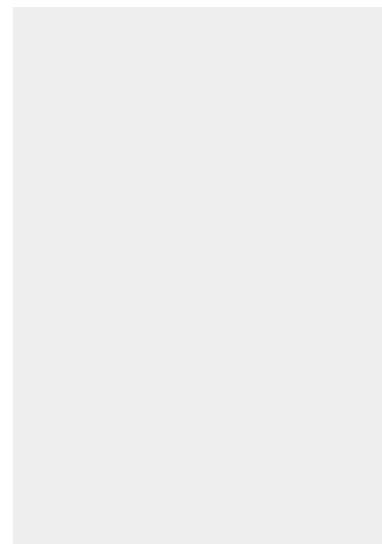

Crimp terminal

Order crimp contacts separately



Insert	Description	Designation	Order No.
Male	for two cables	HMDS/2.2-009-MC	129 009 010 0102
Female	for two cables	HMDS/2.2-009-FC	129 009 020 0102

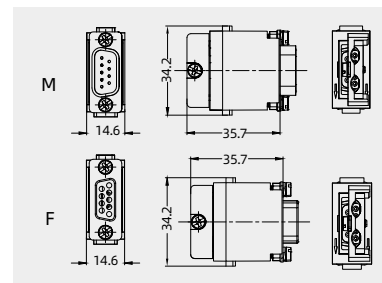

Crimp contacts

Crimp contacts 5A

Contact resistance ≤ 3mΩ
silver plated

gold plated



Male	Order No.	Female	Order No.
CSSM-0.25	101 014 110 0101	CSSF-0.25	101 014 120 0101
CSSM-0.33	101 014 110 0201	CSSF-0.33	101 014 120 0201
CSSM-0.52	101 014 110 0501	CSSF-0.52	101 014 120 0501
CSSM-0.82	101 014 110 0701	CSSF-0.82	101 014 120 0701
CSGM-0.25	101 014 210 0101	CSGF-0.25	101 014 220 0101
CSGM-0.33	101 014 210 0201	CSGF-0.33	101 014 220 0201
CSGM-0.52	101 014 210 0501	CSGF-0.52	101 014 220 0501
CSGM-0.82	101 014 210 0701	CSGF-0.82	101 014 220 0701

a	b	c	d	e	f
8.10	4.0	14.8	0.64	1.66	14.4
8.10	4.0	14.8	0.90	1.66	14.4
8.10	4.0	14.8	1.12	1.66	14.4
8.23	4.2	14.0	1.35	1.75	13.6

Wire gauge	Stripping length
0.09-0.25 mm ²	AWG 28-24
0.13-0.33 mm ²	AWG 26-22
0.33-0.52 mm ²	AWG 22-20
0.52-0.82 mm ²	AWG 22-18

Tools

Crimping tool



Contact removal tool



Wire gauge	Designation	Order No.
0.09-0.82mm ²	TL03	198 001 001 0002
Application	Designation	Order No.
for 5A crimp contact	TL08	198 001 000 0006

Notes: The tools for crimp terminal may influence the product quality and stability. Please select the tools recognized by our company.

HMDS-025 High Density module

50V 4A

Inserts



Combination with hinged frame and other modules possible.

Technical characteristics

Specifications	DIN EN 60 664 DIN EN 61 984		
Approvals			
Inserts		Contacts	
Number of contacts	25	Material	copper alloy
Electrical data acc. to EN 61 984		Surface	hard-silver plated
-Rated current	4A		hard-gold plated
-Rated voltage	50V	Contact resistance	≤ 3mΩ
-Rated impulse voltage	0.8kV	Crimp terminal	
-Pollution degree	3	-mm ²	0.09-0.52mm ²
Insulation resistance	≥ 10 ¹⁰ Ω	-AWG	28-20
Material	polycarbonate		
Limiting temperatures	-40°C ...+125°C		
Flammability acc. to UL 94	V0		
Mechanical working life			
- mating cycles	≥ 500		

Current carrying capacity

The current carrying is limited by maximum temperature of materials for inserts and contacts including terminals

Control and test procedures according to DIN EN 60512-5

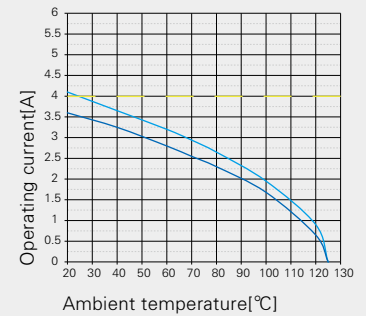

- 24 B hoods/housings with 6 modules, wire gauge: 0.5mm²(turned contacts)
- 24 B hoods/housings with 6 modules, wire gauge: 0.5mm²(stamped contacts)

Crimp terminal

Order crimp contacts separately

Insert	Designation	Order No.
Male	HMDS-025-MC	129 025 010 0001
Female	HMDS-025-FC	129 025 020 0001

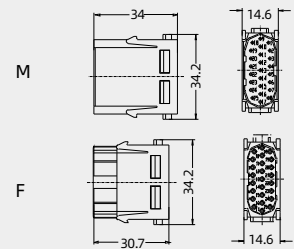

Crimp contacts

Crimp contacts 5A

Contact resistance ≤ 3mΩ
silver plated



gold plated



	Male	Order No.	Female	Order No.
	CSSM-0.25	101 014 110 0101	CSSF-0.25	101 014 120 0101
	CSSM-0.33	101 014 110 0201	CSSF-0.33	101 014 120 0201
	CSSM-0.52	101 014 110 0501	CSSF-0.52	101 014 120 0501
	CSGM-0.25	101 014 210 0101	CSGF-0.25	101 014 220 0101
	CSGM-0.33	101 014 210 0201	CSGF-0.33	101 014 220 0201
	CSGM-0.52	101 014 210 0501	CSGF-0.52	101 014 220 0501

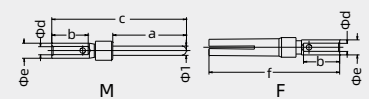

a	b	c	d	e	f
8.10	4.0	14.8	0.64	1.66	14.4
8.10	4.0	14.8	0.90	1.66	14.4
8.10	4.0	14.8	1.12	1.66	14.4

Wire gauge	Stripping length	
0.09-0.25 mm ²	AWG 28-24	5 mm
0.13-0.33 mm ²	AWG 26-22	5 mm
0.33-0.52 mm ²	AWG 22-20	5 mm

Tools

Crimping tool



Contact removal tool



Wire gauge	Designation	Order No.
0.09-0.82mm ²	TL03	198 001 001 0002

Application	Designation	Order No.
for 5A crimp contact	TL08	198 001 000 0006

Notes: The tools for crimp terminal may influence the product quality and stability. Please select the tools recognized by our company.

HMDS-036 High Density module

32V 4A

Inserts



Combination with hinged frame and other modules possible.

Technical characteristics

Specifications	DIN EN 60 664 DIN EN 61 984		
Approvals	UL		
Inserts		Contacts	
Number of contacts	36	Material	copper alloy
Electrical data acc. to EN 61 984		Surface	hard-silver plated
-Rated current	4A		hard-gold plated
-Rated voltage	32V	Contact resistance	≤ 3mΩ
-Rated impulse voltage	0.8kV	Crimp terminal	
-Pollution degree	3	-mm ²	0.09-0.52mm ²
Insulation resistance	≥ 10 ¹⁰ Ω	-AWG	28-22
Material	polycarbonate		
Limiting temperatures	-40°C ...+125°C		
Flammability acc. to UL 94	V0		
Mechanical working life			
- mating cycles	≥ 500		

Crimp terminal

Order crimp contacts separately



Insert	Designation	Order No.
Male	HMDS-036-MC	129 036 010 0001
Female	HMDS-036-FC	129 036 020 0001

Crimp contacts

Crimp contacts 5A

Contact resistance ≤ 3mΩ
silver plated

gold plated



Male	Order No.	Female	Order No.
CSSM-0.25	101 014 110 0101	CSSF-0.25	101 014 120 0101
CSSM-0.33	101 014 110 0201	CSSF-0.33	101 014 120 0201
CSSM-0.52	101 014 110 0501	CSSF-0.52	101 014 120 0501
CSGM-0.25	101 014 210 0101	CSGF-0.25	101 014 220 0101
CSGM-0.33	101 014 210 0201	CSGF-0.33	101 014 220 0201
CSGM-0.52	101 014 210 0501	CSGF-0.52	101 014 220 0501

Tools

Crimping tool



Contact removal tool



Wire gauge	Designation	Order No.
0.09-0.82mm ²	TL03	198 001 001 0002
Application	Designation	Order No.
for 5A crimp contact	TL08	198 001 000 0006

Notes: The tools for crimp terminal may influence the product quality and stability. Please select the tools recognized by our company.

10-47.1 WAIN ELECTRICAL

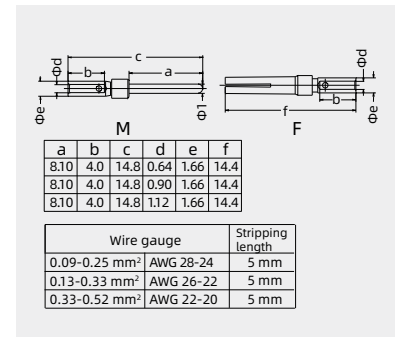
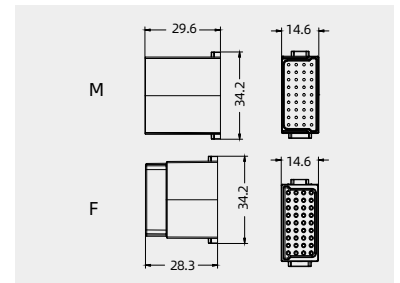
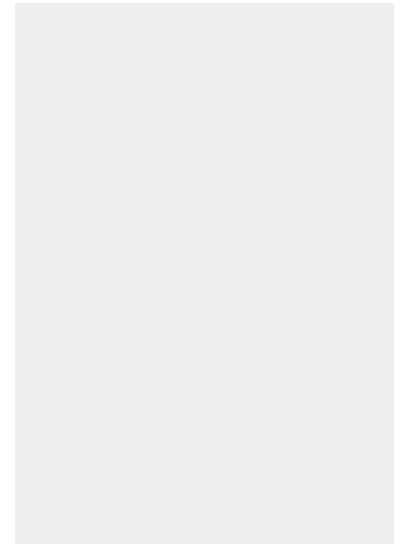

HM-RJ45 module

50V 1A

Inserts



Male inserts only suitable for high structure shells. Combination with hinged frame and other modules possible.

Technical characteristics

Specifications	DIN EN 60 664 DIN EN 61 984
Approvals	ENEC
Inserts	
Number of contacts	8
Electrical data acc. to EN 61 984	
-Rated current	1A
-Rated voltage	50V
-Rated impulse voltage	0.8kV
-Pollution degree	3
Rated voltage acc. to UL	< 30 V
Transmission features	Category 6 /Class E up to 500 MHz; acc. to ISO/IEC 11 801:2002 and EN 50 173-1
Transmission rate	10/100/1000Mbit/10Gbit/s
Insulation resistance	≥ 10 ¹⁰ Ω
Material	polycarbonate
Limiting temperatures	-40°C ...+85°C
Flammability acc. to UL 94	V0
Mechanical working life	
- mating cycle	≥ 500

Inserts for patch cable



Insert	Designation	Order No.
Male	HM-RJ45-M	229 001 001 0001
Female	HM-RJ45-F	129 001 002 0092

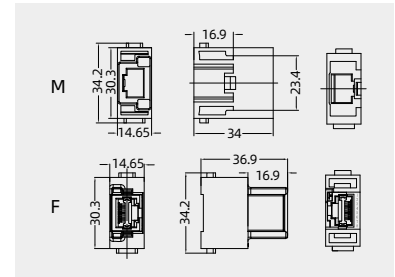

Adapter



Insert	Designation	Order No.
go with male insert for standard cable	HM-RJ45-APT/2	229 001 000 0005

Please refer to page 10-50 for matching cable (no plastic cable)
go with male insert: HM-RJ45-M/APT/2 129 001 001 0002

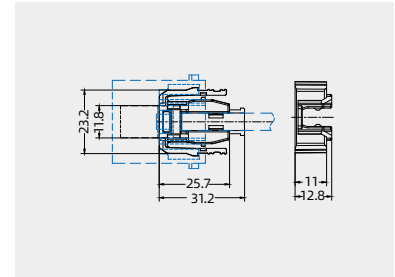

Adapter



Description	Designation	Order No.
go with male insert for standard cable	HM-RJ45-APT	229 001 000 0003

Please refer to page 10-50.1 for matching cable
go with male insert: HM-RJ45-M/APT 129 001 001 0001

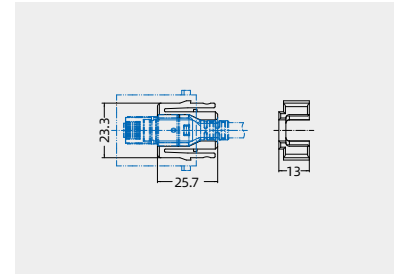

HM-RJ45 module

50V 1A



Inserts

Technical characteristics

Specifications	DIN EN 60 664 DIN EN 61 984
Approvals	
Inserts	
Number of contacts	8
Electrical data acc. to EN 61 984	
-Rated current	1A
-Rated voltage	50V
-Rated impulse voltage	0.8kV
-Pollution degree	3
Rated voltage acc. to UL	< 30 V
Transmission features	Category 6 /Class E up to 500 MHz; acc. to ISO/IEC 11 801:2002 and EN 50 173-1
Transmission rate	10/100/1000Mbit/10Gbit/s
Insulation resistance	$\geq 10^{10} \Omega$
Material	polycarbonate
Limiting temperatures	-40°C ...+85°C
Flammability acc. to UL 94	V0
Mechanical working life	
- mating cycle	≥ 500

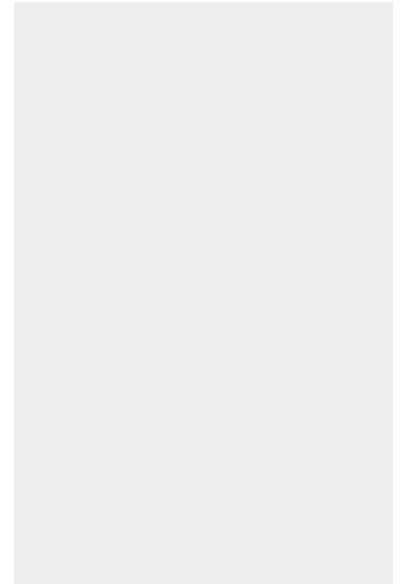

Inserts for patch cable

Insert	Designation	Order No.
	HM-RJ45-M/F	198 002 009 0001



Transmission features: Category 6 /Class E up to 500 MHz

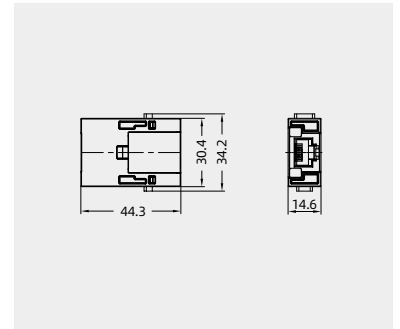

Characteristics

- Preset Registered jack, no need for on-site crimping and assembly
- The male module does not require additional adapter assembly
- Suitable for WAIN standard framework or single module framework
- Transmission features: Category 6 /Class E up to 500 MHz

HM-RJ45 Patch cables

50V 1A

Technical characteristics

Specifications	ISO/IEC 24 702 ISO/IEC 11 801 ISO/IEC 61 935-2
Cat.5 e RJ45 Patch cables	
Transmission features	Category 5 /Class D up to 100 MHz;acc. to ISO/IEC 24 702 or ISO/IEC 11 801
Transmission rate	10/100/1000 Mbit/s
Cable type	1:1 EIA/TIA 568 B, 8 poles
Material cables	SF/UTP, PVC, blue
Limiting temperatures	
- mobile	0°C ...+60°C
- stationary	-40°C ...+80°C
Flammability	flame retardant,halogen-free
Degree of protection	IP20
Cat.6A RJ45 Patch cables	
Transmission features	Category 6 /Class D up to 500 MHz;acc. to ISO/IEC 24 702 or ISO/IEC 11 801
Transmission rate	10/100/1000 Mbit/10Gbit/s
Cable type	EIA/TIA 568 B,8 poles
Material cables	S/FTP,PUR,Water blue
Limiting temperatures	
- mobile	0°C ...+60°C
- stationary	-40°C ...+80°C
Flammability	lame retardant,halogen-free
Degree of protection	IP20

Assembly diagram

HM-RJ45-APT/2



Standard cable¹⁾

1) Further cable length upon request.



Length(L)	Designation	Order No.
1.5m	PC/2-RJ45-1.5(Cat.5e)	906 010 000 0048
2m	PC/2-RJ45-2.0(Cat.5e)	906 010 000 0049
3m	PC/2-RJ45-3.0(Cat.5e)	906 010 000 0050
4m	PC/2-RJ45-4.0(Cat.5e)	906 010 000 0051
5m	PC/2-RJ45-5.0(Cat.5e)	906 010 000 0052
7m	PC/2-RJ45-7.0(Cat.5e)	906 010 000 0053
9m	PC/2-RJ45-9.0(Cat.5e)	906 010 000 0054
10m	PC/2-RJ45-10.0(Cat.5e)	906 010 000 0055

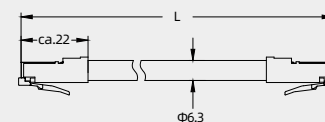

Standard cable¹⁾

1) Further cable length upon request.



Length(L)	Designation	Order No.
1.5m	PC/2-RJ45-1.5(Cat.6A)-PUR	198 002 010 0005
2m	PC/2-RJ45-2.0(Cat.6A)-PUR	198 002 010 0006
3m	PC/2-RJ45-3.0(Cat.6A)-PUR	198 002 010 0007
4m	PC/2-RJ45-4.0(Cat.6A)-PUR	198 002 010 0008

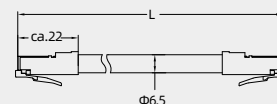

HM-RJ45 Patch cables

50V 1A

Technical characteristics

Specifications	ISO/IEC 24 702 ISO/IEC 11 801 ISO/IEC 61 935-2
Cat.6A RJ45 Patch cables	Assembly diagram HM-RJ45-APT
Transmission features	Category 6 /Class D up to 500 MHz;acc. to ISO/IEC 24 702 or ISO/IEC 11 801
Transmission rate	10/100/1000 Mbit/10Gbit/s
Cable type	EIA/TIA 568 B,8 poles
Material cables	S/FTP,PUR,Water blue
Limiting temperatures	
- mobile	0°C ...+60°C
- stationary	-40°C ...+80°C
Flammability	flame retardant, halogen-free
Degree of protection	IP20



Standard cable¹⁾

1) Further cable length upon request.



Length(L)	Designation	Order No.
0.5m	2RJ45-M08-T-0.5-PUR-Cat.6a	172 008 401 4026
1.0m	2RJ45-M08-T-1.0-PUR-Cat.6a	172 008 401 4020
1.5m	2RJ45-M08-T-1.5-PUR-Cat.6a	172 008 401 4027
2m	2RJ45-M08-T-2.0-PUR-Cat.6a	172 008 401 4019
3m	2RJ45-M08-T-3.0-PUR-Cat.6a	172 008 401 4025
4m	2RJ45-M08-T-4.0-PUR-Cat.6a	172 008 401 4021
7m	2RJ45-M08-T-7.0-PUR-Cat.6a	172 008 401 4018

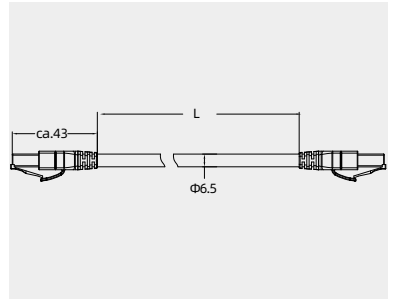

HMP-002 Pneumatic module



Combination with hinged frame and other modules possible.

Inserts

Technical characteristics

Specifications	DIN EN 60 664 DIN EN 61 984		
Approvals			
Inserts		Contacts	
Number of contacts	2	Material	delrin acetal
Colour	blue	Colour	black
Material	polycarbonate	Tube termination	
Limiting temperatures	-40°C ...+80°C	- Internal diameter (ID)	6.0mm / 1/4 "
Flammability acc. to UL 94	V0	Working pressure	up to 8 bar / 116 psi
Mechanical working life		Sealing	
- mating cycles	≥ 500	-Material	FPM
		Shut off valve	
		-Material	polyformaldehyde

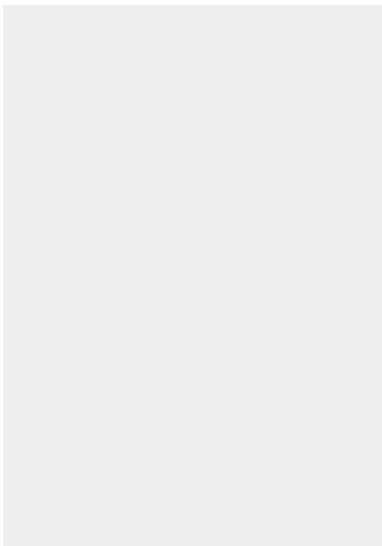

Pneumatic module

Order contacts separately



Description	Designation	Order No.
for 6 mm	HMP-002	129 002 000 0001

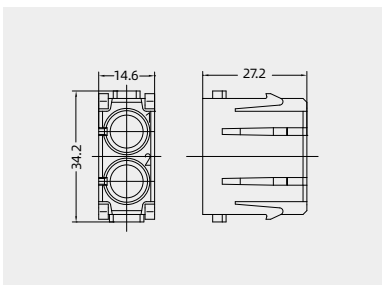

Contacts

Pneumatic contacts for tube internal diameter (ID)



Description	Category	ID	Designation	Order No.
without shut off Male		6.0mm	PCM-6.0	101 100 001 0004
without shut off Female		6.0mm	PCF-6.0	101 100 002 0004

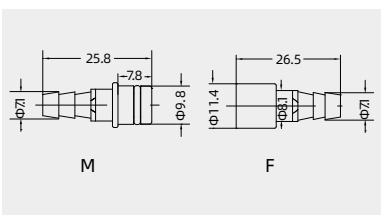

Pneumatic contacts for tube internal diameter (ID)



Description	Category	ID	Designation	Order No.
with shut off Female		6.0mm	PCFS-6.0	101 100 002 0014

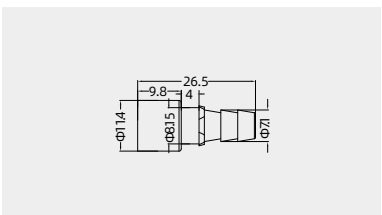

HMP-003 Pneumatic module



Combination with hinged frame and other modules possible.

Inserts

Technical characteristics

Specifications	DIN EN 60 664 DIN EN 61 984		
Approvals			
Inserts		Contacts	
Number of contacts	3	Material	polyformaldehyde
Colour	blue	Colour	black
Material	polycarbonate	Tube termination	
Limiting temperatures	-40°C ...+80°C	- Internal diameter (ID)	1.6mm / 1/16 "
Flammability acc. to UL 94	V0		3.0mm
Mechanical working life			4.0mm / 1/8 "
- mating cycles	≥ 500	Working pressure	up to 8 bar / 116 psi
		Sealing	
		-Material	FPM
		Shut off valve	
		-Material	polyformaldehyde

Pneumatic module
Order contacts separately



Insert	Designation	Order No.
HMP-003		129 003 000 0001

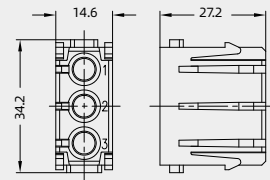

Contacts

Pneumatic contacts
for tubeinternal diameter(ID)



Description	Category	ID	Designation	Order No.
without shut off	Male	1.6 mm	PCM-1.6	101 100 001 0001
		3.0 mm	PCM-3.0	101 100 001 0002
		4.0 mm	PCM-4.0	101 100 001 0003
without shut of	Female	1.6 mm	PCF-1.6	101 100 002 0001
		3.0 mm	PCF-3.0	101 100 002 0002
		4.0 mm	PCF-4.0	101 100 002 0003

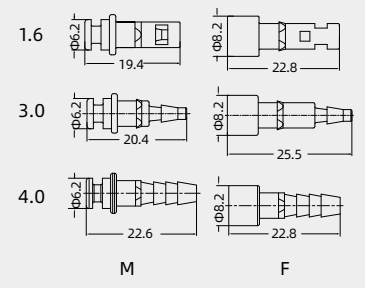

Pneumatic contacts
for tubeinternal diameter(ID)



Description	Category	ID	Designation	Order No.
with shut off	Female	1.6 mm	PCFS-1.6	101 100 002 0011
		3.0 mm	PCFS-3.0	101 100 002 0012
		4.0 mm	PCFS-4.0	101 100 002 0013

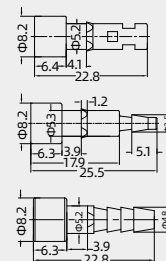

HMP-003 Metal Pneumatic Module



Combination with hinged frame and other modules possible.

Inserts

Technical characteristics

Specifications	DIN EN 60 664 DIN EN 61 984
Approvals	
Inserts	Contacts
Number of contacts	3
Material	polycarbonate
Limiting temperatures	-40°C ... +80°C
Flammability acc. to UL 94	V0
Mechanical working life	
- mating cycles	≥ 500
	Material
	copper
	Colour
	nickel plating
	Tube termination
	- Outer diameter (OD)
	3.0mm / 4.0mm / 6.0mm
	Working pressure
	up to 10 bar / 145 psi
	Sealing
	-Material
	FPM
	Shut off valve
	-Material
	polyformaldehyde

Metal Pneumatic Module
Order contacts separately



Insert	Designation	Order No.
	HMP-003-V2	129 003 000 0505

Contacts

Metal Pneumatic Contacts

Used for Flexible Tube(OD)



Description	Category	OD	Designation	Order No.
without shut off Male		3.0mm	MPCM-OD3.0	101 100 001 0005
		4.0mm	MPCM-OD4.0	101 100 001 0006
		6.0mm	MPCM-OD6.0	101 100 001 0007
without shut off Female		3.0mm	MPCF-OD3.0	101 100 002 0017
		4.0mm	MPCF-OD4.0	101 100 002 0019
		6.0mm	MPCF-OD6.0	101 100 002 0021

Metal Pneumatic Contacts

Used for Flexible Tube(OD)



Description	Category	OD	Designation	Order No.
with shut off Female		3.0mm	MPCFS-OD3.0	101 100 002 0016
		4.0mm	MPCFS-OD4.0	101 100 002 0018
		6.0mm	MPCFS-OD6.0	101 100 002 0020

Tools

Contact removal tool



Application	Designation	Order No.
for HMP-003-V2 Metal Pneumatic Module	TL26	198 001 000 0030

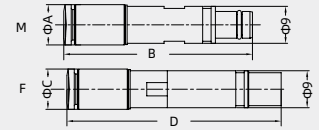
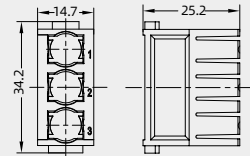

OD	ΦA	B	ΦC	D
3.0	8	43.7	8	48
4.0	9.8	43.9	9.8	50.2
6.0	9.8	45.9	9.8	52.2

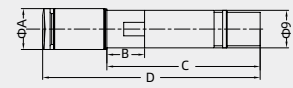

OD	ΦA	B	C	D
3.0	8	71	34.8	48
4.0	9.8	71	36.8	50.2
6.0	9.8	91	36.8	52.2

HMP-003 Metal Pneumatic Module



Combination with hinged frame and other modules possible.

Inserts

Technical characteristics

Specifications	DIN EN 60 664 DIN EN 61 984		
Approvals			
Inserts			
Number of contacts	3	Contacts	
Material	polycarbonate	Material	copper
Limiting temperatures	-40°C ...+80°C	Colour	nickel plating
Flammability acc. to UL 94	V0	Tube termination	
Mechanical working life		- Internal diameter (ID)	3.0mm / 4.0mm / 6.0mm
- mating cycles	≥ 500	Working pressure	up to 10 bar / 145 psi
		Sealing	
		-Material	FPM
		Shut off valve	
		-Material	polyformaldehyde

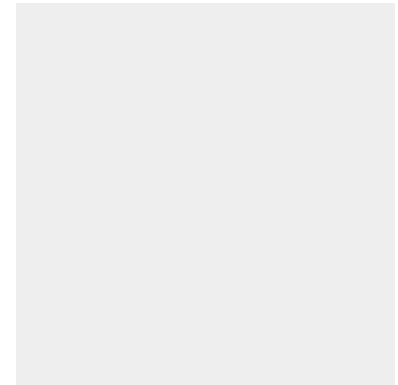

Metal Pneumatic Module
Order contacts separately



Insert	Designation	Order No.
	HMP-003-V2	129 003 000 0505

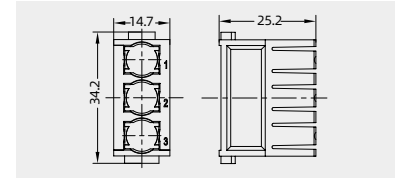

Contacts

Metal Pneumatic Contacts

Used for Flexible Tube(ID)



Description	Category	ID	Designation	Order No.
without shut off	Male	3.0mm	MPCM-ID3.0	101 100 001 1102
		4.0mm	MPCM-ID4.0	101 100 001 1201
		6.0mm	MPCM-ID6.0	101 100 401 1301
without shut off	Female	3.0mm	MPCF-ID3.0	101 100 002 1102
		4.0mm	MPCF-ID4.0	101 100 002 1202
		6.0mm	MPCF-ID6.0	101 100 402 1302

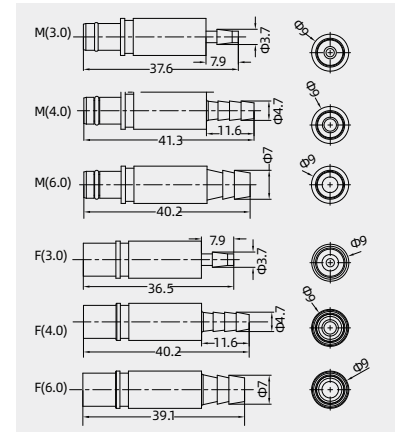

Metal Pneumatic Contacts

Used for Flexible Tube(ID)



Description	Category	ID	Designation	Order No.
with shut off	Male	6.0mm	MPCMS-ID6.0	101 100 400 1301
with shut off	Female	3.0mm	MPCFS-ID3.0	101 100 002 1101
		4.0mm	MPCFS-ID4.0	101 100 002 1201
		6.0mm	MPCFS-ID6.0	101 100 402 1301

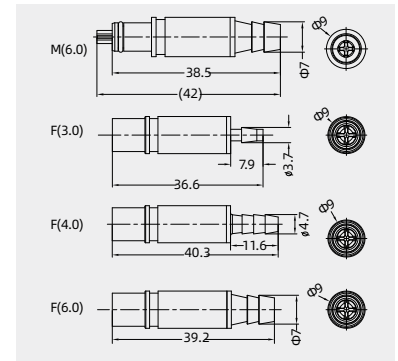

Tools

Contact removal tool



Application	Designation	Order No.
for HMP-003-V2 Metal Pneumatic Module	TL26	198 001 000 0030

HMSC-004 SC Fiber module



Combination with hinged frame and other modules possible.

Inserts

Technical characteristics

Specifications	DIN EN 60 664
	DIN EN 61 984

Approvals

Inserts	
Number of contacts	4
Insertion loss	< 0.5 dB
Material polycarbonate	polycarbonate
Limiting temperatures	-40 ° C ... +85 ° C
Flammability acc. to UL 94	V 0
Mechanical working life	
- mating cycles	≥ 500

Assembly instructions

HMSC-004-MC

Assemble the SC contact
Push the SC contact from the side into the relevant insert (1)
Push the fixing plate from the side over the contacts (2)
B: SC contact fixed in the module

HMSC-004-MC

Assemble the SC contact
Push the centering ferrule (included in delivery) on the SC contact (1)
Push the SC contact from the side into the relevant insert (2)
Push the fixing plate from the side over the contacts (3)
B: SC contact fixed in the module

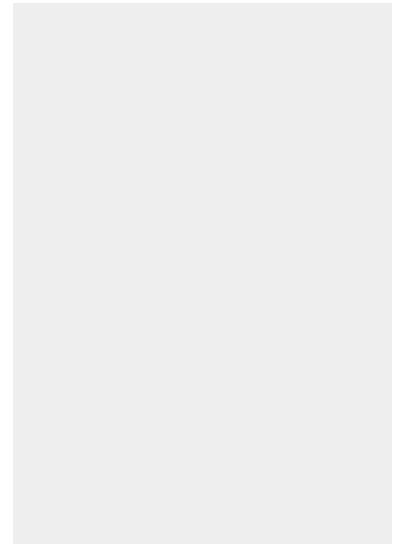

SC module

Order SC Optical fiber connector separately



Insert	Designation	Order No.
Male	HMSC-004-MC	129 004 010 0091
Female	HMSC-004-FC	129 004 020 0091

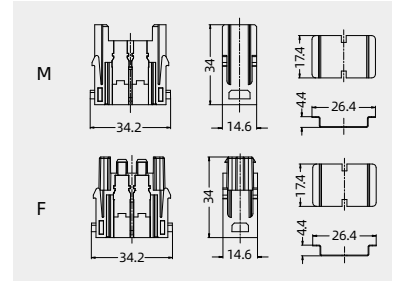

SC Optical fiber connector¹⁾

SC Optical fiber connector
single mode: 9/125µm ,for GI fibre



Describtion	Designation	Order No.
Spare parts ²⁾	SC-PC/SM-3.0	295 000 001 0002
Fiber jumper	PC-SC/UPC-SC/UPC-1.0(9/125µm-φ3.0)	906 010 000 0099
	PC-SC/UPC-SC/UPC-2.0(9/125µm-φ3.0)	906 010 000 0100

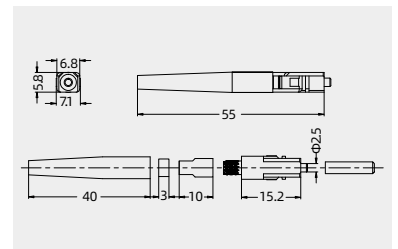

SC Optical fiber connector
multimode: 50/125µm or 62.5/125µm,
for GI fibre



Describtion	Designation	Order No.
Spare parts ²⁾	SC-PC/MM-3.0	295 000 001 0001
Fiber jumper	PC-SC/UPC-SC/UPC-1.0(50/125µm-φ3.0)	906 010 000 0097
	PC-SC/UPC-SC/UPC-2.0(50/125µm-φ3.0)	906 010 000 0098
	PC-SC/UPC-SC/UPC-1.0(62.5/125µm-φ3.0)	906 010 000 0095
	PC-SC/UPC-SC/UPC-2.0(62.5/125µm-φ3.0)	906 010 000 0096

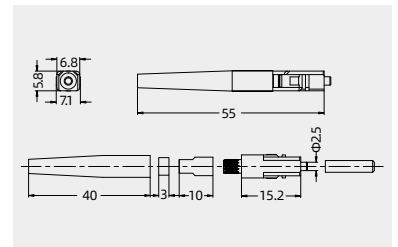

1) SC, FC, ST, LC, MTRJ, different specifications and lengths of fiber optic jumper can be customized
2) Order spare parts should be equipped with corresponding equipment

HASC-004 SC Fiber module

Hoods/Housings: **size 3A with sealing**, please find the details on page 15-54~15-60.
cannot match the metal hood: HP3A/H-BK-SE, HP3A/H-SF-2H-M20,HP3A/H-SF-2H-PG13.5,HP3A/H-SF-2H

Inserts

Technical characteristics

Specifications	DIN EN 60 664 DIN EN 61 984
Approvals	
Inserts	
Number of contacts	4
Insertion loss	< 0,5 dB
Material polycarbonate	polycarbonate
Limiting temperatures	-40 ° C ... +85 ° C
Flammability acc. to UL 94	V 0
Mechanical working life	
- mating cycles	≥ 500
• Degree of protection up to IP 65/IP68	
• For WAIN fibre optic SC Optical fiber connector ;	
up to 4 SC Optical fiber connector	
• For Multimode fibre 50 - 62.5 / 125 µm and	
Singlemode fibre 9 / 125 µm	

Assembly instructions	
HMSC-004-MC	
Assemble the SC contact (1) Push the SC contact from the side into the relevant insert (2) Push the spring clip over the contact body.	
HMSC-004-MC	
Assemble the SC contact (1) Push the centering ferrule (included in delivery) on the SC contact (2) Push the SC contact from the side into the relevant insert (3) Push the spring clip over the contact body.	

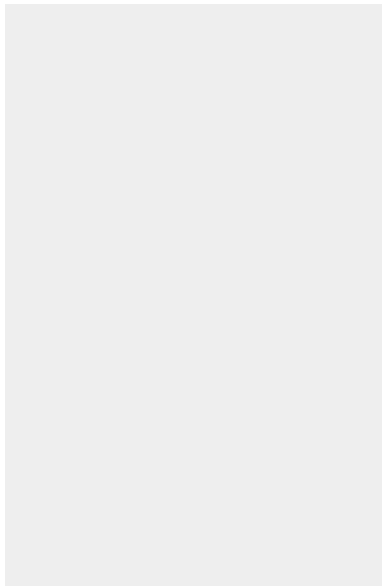

SC module

Order SC Optical fiber connector separately



Insert	Designation	Order No.
Male	HASC-004-MC	121 004 010 0001
Female	HASC-004-FC	121 004 020 0001

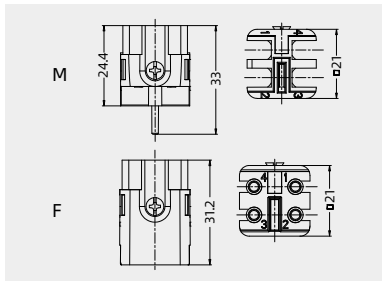

SC Optical fiber connector¹⁾

SC Optical fiber connector
single mode: 9/125µm ,for GI fibre



Describition	Designation	Order No.
Spare parts ²⁾	SC-PC/SM-3.0	295 000 001 0002
Fiber jumper	PC-SC/UPC-SC/UPC-1.0(9/125µm-φ3.0)	906 010 000 0099
	PC-SC/UPC-SC/UPC-2.0(9/125µm-φ3.0)	906 010 000 0100

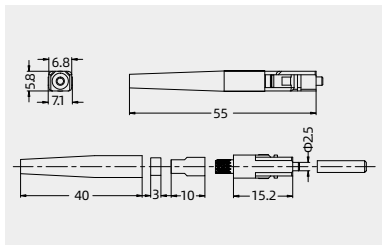

SC Optical fiber connector
multimode: 50/125µm or 62.5/125µm,
for GI fibre



Describition	Designation	Order No.
Spare parts ²⁾	SC-PC/MM-3.0	295 000 001 0001
Fiber jumper	PC-SC/UPC-SC/UPC-1.0(50/125µm-φ3.0)	906 010 000 0097
	PC-SC/UPC-SC/UPC-2.0(50/125µm-φ3.0)	906 010 000 0098
	PC-SC/UPC-SC/UPC-1.0(62.5/125µm-φ3.0)	906 010 000 0095
	PC-SC/UPC-SC/UPC-2.0(62.5/125µm-φ3.0)	906 010 000 0096

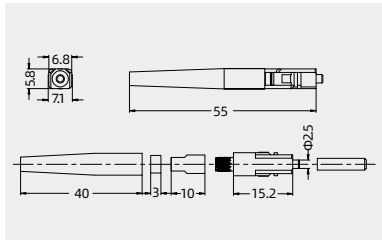

1) SC, FC, ST, LC, MTRJ, different specifications and lengths of fiber optic jumper can be customized
2) Order spare parts should be equipped with corresponding equipment

H3A RJ45

125V AC 1.5A Combination of RJ45 and H3A Hoods/Housings



Inserts

Technical characteristics

Specifications ISO/IEC 11 801:2002
EN 50 173-1

Inserts		Hoods/Housings	
Number of contacts	8	Material	Zinc alloy, SprayingRAL7037
Transmission performance	Category 5 /Class E up to100 MHz acc. to ISO/IEC 11 801:2002, EN 50 173-1	Degree of protection	IP65
Transmission rate	10/100 Mbit/s, 1 Gbit/s		
Shielding	fully shielded, 360° shielding contact		
Cable termination	with piercing		
Limiting temperatures	-40°C ... +70°C		
Mechanical working life			
- mating cycle	≥ 500		

H3A RJ45 With cable gland



Insert	Designation	Order No.
Male	H3A-TE/S-2B-PG11-RJ45/M	110 003 410 1191
	H3A-TE/S-2B-M20-RJ45/M	110 003 400 1192
Female	H3A-BK-1L/W-RJ45/F	110 003 324 1091
	H3A-BK-1L/W-MCV-RJ45/F	110 003 324 1092

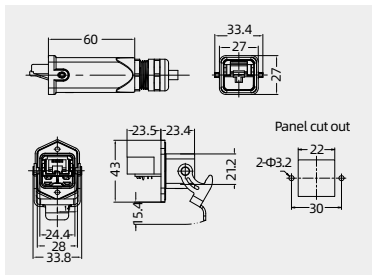

H3A RJ45, side entry, With cable gland



Insert	Designation	Order No.
Male	H3A-SE/S-2B-PG11-RJ45/M	110 003 510 1191
Female	H3A-SE/S-2B-M20-RJ45/M	110 003 510 1192

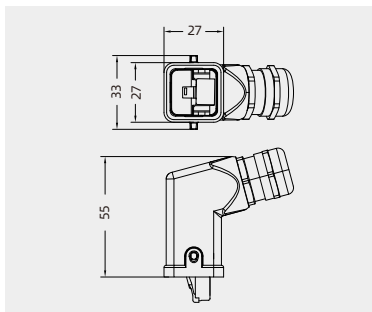

Structural characteristics and assembly instruction

Functional characteristics:

- ① Compatible with standard shielding CAT5 RJ45 connector on the market;
- ② Coding pin provides coding function.

Innovation:

- ① The boss of male adapter 1 positioned together with the groove of network cable of ordinary shielding RJ45;
- ② Male adapter has groove to fix the network cable;
- ③ Male adapter 1 and male adapter 2 cooperate by a hook;
- ④ Coding pin provides coding function.

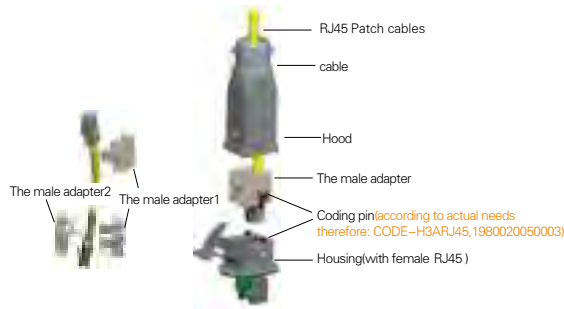

Assembly instructions:

- Step 1: Put one end of the network cable through the cable gland, strip length is about 15 mm, straighten the cable;
- Step 2: Use the wire crimper to connect the cable and the crystal head;
- Step 3: Install the crystal head in the adapter;
- Step 4: Lock the adapter in the hood with a screwdriver (Torque 0.5 N.M), lock the cable gland with a wrench. If needed, a coding pin can also be used, and be careful about the mating of the hood and the housing, and the installation direction of the coding pin;
- Step 5: Lock the hood and the housing with the lever.



H3A RJ45

125V AC 1.5A Combination of RJ45 and H3A Hoods/Housings



Inserts

Technical characteristics

Specifications ISO/IEC 11 801:2002
EN 50 173-1

Inserts		Hoods/Housings	
Number of contacts	8	Material	Zinc alloy, Spraying RAL7037
Transmission performance	Category 6 /Class D up to 500MHZ acc. ISO/IEC 11 801:2002, EN 50 173-1	Degree of protection	IP65
Transmission rate	10/100/1000Mbit/10Gbit/s		
Shielding	fully shielded, 360° shielding contact		
Wire termination	By piercing the contact		
Limiting temperatures	-40°C ... +85°C		
Mechanical working life			
- mating cycle	≥ 500		

H3A RJ45, top entry, With cable gland



Insert	Designation	Order No.
Male	H3A-TE/S-2B-PG11-RJ45/M-cat.6a	121 000 099 0500
	H3A-TE/S-2B-M20-RJ45/M-cat.6a	121 000 099 0501

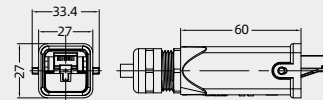

H3A RJ45 With cable gland



Insert	Designation	Order No.
Female	H3A-BK-1L/W-RJ45/F-cat.6a	121 000 099 0502
	H3A-BK-1L/W-MCV-RJ45/F-cat.6a	121 000 099 0503

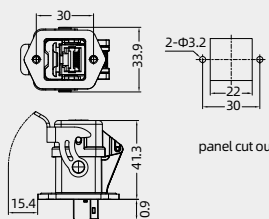
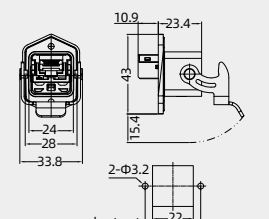

H3A RJ45, side entry, With cable gland



Insert	Designation	Order No.
Male	H3A-SE/S-2B-M20-RJ45/M-cat.6a	110 003 515 1500

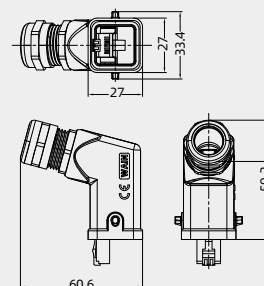

H3A RJ45

48V 16A Combination of RJ45 and H3A Hoods/Housings



Inserts

Technical characteristics

Specifications	ISO/IEC 11 801:2002 EN 50 173-1	
Inserts(male)	Inserts(female)	
Number of contacts	4(data) + 4(power)	Number of contacts 8(data) + 4(power)
Transmission performance	Category 5 /Class E up to 100 MHz acc. to ISO/IEC 11 801:2002, EN 50 173-1	Transmission performance Category 6 /Class D up to 500MHZ acc. ISO/IEC 11 801:2002, EN 50 173-1
Transmission rate	10/100Mbit/s	Transmission rate 10/100/1000Mbit/10Gbit/s
Shielding	fully shielded,360°	Shielding fully shielded,360° shielding contact
Wire termination	Puncture contact(data), IDC puncture(power)	Terminal spring terminal(power)
Cable diameter	6...12mm	Pulse withstand voltage 800V
Rated voltage	48V	Rated voltage 48V
Rated current	16A	Rated current 16A
conductor cross-section	24AWG..22AWG(data), 16AWG(power)	conductor cross-section 22AWG..12AWG(power), 0.34...4.0mm ² (power)
	0.22...0.32mm ² (data), 1.5mm ² (power)	Limiting temperatures -40°C ...+70°C
Limiting temperatures	-40°C ...+70°C	Mechanical working life - mating cycle ≥ 500
Mechanical working life - mating cycle	≥ 500	
Hoods/Housings		
Material	Zinc alloy,SprayingRAL7037	
Degree of protection	IP65	

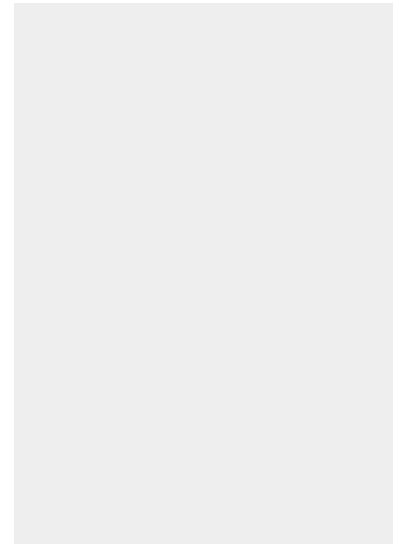

H3A RJ45 With cable gland



Insert	Designation	Order No.
male	H3A-TE/S-2B-M20-004/RJ45-M	121 008 001 0501
female	H3A-BK-1L/W-004/RJ45-F	121 008 002 0501

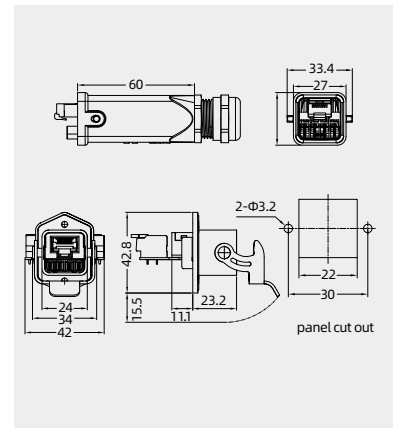

Q-Coax Electromagnetic screening module



Technical characteristics

Specifications	DIN EN 60 664 DIN EN 61 984
Approvals	CE ENEC
Inserts	
Number of contacts	1,2
Insulation resistance	$\geq 10^{10}\Omega$
Material	polycarbonate
Limiting temperatures	-40°C ...+125°C
Flammability acc. to UL 94	V0
Mechanical working life(mating cycles)	≥ 500
Q-Coax contacts	
Number of contacts	
- Q-Coax	4 + shielding
- High Density Q-Coax	8 + shielding
Electrical data acc. to EN 61 984	
- Q-Coax	10A 50V 0.8kV 3
- High Density Q-Coax	5A 50V 0.8kV 3
Rated current	10/5A
Rated voltage	50V
Rated impulse voltage	0.8kV
Pollution degree	3
Material	
- Insulator	polycarbonate
- Outer conductor	zinc alloy
Contact resistance	$\leq 4m\Omega$
Limiting temperatures	-40°C ...+85°C
Flammability acc. to UL 94	V0
Outer surface finish	nickel
Cable diameter	3-9.5mm
D-Sub crimp contacts(5A)	
Material	copper alloy
Surface	hard-gold plated
Contact resistance	$\leq 3m\Omega$
Crimp terminal	
-mm ²	0.09-0.52mm ²
-AWG	28-20
D contacts(10A)	
Material	copper alloy
Surface	hard-gold plated
Contact resistance	$\leq 3m\Omega$
Crimp terminal	
-mm ²	0.14-2.5mm ²
-AWG	26-14

• Features

- Shielding bus separate from housing potential
- Perfect for transmission of sensitive signals
- The four pole Q-Coax contact is suitable for Ethernet Cat. 5e and PROFIBUS when diagonally wiring of the data pairs.

Q-Coax Electromagnetic screening module

Assembly instructions see P10-63.



Combination with hinged frame and other modules possible.

Crimp terminal



Insert	Designation	Order No.
Male	H2M-002-M	129 002 001 0001
Female	H2M-002-F	129 002 002 0001

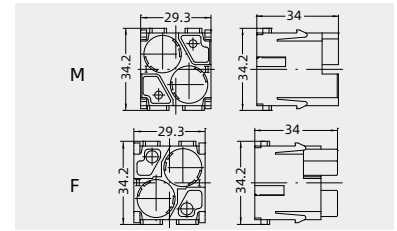

Q-Coax metal adapter



Description	Designation	Order No.
	APT-H2MQ	198 002 007 0006

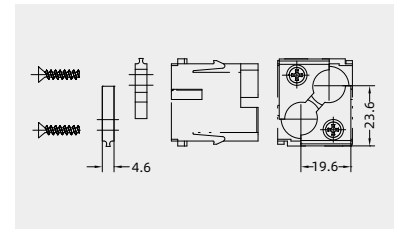

Q-Coax plastic adapter



Description	Designation	Order No.
	APT.P-H2MQ	198 002 007 0032

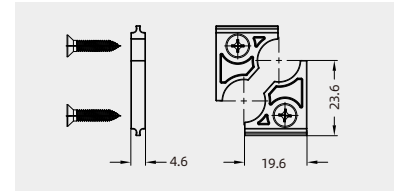

Rubber stopper



Description	Designation	Order No.
	φ16*10	198 002 099 0035

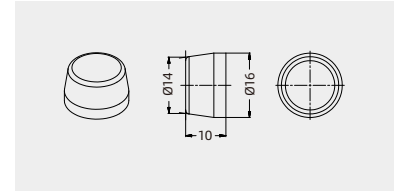

Q-Coax 4 + shielding

Crimp contacts 10A
Order crimp contacts separately
Cable diameter 3mm-9.5mm



Description	Designation	Order No.
Male	EMC-004-MC	129 004 010 0082
Female	EMC-004-FC	129 004 020 0082

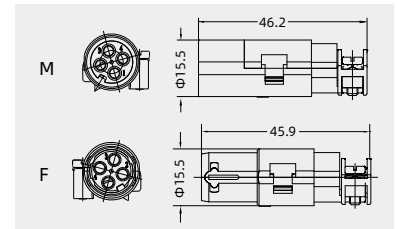

HM

Crimp contacts

Crimp contacts 10A

Contact resistance ≤ 3mΩ
gold plated



More10A crimp contacts
see P13-02,P13-03.

Wire gauge	Male	Order No.	Female	Order No.
0.09-0.25	CDGM-0.25	101 017 210 0101	CDGF-0.25	101 017 220 0101
0.14-0.37	CDGM-0.37	101 017 210 0301	CDGF-0.37	101 017 220 0301
0.5	CDGM-0.50	101 017 210 0401	CDGF-0.50	101 017 220 0401
0.75	CDGM-0.75	101 017 210 0601	CDGF-0.75	101 017 220 0601
1	CDGM-1.0	101 017 210 0801	CDGF-1.0	101 017 220 0801
1.5	CDGM-1.5	101 017 210 0901	CDGF-1.5	101 017 220 0901
2.5	CDGM-2.5	101 017 210 1001	CDGF-2.5	101 017 220 1001

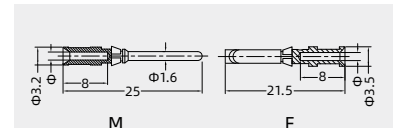

Detail please find the crimp contacts series
When the wire gauge is less than 0.75mm², it's better to use the auxiliary pin assembly tool TL15.

Notes: The tools for crimp terminal may influence the product quality and stability. Please select the tools recognized by our company.

*Please find the details of crimp contact tools on page 32-02~32-05.

Q-Coax Electromagnetic screening module

Assembly instructions see P10-63.



Combination with hinged frame and other modules possible.

Crimp terminal



Insert	Designation	Order No.
Male	H2M-002-M	129 002 001 0001
Female	H2M-002-F	129 002 002 0001

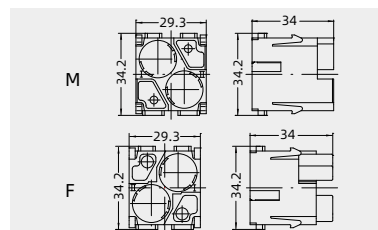

Q-Coax metal adapter



Description	Designation	Order No.
	APT-H2MQ	198 002 007 0006

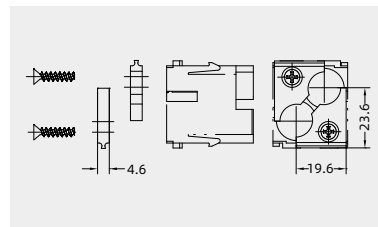

Q-Coax plastic adapter

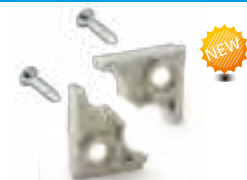

Description	Designation	Order No.
	APT.P-H2MQ	198 002 007 0032

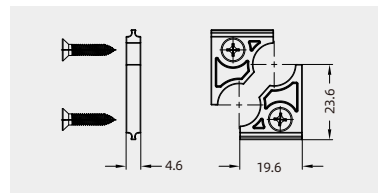

Rubber stopper



Description	Designation	Order No.
	φ16*10	198 002 099 0035

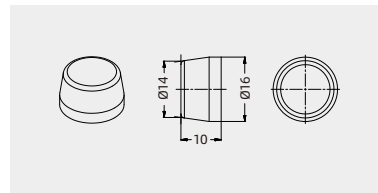

Q-Coax 8 + shielding

Crimp contacts 5A
Order crimp contacts separately
Cable diameter 3mm-9.5mm



Description	Designation	Order No.
Male	EMC-008-MC	129 008 010 0082
Female	EMC-008-FC	129 008 020 0082

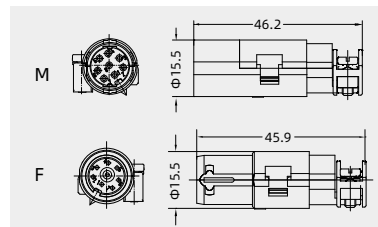

Crimp contacts

Crimp contacts 5A

Contact resistance ≤ 3mΩ
gold plated



Male	Order No.	Female	Order No.
CSGM-0.25	101 014 210 0101	CSGF-0.25	101 014 220 0101
CSGM-0.33	101 014 210 0201	CSGF-0.33	101 014 220 0201
CSGM-0.52	101 014 210 0501	CSGF-0.52	101 014 220 0501

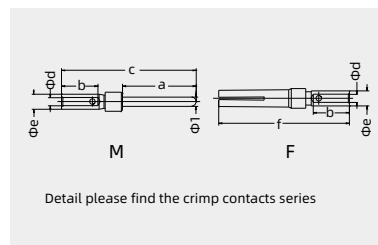

Notes: The tools for crimp terminal may influence the product quality and stability. Please select the tools recognized by our company.

*Please find the details of crimp contact tools on page 32-02~32-05.

Q-Coax Electromagnetic screening module

Assembly instructions see P10-63.

Hoods/Housings: size 3A with sealing, please find the details on page 10-64~10-70.

Crimp terminal



Insert	Designation	Order No.
Male	H3A-001-M	121 001 001 0001
Female	H3A-001-F	121 001 002 0001

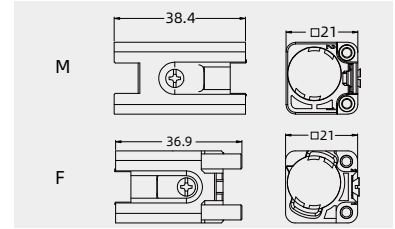

Q-Coax 4 + shielding

Crimp contacts 10A
Order crimp contacts separately
Cable diameter 3mm-9.5mm



Description	Designation	Order No.
Male	EMC-004-MC	129 004 010 0082
Female	EMC-004-FC	129 004 020 0082

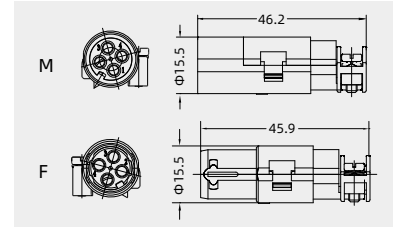

Q-Coax 8 + shielding

Crimp contacts 5A
Order crimp contacts separately
Cable diameter 3mm-9.5mm



Description	Designation	Order No.
Male	EMC-008-MC	129 008 010 0082
Female	EMC-008-FC	129 008 020 0082

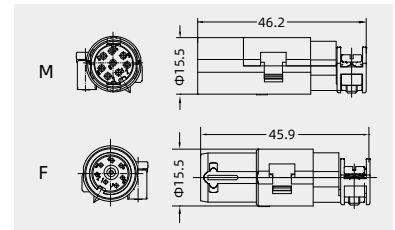

Crimp contacts

Crimp contacts 5A

Contact resistance $\leq 3m\Omega$
gold plated



Male	Order No.	Female	Order No.
CSGM-0.25	101 014 210 0101	CSGF-0.25	101 014 220 0101
CSGM-0.33	101 014 210 0201	CSGF-0.33	101 014 220 0201
CSGM-0.52	101 014 210 0501	CSGF-0.52	101 014 220 0501

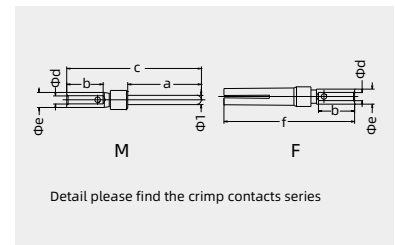

Crimp contacts 10A

Contact resistance $\leq 3m\Omega$
gold plated



Wire gauge	Male	Order No.	Female	Order No.
0.09-0.25	CDGM-0.25	101 017 210 0101	CDGF-0.25	101 017 220 0101
0.14-0.37	CDGM-0.37	101 017 210 0301	CDGF-0.37	101 017 220 0301
0.5	CDGM-0.50	101 017 210 0401	CDGF-0.50	101 017 220 0401
0.75	CDGM-0.75	101 017 210 0601	CDGF-0.75	101 017 220 0601
1	CDGM-1.0	101 017 210 0801	CDGF-1.0	101 017 220 0801
1.5	CDGM-1.5	101 017 210 0901	CDGF-1.5	101 017 220 0901
2.5	CDGM-2.5	101 017 210 1001	CDGF-2.5	101 017 220 1001

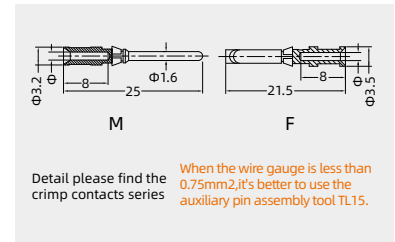

Notes: The tools for crimp terminal may influence the product quality and stability. Please select the tools recognized by our company.

*Please find the details of crimp contact tools on page 32-02~32-05.

Coax Electromagnetic screening module



Technical characteristics

Specifications	DIN EN 60 664	DIN EN 61 984
Approvals	CE ENEC	
Inserts		
Number of contacts	1,2	
Insulation resistance	$\geq 10^{10}\Omega$	
Material	polycarbonate	
Limiting temperatures	-40°C ...+85°C	
Flammability acc. to UL 94	V0	
Mechanical working life(mating cycles)	≥ 500	
Coax contacts		
Number of contacts	1 + shielding	
Electrical data acc. to EN 61 984		
- D Coax	10A 50V 0.8kV 3	
- E Coax	16A 50V 0.8kV 3	
Rated current	10/16A	
Rated voltage	50V	
Rated impulse voltage	0.8kV	
Pollution degree	3	
Impedance		
- D Coax	75Ω	
- E Coax	50Ω	
Material		
- Insulator	polycarbonate	
- Outer conductor	zinc alloy	
Contact resistance	$\leq 4m\Omega$	
Limiting temperatures	-40°C ...+85°C	
Flammability acc. to UL 94	V0	
Outer surface finish	nickel	
Cable diameter	3-9.5mm	
D Coax contacts(10A)		
Material	copper alloy	
Surface	hard-gold plated	
Contact resistance	$\leq 3m\Omega$	
Crimp terminal		
-mm ²	0.14-2.5mm ²	
-AWG	26-14	
E Coax contacts		
Material	copper alloy	
Surface	hard-gold plated	
Contact resistance	$\leq 1m\Omega$	
Crimp terminal		
-mm ²	0.14-4mm ²	
-AWG	26-12	

Features

- Shielding bus separate from housing potential
- Perfect for transmission of sensitive signals
- The four pole Q-Coax contact is suitable for Ethernet Cat. 5e and PROFIBUS when diagonally wiring of the data pairs.

Transmission characteristics

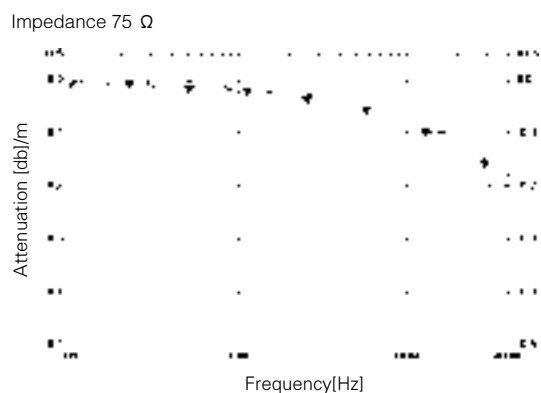

- 75 Ω cable
- 75 Ω cable with D Coax contacts
- 75 Ω coax cable diameter shielding: 7.3 mm

Impedance 50 Ω

E Coax with ETCS S21 Eurobalise cable (4 mm ²)	27 MHz
Return loss [db]	35,4
Attenuation [db]	0,017

E Coax with RG 213 cable(2.5 mm ²)	200 MHz	500 MHz	1,0 GHz	1,2 GHz	1,5 GHz	2,0 GHz	2,5 GHz
Return loss [db]	23,8	21,1	>18,7	>17,7	>16,4	>14,1	>12,0
Attenuation [db]	0,07	0,11	0,17	0,2	<0,23	<0,53	<2,0

Coax Electromagnetic screening module

Assembly instructions see P10-63.



Combination with hinged frame and other modules possible.

Crimp terminal



Insert	Designation	Order No.
Male	H2M-002-M	129 002 001 0001
Female	H2M-002-F	129 002 002 0001

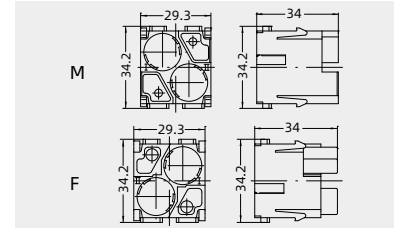

Q-Coax metal adapter



Description	Designation	Order No.
	APT-H2MQ	198 002 007 0006

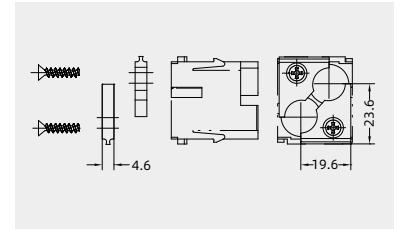

Q-Coax plastic adapter



Description	Designation	Order No.
	APT.P-H2MQ	198 002 007 0032

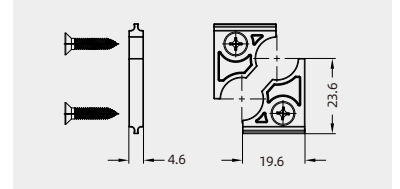

Rubber stopper



Description	Designation	Order No.
	φ16*10	198 002 099 0035

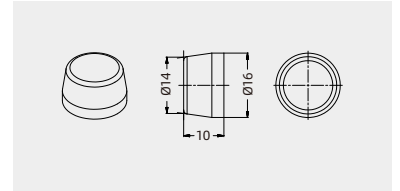

D Coax 1 + shielding

Impedance 75Ω
Crimp contacts 10A
Order crimp contacts separately
Cable diameter 3mm-9.5mm



Description	Designation	Order No.
Male	EMC-001-MC	129 001 010 0082
Female	EMC-001-FC	129 001 020 0082

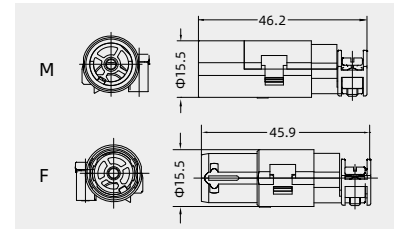

Crimp contacts

Crimp contacts 10A

Contact resistance ≤ 3mΩ
gold plated



Wire gauge	Male	Order No.	Female	Order No.
0.09-0.25	CDGM-0.25	101 017 210 0101	CDGF-0.25	101 017 220 0101
0.14-0.37	CDGM-0.37	101 017 210 0301	CDGF-0.37	101 017 220 0301
0.5	CDGM-0.50	101 017 210 0401	CDGF-0.50	101 017 220 0401
0.75	CDGM-0.75	101 017 210 0601	CDGF-0.75	101 017 220 0601
1	CDGM-1.0	101 017 210 0801	CDGF-1.0	101 017 220 0801
1.5	CDGM-1.5	101 017 210 0901	CDGF-1.5	101 017 220 0901
2.5	CDGM-2.5	101 017 210 1001	CDGF-2.5	101 017 220 1001

More 10A crimp contacts
see P13-02, P13-03.

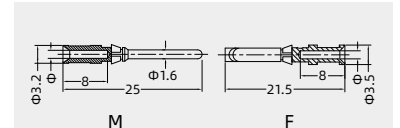

Detail please find the crimp contacts series
When the wire gauge is less than 0.75mm², it's better to use the auxiliary pin assembly tool TL15.

Notes: The tools for crimp terminal may influence the product quality and stability. Please select the tools recognized by our company.

*Please find the details of crimp contact tools on page 32-02~32-05.

Coax Electromagnetic screening module

Assembly instructions see P10-63.



Combination with hinged frame and other modules possible.

Crimp terminal



Insert	Designation	Order No.
Male	H2M-002-M	129 002 001 0001
Female	H2M-002-F	129 002 002 0001

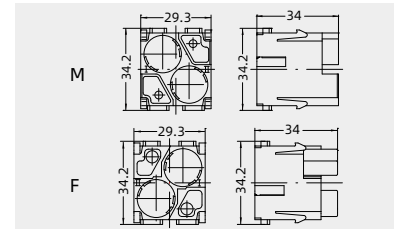

Q-Coax metal adapter



Description	Designation	Order No.
	APT-H2MQ	198 002 007 0006

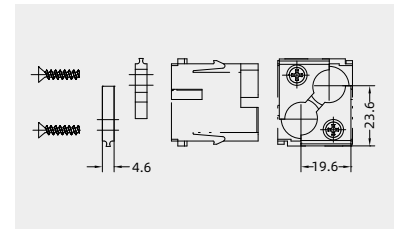

Q-Coax plastic adapter



Description	Designation	Order No.
	APT.P-H2MQ	198 002 007 0032

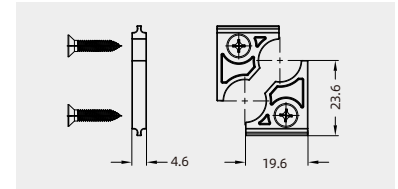

Rubber stopper



Description	Designation	Order No.
	φ16*10	198 002 099 0035

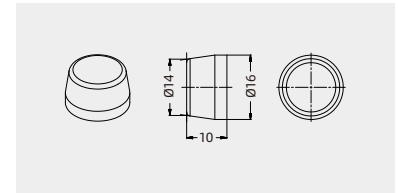

E Coax 1 + shielding

Impedance 50Ω
Crimp contacts 16A
Order crimp contacts separately
Cable diameter 3mm-9.5mm



Description	Designation	Order No.
Male	EMC-001-MC/E	129 001 010 0083
Female	EMC-001-FC/E	129 001 020 0083

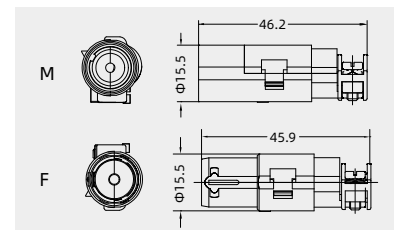

Crimp contacts

Crimp contacts 16A

Contact resistance ≤ 1mΩ
gold plated



Wire gauge	Male	Order No.	Female	Order No.
0.14-0.37	CEGM-0.37	101 019 210 0301	CEGF-0.37	101 019 220 0301
0.5	CEGM-0.50	101 019 210 0401	CEGF-0.50	101 019 220 0401
0.75	CEGM-0.75	101 019 210 0601	CEGF-0.75	101 019 220 0601
1	CEGM-1.0	101 019 210 0801	CEGF-1.0	101 019 220 0801
1.5	CEGM-1.5	101 019 210 0901	CEGF-1.5	101 019 220 0901
2.5	CEGM-2.5	101 019 210 1001	CEGF-2.5	101 019 220 1001
3	CEGM-3.0	101 019 210 1101	CEGF-3.0	101 019 220 1101
4	CEGM-4.0	101 019 210 1201	CEGF-4.0	101 019 220 1201

More 16A crimp contacts see P13-04.

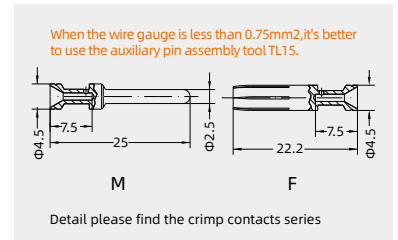

Notes: The tools for crimp terminal may influence the product quality and stability. Please select the tools recognized by our company.

*Please find the details of crimp contact tools on page 32-02~32-05.

Coax Electromagnetic screening module

Assembly instructions see P10-63.

Hoods/Housings: size 3A(top entry) with sealing, please find the details on page 10-64~10-70.

Crimp terminal



Insert	Designation	Order No.
Male	H3A-001-M	121 001 001 0001
Female	H3A-001-F	121 001 002 0001

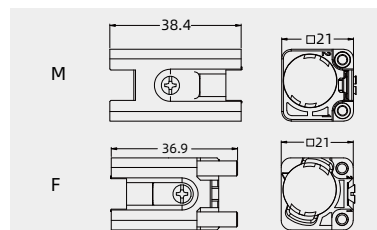

D Coax 1 + shielding

Impedance 75Ω
Crimp contacts 10A
Order crimp contacts separately
Cable diameter 3mm-9.5mm



Description	Designation	Order No.
Male	EMC-001-MC	129 001 010 0082
Female	EMC-001-FC	129 001 020 0082

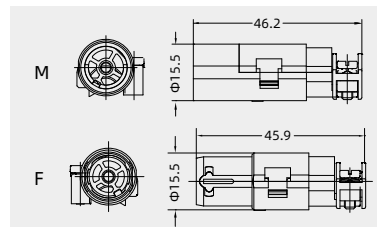

E Coax 1 + shielding

Impedance 50Ω
Crimp contacts 16A
Order crimp contacts separately
Cable diameter 3mm-9.5mm



Description	Designation	Order No.
Male	EMC-001-MC/E	129 001 010 0083
Female	EMC-001-FC/E	129 001 020 0083

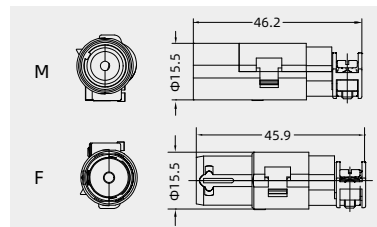

Crimp contacts

Crimp contacts 10A

Contact resistance ≤ 3mΩ
gold plated



More 10A crimp contacts
see P13-02, P13-03.

Wire gauge	Male	Order No.	Female	Order No.
0.09-0.25	CDGM-0.25	101 017 210 0101	CDGF-0.25	101 017 220 0101
0.14-0.37	CDGM-0.37	101 017 210 0301	CDGF-0.37	101 017 220 0301
0.5	CDGM-0.50	101 017 210 0401	CDGF-0.50	101 017 220 0401
0.75	CDGM-0.75	101 017 210 0601	CDGF-0.75	101 017 220 0601
1	CDGM-1.0	101 017 210 0801	CDGF-1.0	101 017 220 0801
1.5	CDGM-1.5	101 017 210 0901	CDGF-1.5	101 017 220 0901
2.5	CDGM-2.5	101 017 210 1001	CDGF-2.5	101 017 220 1001

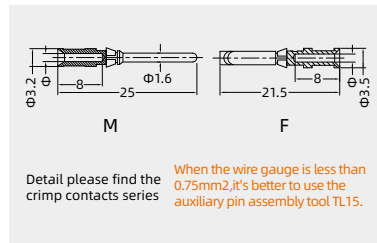

Crimp contacts 16A

Contact resistance ≤ 1mΩ
gold plated



More 16A crimp contacts see P13-04.

Wire gauge	Male	Order No.	Female	Order No.
0.14-0.37	CEGM-0.37	101 019 210 0301	CEGF-0.37	101 019 220 0301
0.5	CEGM-0.50	101 019 210 0401	CEGF-0.50	101 019 220 0401
0.75	CEGM-0.75	101 019 210 0601	CEGF-0.75	101 019 220 0601
1	CEGM-1.0	101 019 210 0801	CEGF-1.0	101 019 220 0801
1.5	CEGM-1.5	101 019 210 0901	CEGF-1.5	101 019 220 0901
2.5	CEGM-2.5	101 019 210 1001	CEGF-2.5	101 019 220 1001
3	CEGM-3.0	101 019 210 1101	CEGF-3.0	101 019 220 1101
4	CEGM-4.0	101 019 210 1201	CEGF-4.0	101 019 220 1201

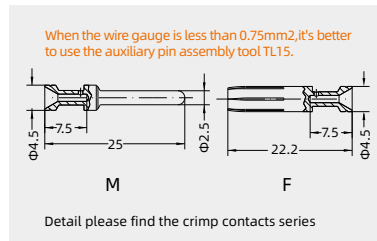

Notes: The tools for crimp terminal may influence the product quality and stability. Please select the tools recognized by our company.

*Please find the details of crimp contact tools on page 32-02~32-05.

Assembly instructions

Q-Coax inserts

1. Strip cable acc. to drawing 1 and fold the shielding over the cable.
2. Crimp Dcontacts onto the wires.
3. Insert D contacts into corresponding cavities of insulator until they are snapped in.
4. Fit the insert including the cable into the opened shielded bushing. The coding pin of the shielded bushing has to meet the groove of the insulator.
5. Clamp the tilt over the shielding onto the cable by means of the special clamp (small opening for cable diameter of 3 - 6 mm, large opening for cable diameter of 6 - 9.5 mm).
6. Check the wiring.
7. Close the shielded bushing with the cover and insert it into the corresponding cavity of the Quintax Module as usual.

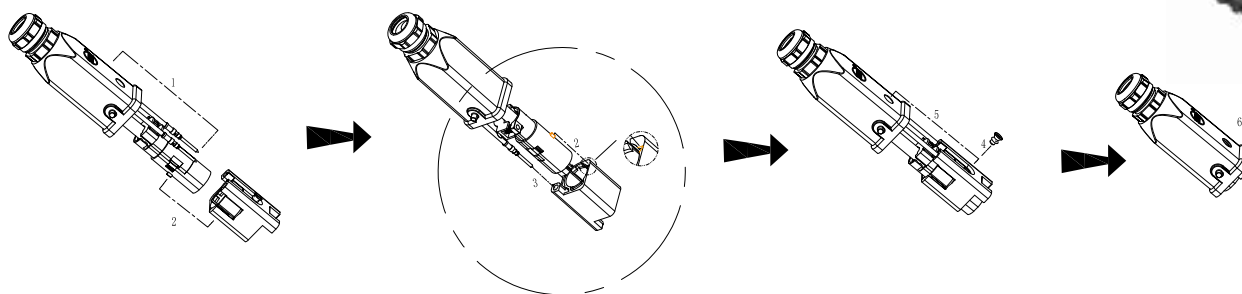
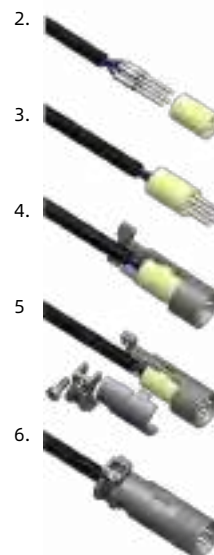
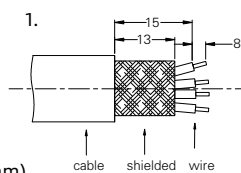

Installation instruction of H3A-001-M/F

Step 1: cable conductor will pass through H3A housing and Coax mortise (assembly type shown in the above figure) and 2pin D-type cold pressing pin will be installed. Refer to figure 1.

Step 2: "triangulation positioning key" on the housing of Coax mortise is directed at "triangulation positioning slot" on the H3A-001-M/F plug for installation, which is shown in the figure 2. In addition, assembly is completed if "click" is heard. Namely, step surface of Coax has been stuck by the card hook.

Step 3: 2 pin D-type pin will be installed in H3A-001-M/F mortise as per sequence of hole site.

Step 4: grounding screw of H3A-001-M/F will be removed.

Step 5: In addition, H3A-001-M/F mortise will be installed in H3A housing, aiming at grounding hole.

Step 6: At last, grounding screw will be locked and installation is completed.

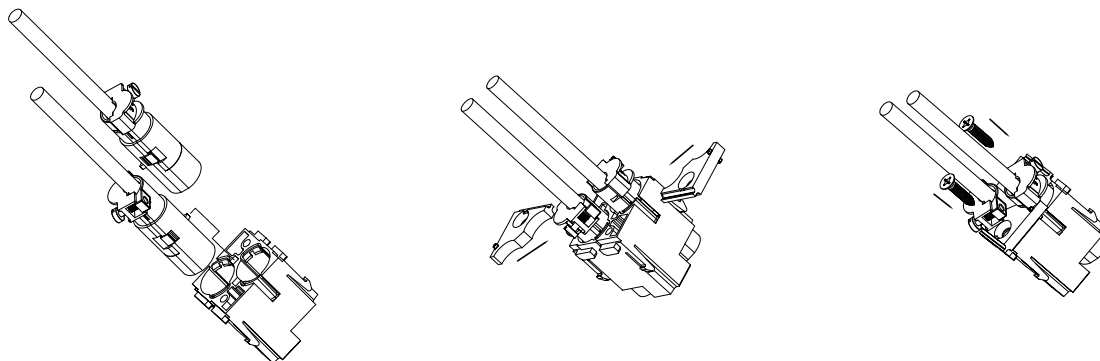

Installation instruction of H2M-002-M/F

Step 1: slug of Coax that has been installed will be installed in the plug of H2M-002-M/F. "triangulation positioning key" on the housing of Coax mortise must be directed at the "positioning slot" on the plug of H2M-002-M/F in the installation process. In addition, assembly is completed if "click" is heard. Namely, step surface of Coax has been stuck by the card hook.

Step 2: a pair of APT-H2MQ adapter will be horizontally installed at the fixed step surface of H2M-002-M/F and Coax slug as per the arrow direction. Refer to the figure 2.

Step 3: the adapter will be fixed with the screw lock, which means that H2M-002-M/F module has been installed.

H2MC-012 Coaxial module

50V 1.5A

Inserts



Combination with hinged frame and other modules possible.

Technical characteristics

Specifications	DIN EN 60 664 DIN EN 61 984
Approvals	
Inserts	
Number of contacts	12
Electrical data acc. to EN 61 984	
-Rated current	1.5A
-Rated voltage	50V
-Contact resistance	≤ 10mΩ
-Impedance	50Ω, 75Ω
-Pollution degree	3
Insulation resistance	≥ 10 ¹⁰ Ω
Material	polycarbonate
Limiting temperatures	-40°C ... +125°C
Flammability acc. to UL 94	V0
Mechanical working life	≥ 500
- mating cycle	≥ 500

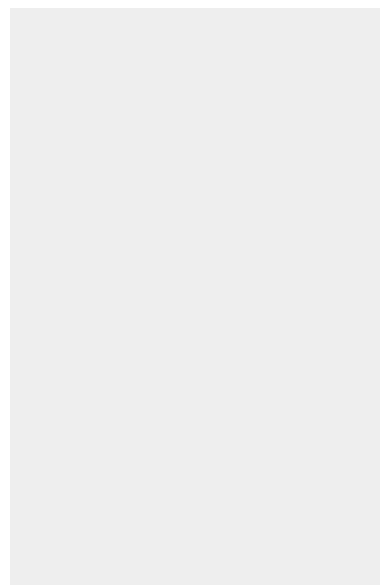

Coaxial Module

Order Coaxial contacts separately



Insert	Designation	Order No.
Male	H2MC-012-MC	129 012 010 0503
Female	H2MC-012-FC	129 012 020 0503

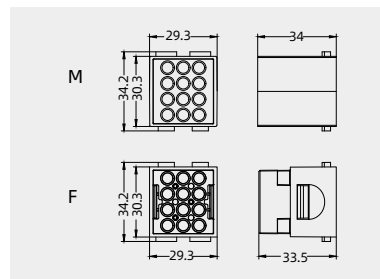

Coaxial contacts

Contact resistance ≤ 10mΩ
Impedance 50Ω
Gold plated



Male	Order No.	Female	Order No.
SCGM50-5.5	101 110 210 0002	SCGF50-5.5	101 110 220 0002

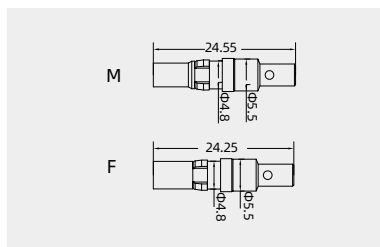

3A Plastic hoods/housings

With sealing

Degree of protection: IP65

Hoods, top entry



Thread	Designation	Order No.
M20	H3A.P-TE/S-2B-M20	118 003 410 1102
PG11	H3A.P-TE/S-2B-PG11	118 003 410 1108

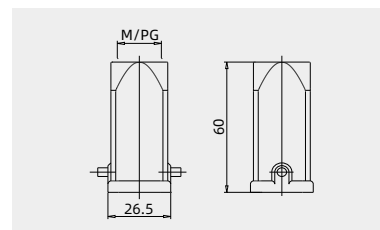

Bulkhead mounted housings



Thread	Designation	Order No.
---	H3A.P-BK-1L	118 003 327 1001

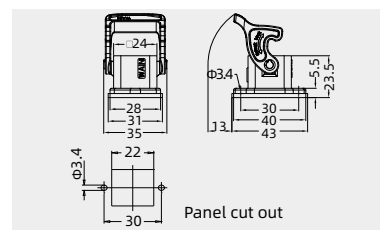

Surface mounted housings



Thread	Designation	Order No.
M20	H3A.P-SF-1L-M20	118 003 227 1002
PG11	H3A.P-SF-1L-PG11	118 003 227 1008

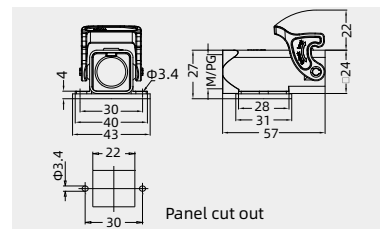

Housings, cable to cable



Thread	Designation	Order No.
M20	H3A.P-CCT-1L-M20	118 003 727 1002
PG11	H3A.P-CCT-1L-PG11	118 003 727 1008

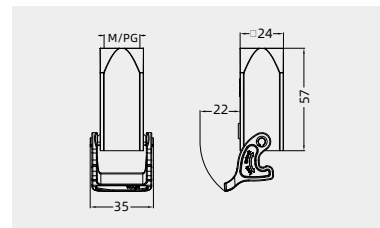



3A Plastic hoods/housings

With sealing

Degree of protection: IP65

Protection covers



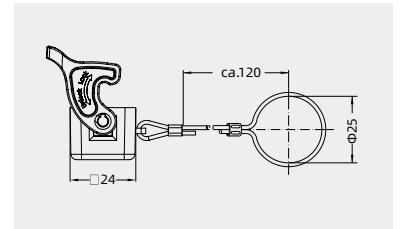

Connect way	Designation	Order No.
	H3A-CV-1L/1M (for male insert)	110 003 027 8001
	H3A-CV-1L/1F(for female insert)	110 003 027 8002



Protection covers



Connect way	Designation	Order No.
	H3A-CV/S-2B/1	110 003 010 8003
	H3A-CV/S-2B/2	110 003 010 8006

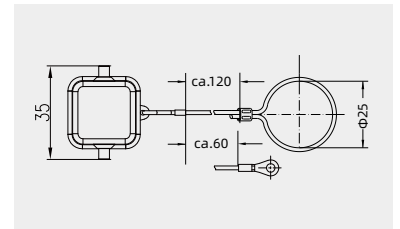

3A Metal hoods/housings

With sealing

Degree of protection: IP65

Hoods, top entry



Thread	Designation	Order No.
M20	H3A-TE/S-2B-M20	110 003 410 1102
PG11	H3A-TE/S-2B-PG11	110 003 410 1108

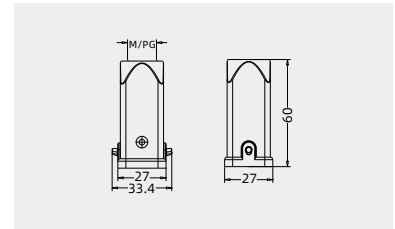

Bulkhead mounted housings



Thread	Designation	Order No.
---	H3A-BK-1L/W	110 003 324 1001

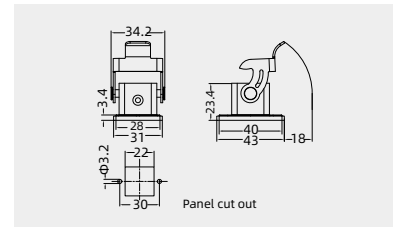

Bulkhead mounted housings



Thread	Designation	Order No.
---	H3A-BK-1L/W-MCV/S	110 003 364 1103

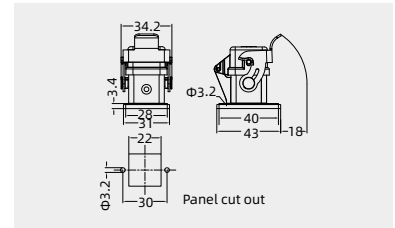

Surface mounted housings



Thread	Designation	Order No.
M20	H3A-SF-1L/W-M20	110 003 224 1002
PG11	H3A-SF-1L/W-PG11	110 003 224 1008

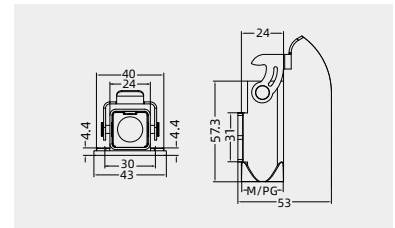

Housings, cable to cable



Thread	Designation	Order No.
M20	H3A-CCT-1L/W-M20	110 003 724 1002
PG11	H3A-CCT-1L/W-PG11	110 003 724 1008

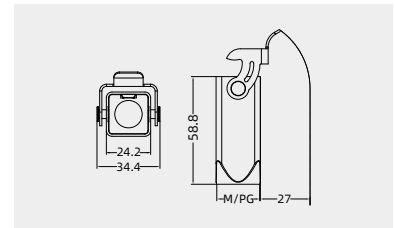

3A Metal hoods/housings(EMC)

With sealing

Degree of protection: IP65

Hoods, top entry



Thread	Designation	Order No.
M20	EMC.H3A-TE/S-2B-M20	110 603 410 1102
PG11	EMC.H3A-TE/S-2B-PG11	110 603 410 1108

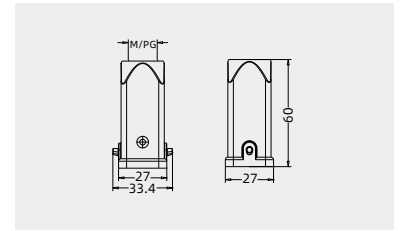

Bulkhead mounted housings



Thread	Designation	Order No.
---	EMCD.H3A-BK-1L/W	110 603 324 1101

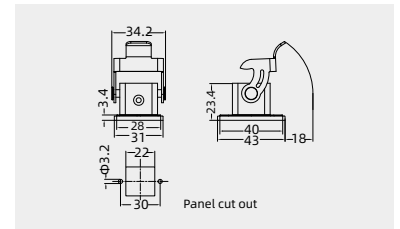

Bulkhead mounted housings



Thread	Designation	Order No.
---	EMCD.H3A-BK-1L/W-MCV/S	110 603 364 1103

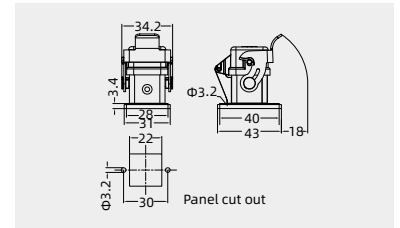

Surface mounted housings



Thread	Designation	Order No.
M20	EMC.H3A-SF-1L/W-M20	110 603 224 1002
PG11	EMC.H3A-SF-1L/W-PG11	110 603 224 1008

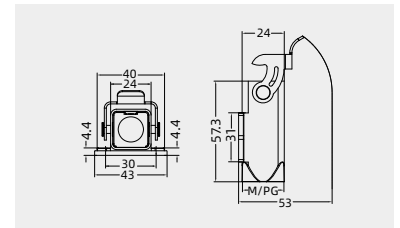

Housings, cable to cable



Thread	Designation	Order No.
M20	EMC.H3A-CCT-1L/W-M20	110 603 724 1002
PG11	EMC.H3A-CCT-1L/W-PG11	110 603 724 1008

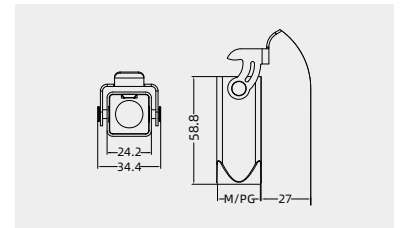



3A Metal hoods/housings

With sealing

Degree of protection: IP65

Protection covers



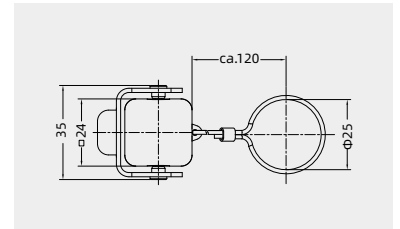

Connect way	Designation	Order No.
	H3A-MCV-1L/1M (for male insert)	110 003 024 8101
	H3A-MCV-1L/1F (for female insert)	110 003 024 8102



Protection covers



Connect way	Designation	Order No.
	H3A-MCV/S-2B/1	110 003 010 8103
	H3A-MCV/S-2B/2	110 003 010 8106

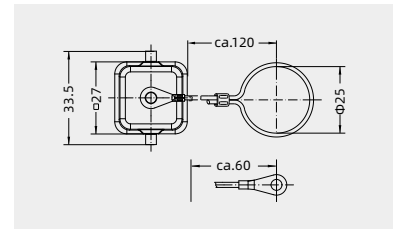

3A Pressure tight hoods/housings

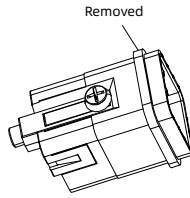

Note: Before installation, if there is a square seal ring on the used insert, the seal ring shall be removed before installation. For more details, please contact us.

Epoxy power paint
Degree of protection: IP68

H version

Hoods, top entry



Thread	Designation	Order No.
	Epoxy power paint · Screw locking	
M20	HP3A/H-TE-2S-M20	113 003 420 1002
PG13.5	HP3A/H-TE-2S-PG13.5	113 003 420 1009
	Epoxy power paint · Toggle locking	
M20	HP3A/H-TE-2T-M20	113 003 440 1002
PG13.5	HP3A/H-TE-2T-PG13.5	113 003 440 1009

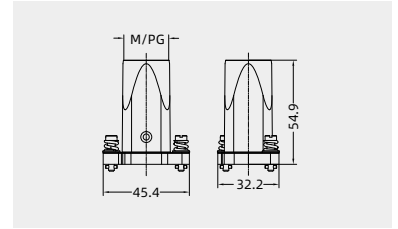

Bulkhead mounted housings



Thread	Designation	Order No.
	Epoxy power paint · Screw locking	
---	HP3A/H-BK-2H	113 003 320 1001
	Epoxy power paint · Toggle locking	
---	HP3A/H-BK-2T	113 003 340 1001

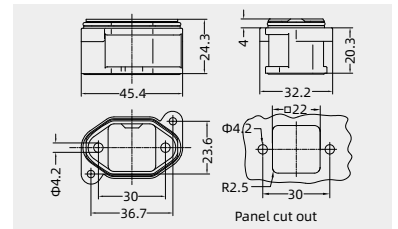

Adaptor for Housings*



Thread	Designation	Order No.
	Epoxy power paint	
---	HP3A/H-BK-SE	113 003 900 1001

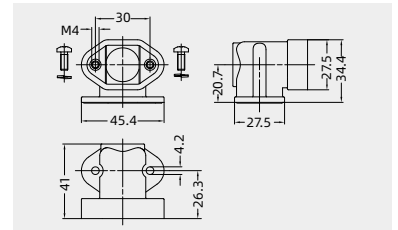

Surface mounted housings



Thread	Designation	Order No.
	Epoxy power paint · Screw locking	
M20	HP3A/H-SF-2H-M20	113 003 220 1002
PG13.5	HP3A/H-SF-2H-PG13.5	113 003 220 1009

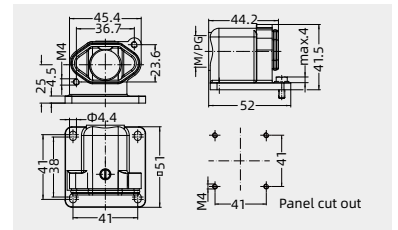

Bulkhead mounted housings



Thread	Designation	Order No.
	Epoxy power paint · Screw locking	
---	HP3A/H-SF-2H	113 003 220 1001

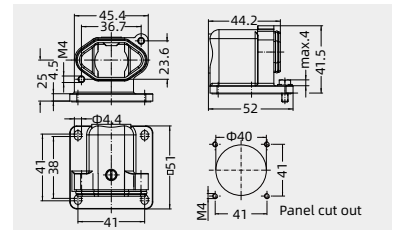

3A Pressure tight hoods/housings

Epoxy power paint

Degree of protection: IP68

Hoods, top entry, high construction



Thread	Designation	Order No.
	Epoxy power paint · Screw locking	
M25	HP3A/H-TEH-2S-M25	113 003 420 5003
	Epoxy power paint · Toggle locking	
M25	HP3A/H-TEH-2T-M25	113 003 440 5003

H version

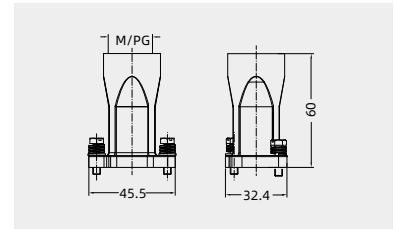

Protection covers



Connect way	Designation	Order No.
	Epoxy power paint · Screw locking	
---	HP3A/H-MCV-2S	113 003 020 8103
	HP3A/H-MCV-2S/2S	113 003 020 8102
	Epoxy power paint · Toggle locking	
---	HP3A/H-MCV-2T	113 003 040 8103
	HP3A/H-MCV-2T/2S	113 003 040 8102

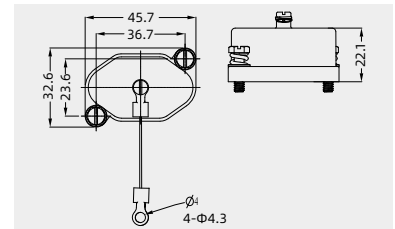

Degree of protection: IP68

Hoods, top entry



Thread	Designation	Order No.
M20	HP3A-TE-2S-M20	115 003 420 1002
PG11	HP3A-TE-2S-PG11	115 003 420 1008

W version

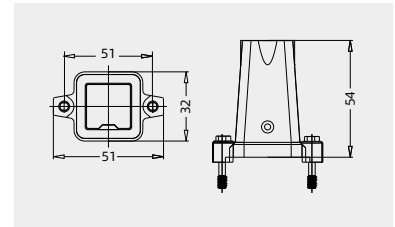

Housings, bulkhead mounting



Connect way	Designation	Order No.
---	HP3A-BK-2H	115 003 320 1001

